



## ASX ANNOUNCEMENT

7 April 2025

### Investor Presentation

Volt Group Limited (VPR or the Company) is pleased to provide an update on its operations and business units in the attached Investor Presentation.

---

**Issued by:** Volt Group Limited (ACN 009 423 189)

**Authorised by:** The Board of Volt Group Limited

**ASX CODE:** VPR

#### BOARD

**Adam Boyd**  
Executive Chairman

**Paul Everingham**  
Non-Executive Director

**Peter Torre**  
Non-Executive Director

**Simon Higgins**  
Non-Executive Director

#### ISSUED CAPITAL

10,717M Ordinary Shares  
430M Unlisted Options

#### PRINCIPAL OFFICE

6 Bradford Street  
Kewdale WA 6105

#### REGISTERED OFFICE

6 Bradford Street,  
Kewdale WA 6105

#### CONTACT

**Mr Adam Boyd**  
Executive Chairman

**P:** + 61 8 9350 6880

**M:** +61 439 888 103

**E:** [info@voltgroup.com.au](mailto:info@voltgroup.com.au)

[www.voltgroup.com.au](http://www.voltgroup.com.au)

## About Volt

**Volt Group Limited (ASX: VPR)** is an industrial technology company that develops and commercializes ESG focused, zero emission power generation and hydrogen production technologies and next generation auxiliary mining equipment.

The Company's businesses develop and commercialise innovative proprietary OEM equipment delivering "step change" client productivity & cost benefits and reduce scope 1 emissions.

## Business Activity Summary

The activities of our businesses include:

- **ATEN (100%)** – ATEN is a zero-emission waste heat to electricity generation equipment solution. The ATEN is at an advanced stage of initial commercialisation. ATEN enjoys Australian Innovation Patent certification. Refer below.
- **HYTEN (100%)** – HYTEN (patent pending) is a zero-emission waste heat to hydrogen solution developed to capture and exploit industrial waste heat (including gas turbine exhaust heat usually vented to atmosphere) and produce low cost, zero emission hydrogen fuel gas. HYTEN comprises the ATEN Waste Heat to Power system integrated with either an alkaline, PEM or solid oxide electrolyser to produce the hydrogen.
- **Wescone (100%)** – the proprietary owner of the globally unique Wescone W300 sample crusher predominantly deployed throughout the global iron ore sector. Wescone has a successful 25+ year operating track record and recently developed a new crusher with larger dimensional acceptance, reduction ratio and durability specifications.
- **EcoQuip (100%)** – developer and owner of a 'best in class' Mobile Solar Lighting & Communications Tower equipment solution incorporating robust design attributes including US military spec design & build quality, solar / lithium (LFP) battery storage solution and an advanced power management, data telemetry & control system. EcoQuip solutions are capable of zero emission, high performance mobile illumination, LTE, Wi-Fi mesh and point to point microwave network reinforcement and environmental monitoring and surveillance.
- **Acquisition / Development Strategy** – The Company actively pursues opportunities to expand its broader zero emission power generation and contract services capability, high yield infrastructure asset footprint & innovative equipment solutions.

**About the ATEN Technology:** The ATEN comprises a modular, power generation equipment package capable of harvesting 'low' grade industrial waste heat to generate zero emission baseload electricity.

ATEN generated electricity is expected to significantly reduce 'energy intensive' industry operating costs via the displacement of grid sourced electricity or fossil fuel usage associated with electricity generation. The global industrial complex vents a significant quantity of 'low' grade waste heat to atmosphere. This quantity of unexploited waste heat presents an outstanding opportunity for the commercial roll-out of ATEN.

The ATEN's simple, high efficiency design and modular configuration - developed to maximise its integration capability - provides a low capex, uniquely compatible and scalable solution for the exploitation of 'low grade' industrial waste heat from existing multiple sources. Volt's priority target markets for the commercialization of the ATEN Technology include the resources and industrial processing sectors.

The salient ATEN Waste Heat to Power technology benefits that resonate with power station owners include:

- Baseload, zero emission incremental power generation (Scope 1 Emission reduction) compatible with Solar Hybrid systems with high penetration;
- Levelised Cost of Electricity (LCOE)<sup>1</sup> up to ~50% lower than gas and ~80% lower than diesel generation;
- LCOE<sup>1</sup> ~50% lower than an equivalent annual generation Solar/Battery Energy Storage System (BESS);
- CAPEX ~60% lower than Solar / BESS based on identical annual generation and zero emission performance;
- Hydrogen co-firing compatibility.
- Safeguard Mechanism Credit legislation eligibility; and
- Zero water & operational personnel requirements

The ATEN system is eligible for Safeguard Mechanism Credits (SMCs) in certain circumstances pursuant to Australia's new Safeguard Mechanism legislation designed to reduce greenhouse gas emissions at Australia's large industrial, resource and energy sector asset fleet.

**1 Levelised Cost of Energy (LCOE) is based on new ATEN zero emission capacity and operating costs and variable costs of fuelled generation (where relevant) in the WA Pilbara region and the ARENA LCOE calculation methodology @ 8% discount rate and 20-year project life including SMCs (\$25/SMC) and Solar RECs (\$40/REC) as applicable.**

**2 Levelised Cost of Hydrogen (LCOH) is based on the LCOE methodology above inclusive of OEM supplier & EPC installation estimates of the capital and operating costs of hydrogen production via alkaline water electrolysis in the WA Pilbara region.**

For personal use only

ersonal use only

# VOLTGROUP

ASX:VPR

## Investor Presentation

6 April 2025

# Disclaimer

## Important notices and competent person's statement

This document is for informational purposes only. This document does not constitute or contain an offer, invitation, solicitation or recommendation with respect to the purchase or sale of any security in Volt. This document is not a prospectus, product disclosure statement or other offering document under Australian law or any other law, will not be lodged with the Australian Securities and Investments Commission, and may not be relied upon by any person in connection with an offer or sale of Volt securities.

### Summary information

This document contains a summary of information about Volt and its activities that, unless otherwise stated, is current as at the date of this document. The information in this document is general in nature and does not contain all the information which a prospective investor may require in evaluating a possible investment in Volt or that would be required in a prospectus or a product disclosure statement prepared in accordance with the Corporations Act or the securities laws of any other jurisdiction.

### No liability

The information contained in this document has been prepared in good faith by Volt, however no guarantee, representation or warranty expressed or implied is or will be made by any person (including Volt and its affiliates and their directors, officers, employees, associates, advisers and agents) as to the accuracy, reliability, correctness, completeness or adequacy of any statements, estimates, options, conclusions or other information contained in this document. No person other than Volt is responsible for the preparation of this document.

To the maximum extent permitted by law, Volt and its affiliates and their directors, officers employees, associates, advisers and agents each expressly disclaims any and all liability, including, without limitation, any liability arising out of fault or negligence, for any loss arising from the use of or reliance on information contained in this document including representations or warranties or in relation to the accuracy or completeness of the information, statements, opinions, forecasts, reports or other matters, express or implied, contained in, arising out of or derived from, or for omissions from, this document including, without limitation, any financial information, any estimates or projections and any other financial information derived therefrom.

Statements in this document are made only as of the date of this document unless otherwise stated and the information in this document remains subject to change without notice. No responsibility or liability is assumed by Volt or any of its affiliates for updating any information in this document or to inform any recipient of any new or more accurate information or any errors or mis-descriptions of which Volt and any of its affiliates or advisers may become aware.

### Forward looking statements

Certain information in this document refers to the intentions of Volt, but these are not intended to be forecasts, forward looking statements or statements about the future matters for the purposes of the Corporations Act or any other applicable law. The occurrence of the events in the future are subject to risk, uncertainties and other actions that may cause Volt's actual results, performance or achievements to differ from those referred to in this document. Accordingly Volt and its affiliates and their directors, officers, employees and agents do not give any assurance or guarantee that the occurrence of these events referred to in the document will actually occur as contemplated.

Statements contained in this document, including but not limited to those regarding the possible or assumed future costs, performance, dividends, returns, revenue, exchange rates, potential growth of Volt, industry growth or other projections and any estimated company earnings are forward looking statements. Forward-looking statements can generally be identified by the use of words such as 'project', 'foresee', 'plan', 'expect', 'aim', 'intend', 'anticipate', 'believe', 'estimate', 'may', 'should', 'will' or similar expressions. These statements relate to future events and expectations and as such involve known and unknown risks and significant uncertainties, many of which are outside the control of Volt. Actual results, performance, actions and developments of Volt may differ materially from those expressed or implied by the forward-looking statements in this document.

Such forward-looking statements speak only as of the date of this document. There can be no assurance that actual outcomes will not differ materially from these statements. To the maximum extent permitted by law, Volt and any of its affiliates and their directors, officers, employees, agents, associates and advisers:

- disclaim any obligations or undertaking to release any updates or revisions to the information to reflect any change in expectations or assumptions;
- do not make any representation or warranty, express or implied, as to the accuracy, reliability or completeness of the information in this document, or likelihood of fulfilment of any forward-looking statement or any event or results expressed or implied in any forward-looking statement; and
- disclaim all responsibility and liability for these forward-looking statements (including, without limitation, liability for negligence).

### Not financial product advice

This document does not constitute financial product advice or take into account your investment objectives, taxation situation, financial situation or needs. This document consists purely of factual information and does not involve or imply a recommendation of a statement of opinion in respect of whether to buy, sell or hold a financial product.

An investment in Volt is considered to be speculative in nature. Before making any investment decision in connection with any acquisition of securities, investors should consult their own legal, tax and/or financial advisers in relation to the information in, and action taken on the basis of, this document.

### Acceptance

Each recipient of this document is deemed to have accepted the qualifications, limitations and disclaimers contained herein.

# Corporate & Management

## Capital Structure

|                                      |         |
|--------------------------------------|---------|
| <b>Shares on issue</b>               | 10,717M |
| <b>Options on issue</b>              | 430M    |
| <b>Market Cap</b> (@ \$0.0015/Share) | \$16.1M |
| <b>Cash</b> (at 31 March 2025)       | \$1.8M  |
| <b>Debt</b> (at 31 March 2025)       | \$0.2M  |
| <b>Enterprise Value</b>              | \$14.5M |

## Board



**MR ADAM  
BOYD**  
Executive Chairman



**MR PAUL  
EVERINGHAM**  
Non-Executive Director



**MR PETER  
TORRE**  
Non-Executive Director



**MR SIMON  
HIGGINS**  
Non-Executive Director

## Management



**DAVE  
SHARP**  
GM, EcoQuip



**ADELA  
CIUPRYK**  
Chief Financial Officer

# FY24 Financial Highlights

## Revenue

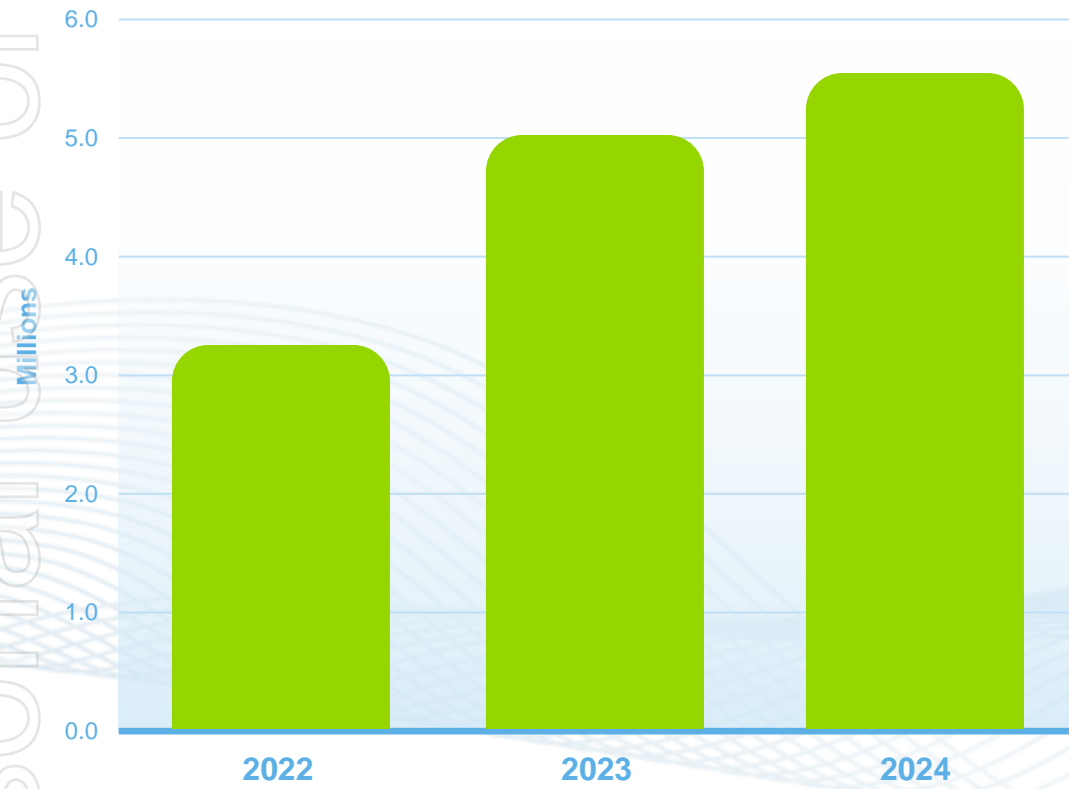

## EBITDA

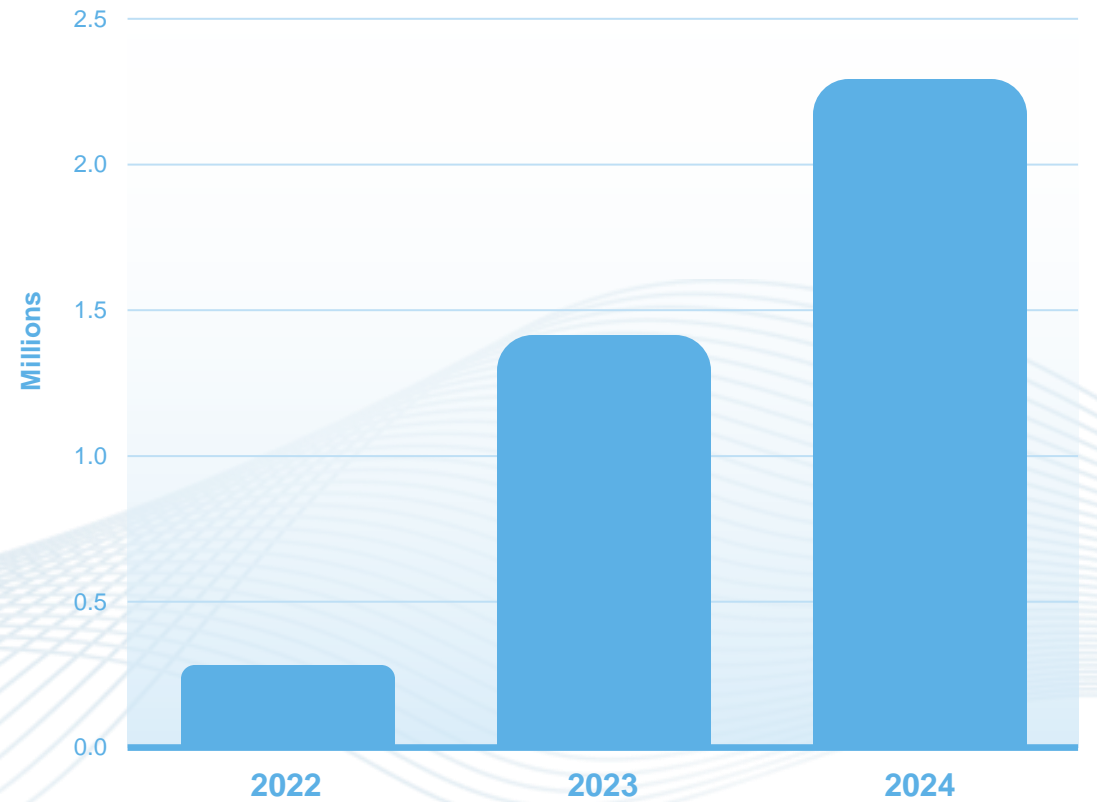

# Business Overview

Volt Group Limited (ASX: VPR)

“An industrial technology OEM developing next-generation mining equipment solutions and ESG focused, zero emission energy technologies that reduce costs with scalable growth potential across global markets”

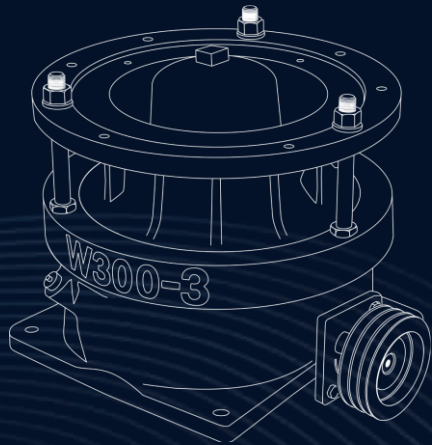

**WESCONE**

The Resource Sector Sample  
Crushers Benchmark

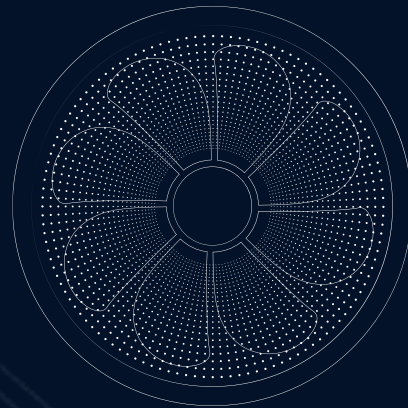

**ATEN**

Lowest Cost, Zero Emission  
Baseload Power

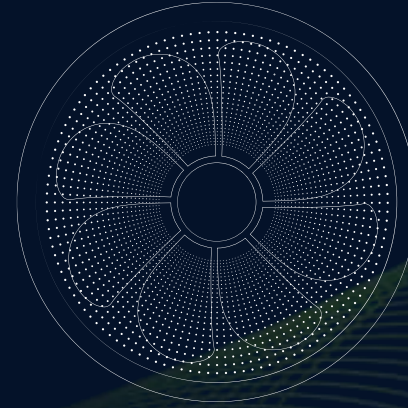

**HYTEN**

Lowest Cost, Zero Emission  
Hydrogen

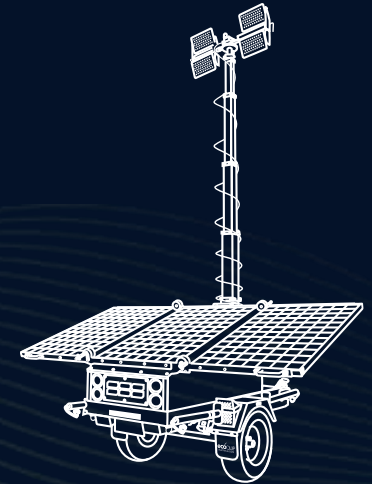

**ecoQUIP**

Mobile Solar Light &  
Communications Towers

# ECOQUIP

## Zero Emission Mobile Light & Comms Tower

~50% cheaper than traditional diesel solutions

**VOLT**GROUP

ecoQUIP

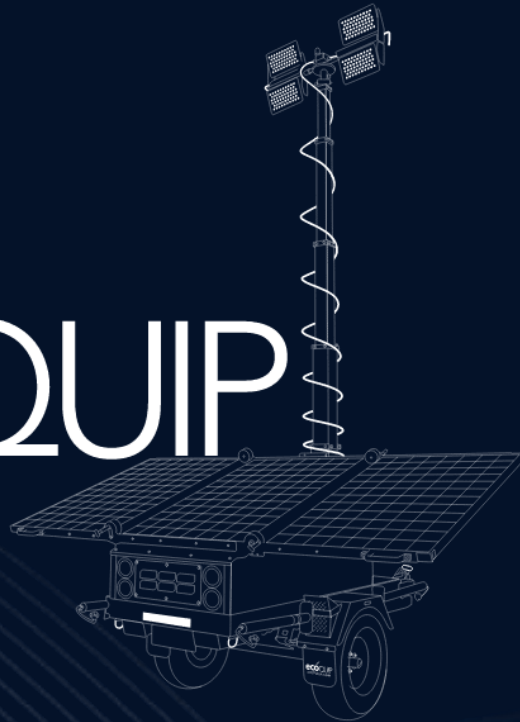

**EcoQuip** OEM solutions (patent pending) deliver:

- Market-leading illumination performance
- ~50% cost savings vs trad diesel light plant
- Military-spec build quality & high reliability
- Technology Platform that delivers real-time telemetry, remote control, data analytics and pre-emptive Ai performance notifications

**EcoQuip light & communication solutions are scalable with growth opportunities across global markets and industries.**

ersonal use only

# ECOQUIP

## Technology Platform & Equipment Solutions

**VOLT**GROUP

The EcoQuip Technology Platform developed with US domiciled aerospace electronics, power management, software and illumination experts

Breaks new ground on charge / performance efficiency, illumination footprint & active / predictive Ai software capabilities

The autonomous platform is deployed in four EcoQuip solutions:

1. **Mobile Solar Light Tower** – power budget & illumination performance to displace diesel fuel traditional solutions
2. **Mobile Solar Communications Tower** – power budget to support ‘mission critical’ autonomous mining network reinforcement
3. **Mobile Solar Environmental Tower** – remote camera surveillance, movement & noise monitoring / telemetry
4. **Mobile Remote Surveillance Tower** – remote Ai camera live satellite surveillance

# High Performance No Compromise



# ECOQUIP

## Capabilities for the 'Mines of the Future'

**VOLT**GROUP

### Customer Cloud Portal

Real-time, cloud-based data telemetry reporting via web-enabled client portal with remote-control capability via Wi-Fi, 4G & Satellite

### Proprietary Solar / BESS Energy storage system

22KWh BESS – Lithium Ferro Phosphate

### High Performance Luminaires

Uniquely developed OEM 'high efficiency' illumination technology to optimise work area lux footprint

### Military-Grade Fab & Coatings

Built to US military specification quality

### Proprietary Power Management Controller

~40% enhanced efficiency with multiple diagnostic & notification capabilities and remote notifications

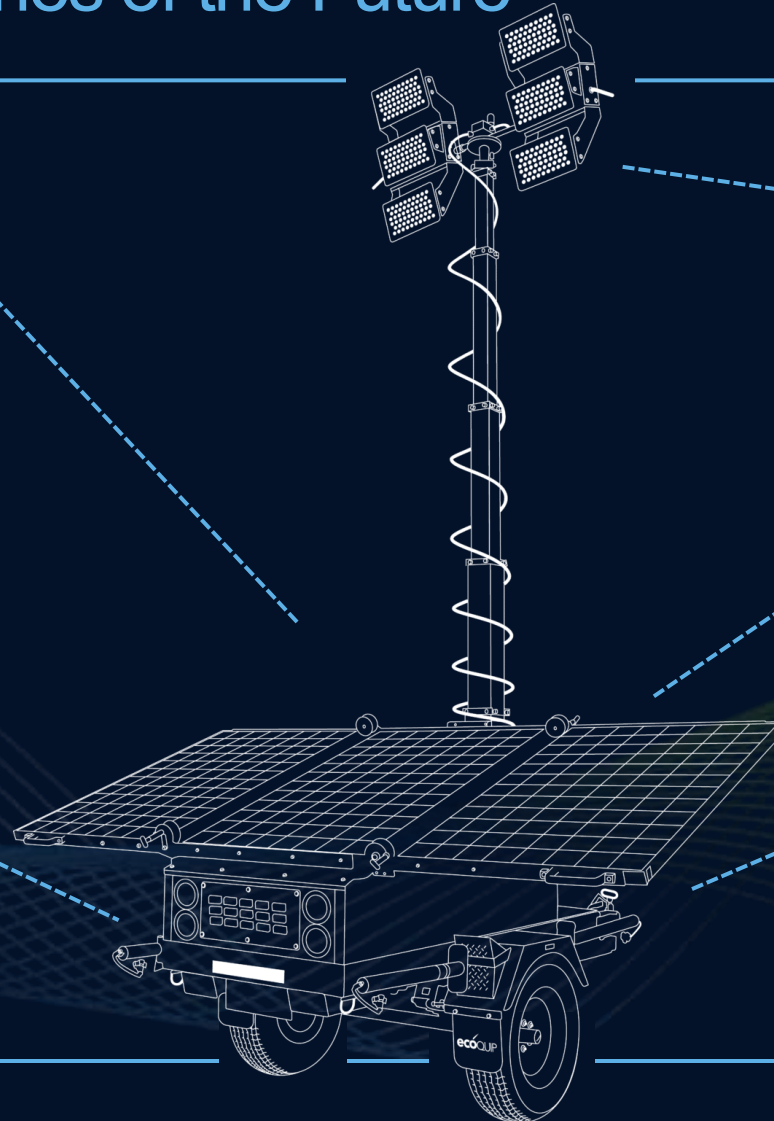

ersonal use only

# ECOQUIP

## Market Opportunity

### Large Total Addressable Market in WA/Pilbara & USA market

- **EcoQuip** has ~80 units deployed across Chevron, Thiess, BHP, Macmahon, Westgold and growing
- **EcoQuip** run-rate revenue today of ~\$2.3m per annum
- Pilbara market ~3,000<sup>1</sup> light towers - \$80m p.a. revenue potential
- Large addressable market in Australia across resources, construction / infrastructure and defence applications
- Significant market opportunity in the southern states of USA
- USA light tower market estimated at \$1.5B<sup>2</sup>

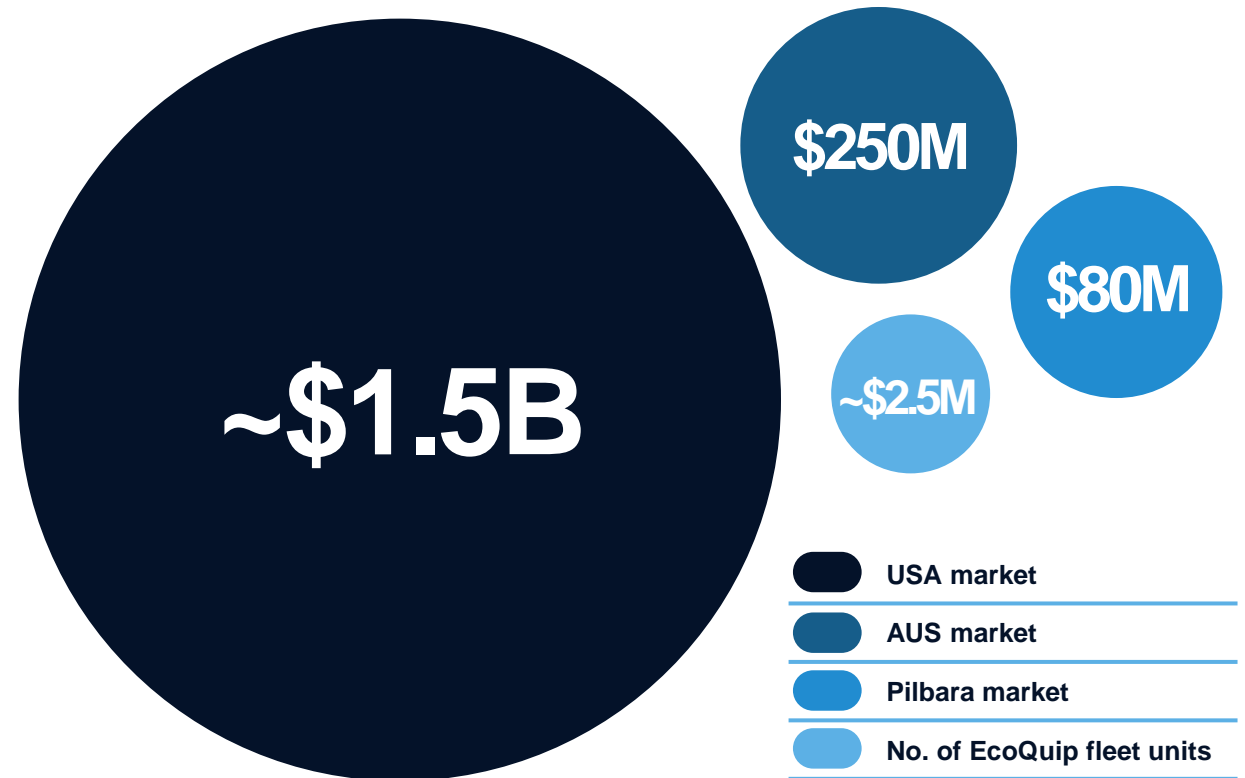

<sup>1</sup> EcoQuip management estimate

<sup>2</sup> Light Tower research report by [www.researchandmarkets.com](http://www.researchandmarkets.com)

# ECOQUIP Case Study

## Barrow Island Deployment

**VOLT**GROUP

Average MSLT #  
Deployed

**50**

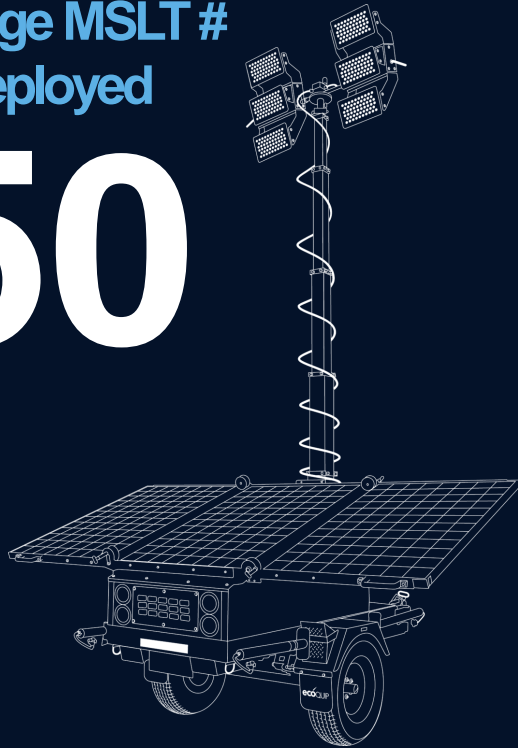

Average Time On Per Day



**10**  
Hours

Deployment Period

**~3 years**

Total Diesel Saved

**1,056,000** Litres

Total CO<sub>2</sub> Abated

**~3,200** Tonnes

Net Total Cost Saved Vs Diesel (\$A)

**3,750,000**

*A fantastic result... we all love the solar towers both from an environmental perspective and utility perspective. They are so useful, easy to use and the options / control we have over them with the dashboard, timing and other settings is just fantastic.*

# ECOQUIP

## Australian & USA Market Developments

**VOLT**GROUP

Record \$2.0m FY24 revenue (\$1.2m FY23) results

Total 55x MSLT fleet deployed at Barrow Island – displaced 100% operational trad. diesel fueled lighting plant

Completed manufacture and deployment of 20 new Mobile Solar Light Towers (MSLTs) at Chevron's Gorgon project

Signed 'evergreen' Plant Hire Contract with Thiess, the world's largest contract miner

Advanced manufacture of additional 30 MSLTs for completion in April / May 2025

Advanced demonstration trials BHPIO, Westgold, Thiess and MacMahon operational sites

Initiated USA presence with 8x MSLT demonstration units at Chevron's West Texas operations

Ongoing R&D Programs to deliver enhanced illumination, higher efficiency & capital cost reduction

ersonal use only

# WESCONE

## Value Proposition

**VOLT**GROUP

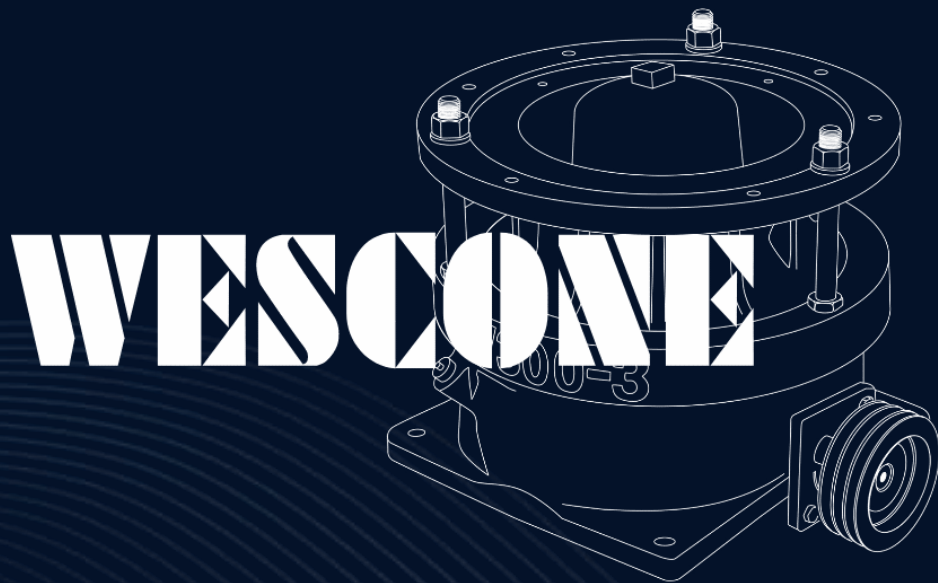

**Wescone** OEM Sample Crusher solutions (patented) deliver:

- market leading single pass high through put performance – 6tph (15:1 reduction)
- Maximum reduction ratio up to 25:1
- Long lifecycle duration
- Robust build quality

A 25+year history integrated into iron ore sector ISO3082-accredited sample systems. Wescone crushers have an established market presence and global growth opportunities.

# WESCONE

## The Product

**VOLT**GROUP

- **Wescone** manufactures the proprietary W300 sample crusher range and sample crushing solutions for the mining, mineral processing and assay laboratory industries.
- The **Wescone** W300 range comprises three alternative sample crushers with unique dimensional feed acceptance capabilities.
- **Wescone** has a 25-year track record of supplying the global iron ore industry as an embedded component of ISO3082 accredited sample systems
- **Wescone** sales total 300 x W300 crushers across three continents

**BHP**



GLENCORE



RioTinto



# WESCONE

## Australian & African Market Developments

**VOLT**GROUP

- Successful R&D program to extend lifecycle performance of Wescone W300 completed in 2024 - continuous improvement

- Received positive feedback from largest customers, BHP and Rio Tinto

- Secured new African distribution partner, Mineral Innovative Technologies (MIT)

- MIT brings 10-year track record in sample preparation equipment and laboratory systems

- Expanded customer base continues to include leading mining companies: BHP, BHP Nickel West, Anglo American, Roy Hill, Fortescue, Assmang, Rio Tinto and Glencore

- Supplied to new Rio Tinto & BHP projects during 2023 - 2025 (Gudai Darri, Cape Lambert Lab, South Flank, Western Ridge)

- 8x new crushers supplied to Anglo American SA located iron ore mines in 2024

- New W300 prototype deployed in the Pilbara with higher moisture feed specification capability – ore mining encountering water table / dust suppression water

ersonal use only

# ATEN Waste Heat to Power

PowerGen efficiency, affordability & hybrid network stability

**VOLT**GROUP



# ATEN

The **ATEN System** recovers exhaust waste heat energy from existing open cycle gas turbine power stations to generate incremental, zero-emission, baseload power.

**ATEN** complements renewable hybrid / gas fueled networks via significantly lower cost, enhanced network stability and reduced carbon intensity Vs solar/wind/BESS alone.

**ATEN** drives energy efficiency to reduce gas consumption and carbon intensity of gas fueled power generation by 15 – 30% (enhanced efficiency).

The energy efficiency pathway to lowest cost, zero emission baseload power.

# ATEN

## Proven OEM sub-systems

**VOLT**GROUP

### ATEN (Accretive Thermal Efficiency Node)

“a unique combination of proven energy recovery sub-systems in a patented configuration”

- Baseload, zero emission incremental electricity for a ~60% lower CAPEX and ~50% lower lifecycle cost Vs annual generation equiv. solar and wind.
- ~15 - 30% capacity and generation increase with zero additional fuel gas use.
- Compatible existing solar / wind / gas hybrid systems connected to remote off-grid and on-grid electricity networks.
- Enhances OCGT energy efficiency - critical to supporting the Renewables Roll-out and mission critical industrial process emission reduction.



ersonal use only



# ATEN

## The ATEN Value Proposition (A\$ LCOE comparison)

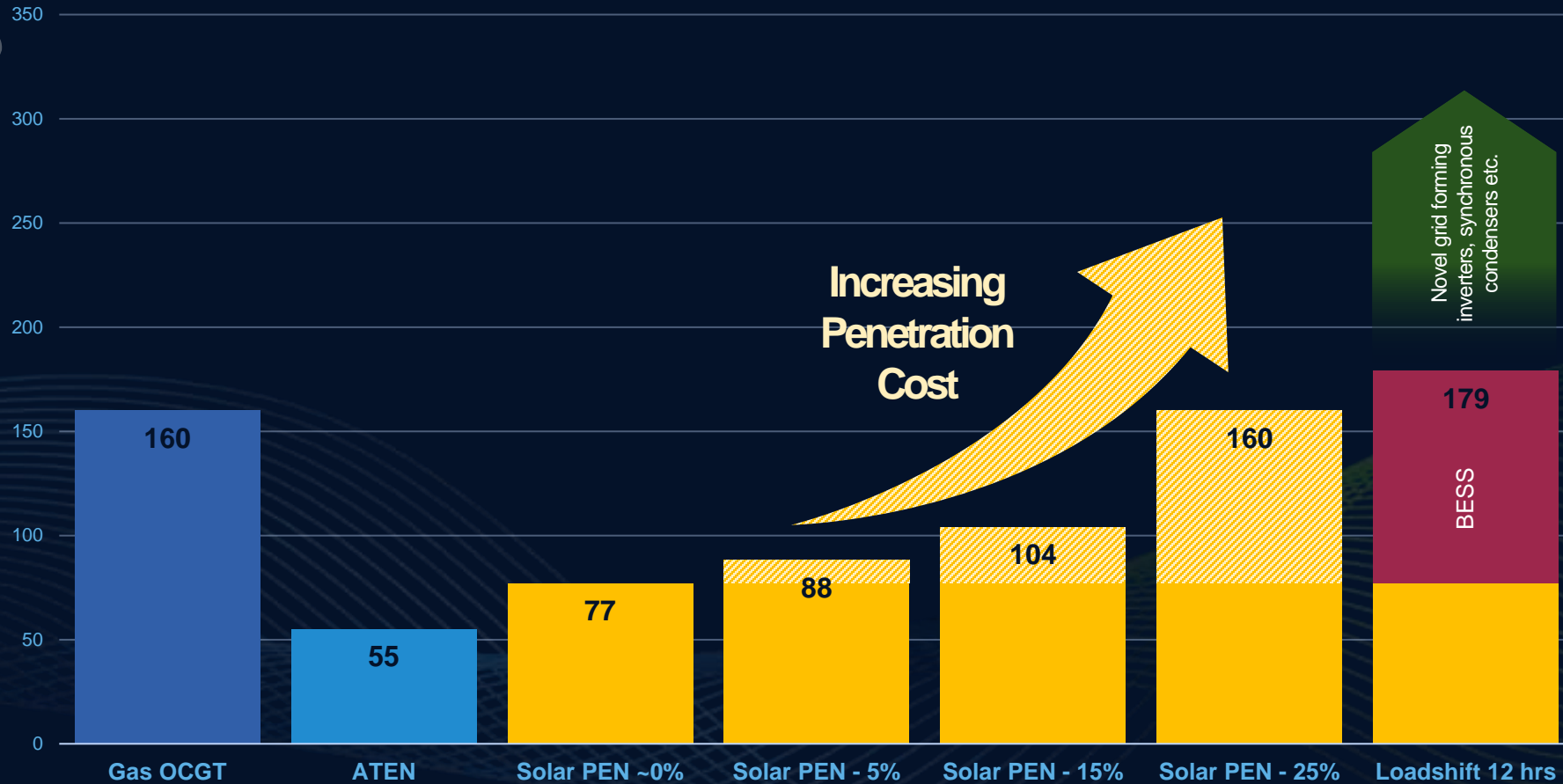

1. OCGT LCOE - GE LM6000 @ A\$9/GJ for fuel gas
2. ATEN LCOE - ~A\$4.4M/MW CAPEX - 2022 Pre-feasibility Study (inc. Remote Install CAPEX Adj +30%), Utilisation 95% (Baseload)
3. Solar LCOE - A\$2.5M/MW(AC) CAPEX - 2021 IRENA Solar Generation (inc. Remote Install CAPEX Adj +30%); Utilisation - 28.5% (Intermit.)
4. BESS CAPEX - ~A\$0.58M/MWh - 2023 CSIRO Gen Cost Study
5. Solar System Integration LCOE for 5%, 15% & 25% Penetration - 2023 Rystad Energy, Asian Region Energy Security, ANGEA Study
6. LoadShift 12hrs LCOE - Solar & 12xMWh BESS CAPEX per Notes 3 & 4 above. 88% Round Trip Efficiency
7. ARENA LCOE calc method @10% disc rate
8. Legislated Subsidies - A\$30/SMC & A\$40/REC
9. Network connection & ancillary services CAPEX excluded
10. A\$ ; US\$ FX - 0.68

ersonal use only

# ATEN

## Australian Market Developments

Completed ATEN Concept Study for retrofit on an existing OCGT Power Station WA Government-owned GenTailer, Synergy

Concept Study demonstrated significant benefits for existing gas power stations:

- 20MW additional power capacity (~15% increase)
- Carbon intensity reduction of 82,800t CO<sub>2</sub> per annum
- Net financial benefit of ~A\$21 million per annum
- CAPEX of ~A\$85 million with 4-year payback
- LCOE of 7.6c/kWh and marginal cost of 2.5c/kWh

Australian Federal Government's 'Future Gas Strategy' supports ATEN's market positioning

ATEN remains eligible for Safeguard Mechanism Credits under Australian legislation (off-grid)

Preparing ARENA "Industrial Transformation Stream" Full Application to 50% fund a Synergy ATEN Definitive Feasibility Study

Market Analysis (completed by CarbonTP) identified numerous 'high value' OCGT retrofit opportunities

# HYTEN Waste Heat to Hydrogen

## Lowest Cost, Zero Emission Hydrogen

**VOLT**GROUP



# HYTEN

The **HYTEN** technology (patent pending) is a proprietary waste heat to hydrogen system that combines:

- Volt's low-cost, zero emission ATEN waste heat to power technology; and
- either solid oxide, PEM or alkaline water electrolyser sub-systems

**Low-cost, transitional technology pathway to produce zero emission hydrogen @ LCOH<sup>2</sup> of \$US2.50 – 4 / kg no subsidy.**

<sup>2</sup> Levelised Cost of Hydrogen (LCOH) is based on the LCOE methodology at footnote 1 inclusive of OEM supplier & EPC installation estimates of the capital and operating costs of hydrogen production via alkaline water electrolysis in the WA Pilbara region

## THE HYTEN SYSTEM

The **HYTEN** System design comprises three proven and well established primary sub-system solutions:

1. The **ATEN** waste heat recovery and thermal oil sub-system (Waste Heat Recovery Package); and
2. The **ATEN** organic rankine cycle and power generation sub-system including modular air-cooled or water-cooled condenser (ORC Package); and
3. An alkaline water electrolyser and hydrogen separation system (Electrolyser Package).

## FLWSHEET

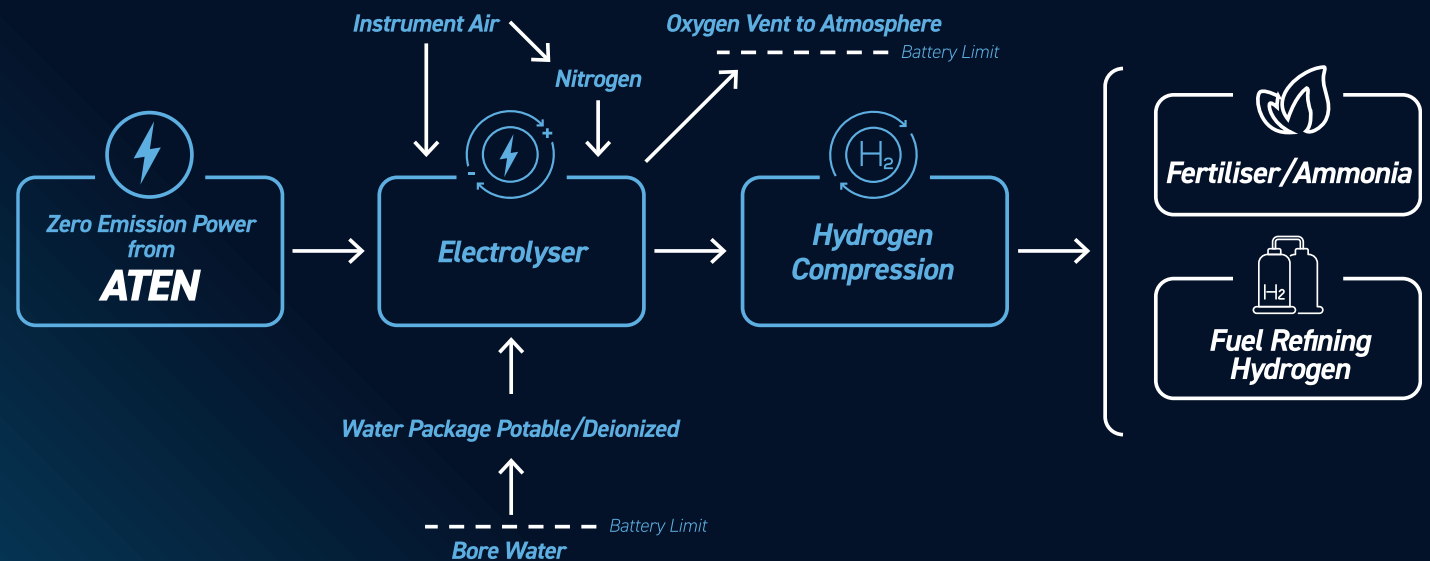

HYTEN has competitive advantages and the potential to produce zero emission hydrogen for a ~50% lower CAPEX and ~60 – 70% lower lifecycle cost compared to Solar & Wind Green Hydrogen systems.

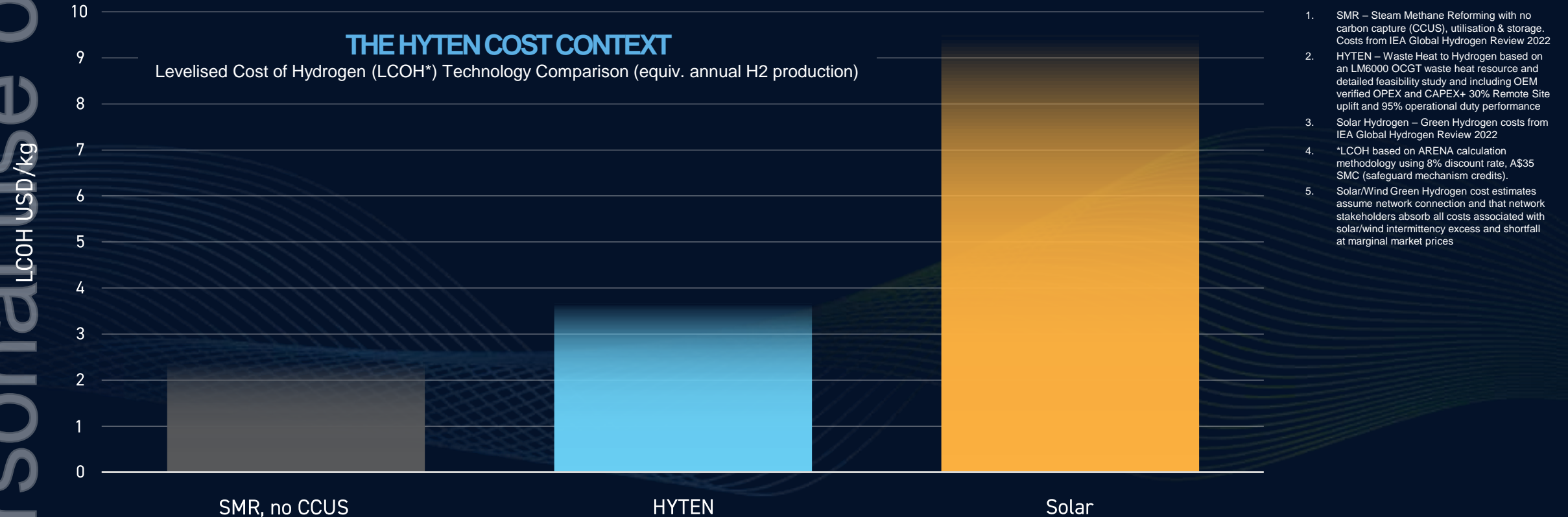

# Investment Case: Volt Power Group

The Right Products in the Right Industries, Right Now

**VOLT**GROUP

VOLT's OEM solutions are Proven, Practical, and Reliable new products and technologies delivering cost savings and Net Zero transition solutions. Government and the resources sector has an urgent need to reduce costs and emissions while improving productivity, reliability and security

innovate | create | deliver

ersonal use only

ersonal use only

# VOLTGROUP

ASX:VPR

[voltgroup.com.au](http://voltgroup.com.au)