

8 April 2025

## FINAL INVESTMENT DECISION DEFERRED FOR TUMAS PROJECT

*A staged development approach has been adopted, with engineering and early works continuing. Construction of the processing plant has been delayed until improved uranium price incentive supports greenfield project development.*

### HIGHLIGHTS

- **The Board of Deep Yellow has given approval for further staged development of the flagship Tumas Project, located in Namibia. The approval excludes the start of construction of the process plant, which will be determined subject to improved uranium pricing.**
- **Latest optimisation work generated robust results at a uranium price of US\$82.50/lb U<sub>3</sub>O<sub>8</sub>, further endorsing the Project's economics and standing as a Tier-1, long-life uranium operation:**
  - NPV post-tax: US\$577M (A\$912M);
  - IRR post-tax: 19%;
  - Initial CAPEX: US\$474M (A\$750M); and
  - C1 OPEX, first 20 years: US\$24.52/t ore treated, US\$35.02/lb U<sub>3</sub>O<sub>8</sub>.
- **Three-phase development approach to preserve shareholder value and further derisk future full development:**
  - ongoing detailed engineering to ensure the project is “shovel ready” to enable a low-risk, fast response to anticipated uranium price turnaround, with further refinement of execution schedule, mining schedule, OPEX and CAPEX through continued detail design work;
  - ongoing investment in early works infrastructure, including water and power, maintaining project momentum and ensuring key inputs will be available when required; and
  - full-scale process plant construction to be approved only when there is sufficient uranium price incentive for greenfield project development.
- **Project financing will continue to be advanced.**
- **Deep Yellow remains in a strong financial position with a group cash balance of A\$227 million (at 31 March 2025). A group cash balance of A\$170-180 million is expected at 31 December 2025, after anticipated expenditure on early works infrastructure and the detailed engineering referred to above. This leaves the Company with a significant cash buffer for moving forward.**

For personal use only

Deep Yellow Limited (**Deep Yellow** or the **Company**) is pleased to provide an update regarding its flagship Tumas Project (**Tumas** or the **Project**) and its progress toward a positive Final Investment Decision (**FID**) following the completion of the latest engineering and optimisation work.

The additional detailed engineering carried out in the past three months has confirmed Tumas as a robust, long-life project. However, as previously stated, the key element to delivering FID was always going to be the prevailing uranium market conditions that would justify development of a greenfield uranium project. Therefore, FID has been deferred in order to fully capitalise on the Project's upside potential and thereby protect shareholder value.

The Board has made the decision to provide staged approval for the project and is delaying construction of the processing plant which involves the majority of estimated capital expenditure. Deep Yellow will continue to move ahead with early works infrastructure development and detailed engineering, however full-scale project development will be delayed allowing for what the Board believes will be the inevitable improvements in global uranium prices due to increasing demand and the precarious nature of the supply outlook.

**Deep Yellow Managing Director Mr. John Borshoff commented:** *“We are at an extraordinary stage in the uranium supply sector. We have a situation where the long-term uranium market is essentially broken. This is due to more than a decade of sector inactivity, persistently depressed uranium prices, and utility offtake contracting practices which are yet to support the development of greenfields uranium production. Although the Tumas Project is economic at current long-term uranium prices, these prices do not reflect or support the enormous amount of production that needs to be brought online to meet expected demand. Also, we can expect from experience that supply shortages will only be exacerbated by likely delays and underperformance of the sector generally.*

*“Deep Yellow is in an enviable position having one of the most rigorously evaluated greenfield projects in the world ready to hit the “go” button. The extended detailed engineering and associated studies that have been completed provide even greater confidence of what can be delivered and how. Water and power supply agreements have been completed as we push ahead with the off-site infrastructure needs, and project financing is proceeding well. Combine this with the strong stewardship offered by our fully proven technical teams and leadership, unique to the sector of emerging producers, and it is clear we have all the ingredients and capability to move ahead positively when justified.*

*“The Tumas Project is ready to take the next step but, as we have consistently stated, a healthy prevailing uranium market is a key prerequisite. The final project approval will therefore be delayed until uranium prices fully reflect a sustainable incentivisation environment essential to encourage development of new projects for much needed additional production.*

*“This is a deliberate strategic decision reflecting the Company's experience-based approach to sustainable uranium production aimed entirely at preserving the Company's precious resources and reserves to achieve better value for Deep Yellow and its shareholders and facilitate continued growth. We believe our shareholders are patient and would prefer that we maximise value rather than rush to market. We will continue to derisk the project through a staged development approach.*

*“Our unwavering view of the global uranium market and the long-term supply/demand equation remains clear. The demand outlook is undeniable, driven by decarbonisation efforts, forecasts of continued enormous energy demand growth, the prevailing structural supply shortages and now having to deal with the added, newly emerging requirements from the developers of energy-hungry datacentres, give clear upside for the supply sector.*

*“The reality is there are limited greenfield uranium deposits available for start-up globally over the next 10 years to satisfy projected demand, and new uranium supply will be virtually impossible to achieve in the current price environment.*

*“Nuclear utilities cannot ignore the fact that unless uranium prices increase to appropriate levels and large amounts of capital become available to the supply sector, those greenfields projects will remain undeveloped.*

*“It is against this backdrop that we are comfortable with our decision to carefully progress areas of the project such as early works infrastructure and detailed engineering but not commit the capital to construct the process plant at this time.”*

## **Updated Ore Reserve Estimation (ORE)**

The Company announced an upgraded Ore Reserve base (ASX release 18 December 2024) for the Tumas Project. The Mineral Resource for all Tumas deposits (1, 1E, 2 and 3) now includes a substantial proportion in the Measured JORC category and has proved sufficient to achieve the first key milestone of the Updated ORE, which is to establish sufficient Ore Reserves to support a 30-year Life-of-Mine (**LOM**).

Cube Consulting Pty Ltd (**Cube**) was engaged by the Company to undertake the Ore Reserve update and has completed pit optimisation studies on the Measured and Indicated portions of the deposit, pit designs and pit production scheduling. This work has resulted in the reporting of an updated ORE for the Tumas project (December 2024).

This updated ORE includes Proved and Probable Ore Reserves of 79.3 Mlb  $U_3O_8$  at 298 ppm, using a 100 ppm  $U_3O_8$  cut-off and a \$100/lb uranium price for the Tumas deposits (refer Table 1), with an average waste to ore ratio of 2.2 to 1. The \$100/lb pit shell was chosen for the final pit design work due to the relative insensitivity of the pit economics to uranium prices above \$80/lb and the resulting ease of pit design. This substantial increase in Ore Reserves confirms that Tumas can support a 30-year LOM at production rates assumed for this 2025 DFS (a maximum of either 4.2 Mtpa ore processed or 3.6 Mlb  $U_3O_8$  produced pa).

**Table 1: Tumas Project Updated Ore Reserve Estimates by Deposit.**

	Ore Reserve			
	U <sub>3</sub> O <sub>8</sub> Cut-off ppm	Tonnes Mt	U <sub>3</sub> O <sub>8</sub> ppm	U <sub>3</sub> O <sub>8</sub> Metal Mlb
Tumas 3 Proved	100	21.0	357	16.6
Tumas 3 Probable	100	30.3	398	26.6
<b>Total</b>	<b>100</b>	<b>51.3</b>	<b>381</b>	<b>43.2</b>
Tumas 1 and 2 Proved	100	23.7	227	11.9
Tumas 1 and 2 Probable	100	10.1	238	5.4
<b>Total</b>	<b>100</b>	<b>33.8</b>	<b>230</b>	<b>17.8</b>
Tumas 1 East Proved				
Tumas 1 East Probable	100	35.0	246	19.0
<b>Total</b>	<b>100</b>	<b>35.0</b>	<b>246</b>	<b>19.0</b>
Total Proved	100	44.7	287	28.4
Total Probable	100	75.4	305	50.9
<b>Total</b>	<b>100</b>	<b>120.1</b>	<b>298</b>	<b>79.3</b>

The rounding in the above Table 1 is an attempt to represent levels of precision implied in the estimation process which may result in apparent errors of summation in some columns.

## Project Optimisation

In February 2023, the Company completed the Tumas Detailed Feasibility Study (**DFS**) and informed the market of the robust nature of the Tumas Project. Late in that year, a re-costing was completed to assess the impact of the post-Covid 19 project development environment. The findings of this work were incorporated into the DFS, resulting in the December 2023 Detailed Feasibility Re-Costing Study (**DFS Re-Costing**) which identified a more robust project. Since that time, the Company has undertaken infill drilling to establish Proved Reserves for the first 6 years of the operational phase of the Project and expand the Reserve inventory (as discussed above). It has also undertaken a detailed engineering phase and optimisation work. The results of all these work programs have been incorporated into the DFS to create an updated March 2025 Detailed Feasibility Study (**2025 DFS**). The 2025 DFS study results provide current project information and were a key input for consideration of a FID for Tumas.

**This announcement contains the Executive Summary from the 2025 DFS, which is included as Annexure A.**

For the 2025 DFS, foreign exchange rates (**FOREX**) used in the CAPEX and OPEX estimates were updated as presented in Table 2 below. The notable movement is between the USD and the ZAR and NAD.

**Table 2: FOREX Rates.**

Currency	Currency Name	2025 DFS	DFS Re-Costing
AUD	Australian Dollar	0.6324	0.680
EUR	Euro	1.0879	1.005
NAD	Namibian Dollars	0.0550	0.0535
USD	United States Dollar	1	1
ZAR	South African Rand	0.0550	0.0535

For personal use only

The studies and associated detailed engineering were undertaken as a collaborative effort by the Deep Yellow Owner's Team and Ausenco personnel and have been completed in accordance with Ausenco's costing standards to develop a project control cost estimate. Ausenco has consented to being associated with the 2025 DFS and its conclusions.

### Capital Cost Estimate

Value continues to be delivered from the 2025 DFS studies and the local infrastructure carried out. In the intervening 16-month period since the delivery of the DFS Re-Costing, the work completed has delivered further credibility to the Project. It identifies a modest increase in CAPEX that is within the previously stated accuracy limits of the DFS Re-Costing, while giving more confidence for FID consideration and project execution. In conjunction with the updated ORE, it continues the trend to an increasingly robust project with long life. CAPEX variances to the DFS Re-Costing are shown in Table 3 below and graphically in Figure 1. Contingency was reassessed in this capital cost estimate due to present global market volatility and will be reassessed after further engineering is completed.

**Table 3: Summary of Capital Cost Estimate Outcomes (US\$M)\*.**

Category	DFS Re-Costing	2025 DFS	Delta
1000 - Mining	13	14	1
2000 - Process Plant, Front End	158	191	32
2000 - Process Plant, Back End	58	93	35
4000 - Facilities	12	17	6
5000 - Off-Site Infrastructure	25	25	-
6000 - Temporary Construction Facilities and Services	18	18	-1
6600 - Spares and First Fills	20	13	-7
7100 - Project Delivery Services (EPCM Costs)	39	29	-9
8000 - Owner's Costs and Pre-Production	52	35	-17
9200 - Contingency	18	39	21
<b>Total</b>	<b>412</b>	<b>474</b>	<b>62</b>

\* May contain rounding errors.

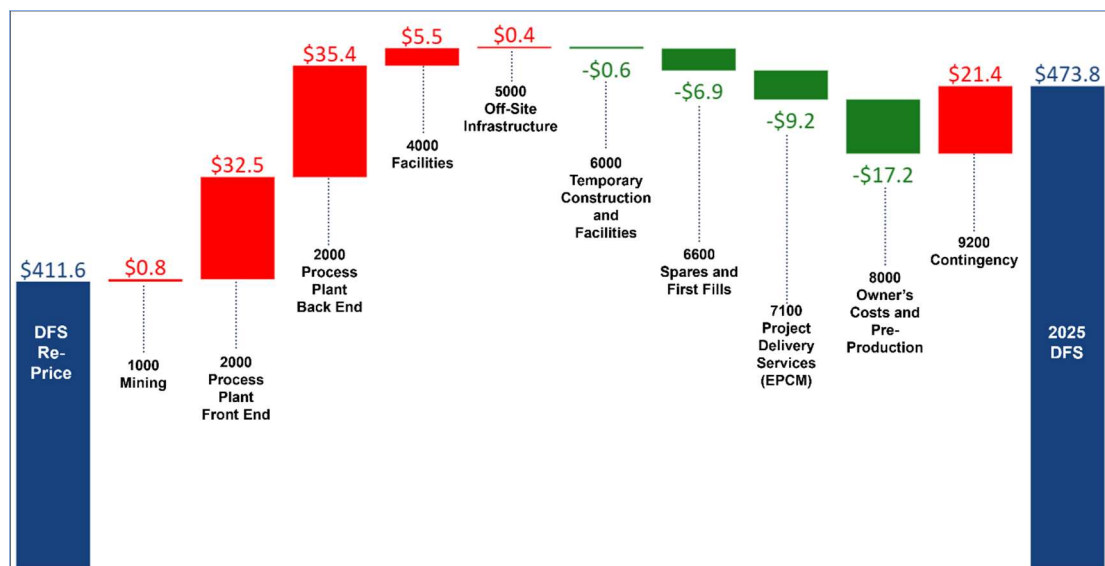

**Figure 1: CAPEX Variances to the DFS Re-Costing.**

For personal use only

## Operating Cost Estimate

As part of the 2025 DFS, a complete operating cost estimation was also undertaken. The utilities, reagents, consumables, and salaries and wages costs provided positive and negative price variation from that shown in the DFS Re-Costing (Table 4), resulting in a LOM net C1 cost decrease of US\$1.28/t of Run of Mine (**ROM**) feed, going from \$25.69/t to \$24.40/t (before vanadium offset).

However, due to the expanded Reserve inventory being of lower average grade than for the DFS Re-Costing (340 ppm U<sub>3</sub>O<sub>8</sub> vs 298 ppm). The C1 cost per lb U<sub>3</sub>O<sub>8</sub> increased from US\$34.35/lb U<sub>3</sub>O<sub>8</sub> to US\$38.60/lb U<sub>3</sub>O<sub>8</sub>. The mining schedule will be reassessed in the next phase to reduce this impact of average head grade and cost per lb U<sub>3</sub>O<sub>8</sub> produced.

Table 4 provides a summary of the top 8 OPEX variable cost contributors in US\$/t of ROM ore.

**Table 4: Top 8 Variable Cost Contributors and Delta.**

Description	DFS Re-Costing	2025 DFS	Delta	
	(\$/t ROM)	(\$/t ROM)	(\$/t ROM)	%
CaO (Lime)	0.56	0.30	(0.26)	(46.0%)
Flocculant	0.37	0.39	0.02	6.8%
Na <sub>2</sub> CO <sub>3</sub>	1.15	0.89	(0.27)	(23.0%)
HFO	2.46	2.02	(0.44)	(17.9%)
Power	3.16	2.32	(0.84)	(26.6%)
Water	1.28	0.98	(0.30)	(23.4%)
Diesel (mining)	2.13	1.77	(0.36)	(17.1%)
Salaries and Wages	1.28	2.09	0.80	62.7%

## Schedule

The construction schedule has increased from 18 to 24 months and production ramp-up has also increased from 6 months to a more conservative case of 15 months. This schedule estimates wet commissioning will be completed within 24 months after FID decision, with ore processing and production ramp-up commencing thereafter. First product into drums is anticipated approximately 2 months after ore processing commences.

The schedule estimated for Tumas is considered to be conservative and will be a target for further refinement during the ongoing detailed engineering.

## Financial Model

The financial model was updated based on the revised CAPEX and OPEX estimate data and various uranium pricing points, with a comparison back to the base case for the DFS Re-Costing, as summarised in Table 5 below.

For personal use only

**Table 5: Project Forecast Outcome at Various Uranium Pricing Points.**

Project Financials (Ungearred): Real Unless Stated	Unit	LOM			
		DFS Re-Costing US\$75/lb	2025 DFS		
			US\$82.50/ lb	FAM 2*	US\$110/ lb
U <sub>3</sub> O <sub>8</sub> Gross Revenue	US\$M	4,788	6,041	7,609	8,055
Gross Revenue: Total	US\$M	4,950	6,146	7,714	8,160
Site Operating Costs (during Production)	US\$M	(2,263)	(2,911)	(2,911)	(2,911)
Namibian State Royalty & Export Levy	US\$M	(160)	(198)	(249)	(264)
Cash Operating Margin	US\$M	2,463	2,963	4,480	4,911
Initial Capex (excl. Pre-Production Operating costs)	US\$M	(361)	(452)	(452)	(452)
Initial Capex (incl. Pre-Production Operating costs)	US\$M	(412)	(474)	(474)	(474)
Sustaining Capex and Closure	US\$M	(120)	(192)	(192)	(192)
Total Capital, Sustaining Capital & Pre-Production Operating Costs	US\$M	(532)	(667)	(667)	(667)
Undiscounted Cashflow Pre-Tax	US\$M	1,935	2,304	3,817	4,248
Tax Payable	US\$M	(722)	(857)	(1,424)	(1,585)
Undiscounted Cashflow After Tax	US\$M	1,213	1,446	2,393	2,663
C1 Cost (U <sub>3</sub> O <sub>8</sub> basis with V <sub>2</sub> O <sub>5</sub> by-product)	US\$/lb	34.35	38.60	38.61	38.62
All-in-Sustaining-Cost (U <sub>3</sub> O <sub>8</sub> basis with V <sub>2</sub> O <sub>5</sub> by-product)	US\$/lb	38.63	44.52	45.23	45.43
Project NPV (post-tax)	US\$M	570	577	972	1,153
Project IRR (post-tax)	%	27%	19%	25%	29%
Project Payback Period from Construction Start (Nominal)	Years	5	6	5	5
Project Payback Period from Production Start (Nominal)	Years	3	4	3	3
Maximum Project Drawdown (Nominal)	US\$M	407	492	490	487
Maximum Project Drawdown	US\$M	400	479	477	474

\* TradeTech Uranium Market Study 2024: Issue 4 Forward Availability Model Base Case (real US\$/lb U<sub>3</sub>O<sub>8</sub>) (FAM2) - translates to US\$104/lb average realised price for LOM.

For the first 10 and 20 operating years of the Project, C1 operating cost per pound is materially lower than the LOM average, as detailed in Table 6 below. While the project life is now 30 years, the later part of the LOM will be treating the low-grade portion of the Ore Reserves. Additionally, there remains approximately 35% of the identified palaeochannels within the Mining Licence (ML) that are yet to be properly explored and the Company is confident that additional reserves will be developed when further exploration is undertaken during operations, allowing an extension of the higher levels of production beyond 20 years. This expectation is underpinned by the available Mineral Resources at Tubas, Tumas Central and Tumas 1E areas which are within the Tumas ML.

For personal use only

These identified Measured, Indicated and Inferred Mineral Resources amount to approximately 39.8 Mlb contain U<sub>3</sub>O<sub>8</sub>, but have not yet been either fully explored, nor converted to Ore Reserves (refer **Annexure B**).

**Table 6: Early Production Performance.**

C1 Cost (After Vanadium Offset)	First 10 Years (av)				First 20 Years (av)			
	\$pa (/1000)	\$/t	\$/lb U <sub>3</sub> O <sub>8</sub>	Mlb pa	\$pa (/1000)	\$/t	\$/lb U <sub>3</sub> O <sub>8</sub>	Mlb pa
2025 DFS	104,348	26.72	30.95	3.37	99,388	24.52	35.03	2.84
DFS Re-Costing	104,373	25.70	29.07	3.59	100,267	24.42	33.00	3.04

The 2025 DFS, incorporates inflationary impacts since the DFS Re-Costing and an increased contingency provision. These factors resulted in a moderate increase in the CAPEX estimate (within the 15% accuracy range of the DFS Re-Costing) and a moderate increase in the C1 operating cost estimate per tonne and per lb U<sub>3</sub>O<sub>8</sub>.

The construction schedule has been extended from 18 months to 24 months. Additionally, the commissioning ramp-up period has been increased from 6 months to 15 months which have had a negative impact on both NPV and IRR. Both are expected to be refined through further optimisation.

With the current term price at US\$80/lb U<sub>3</sub>O<sub>8</sub> and forecast to be US\$94/lb in 2027 (TradeTech monthly price indicator, March 2025), the Project is very robust.

### Final Investment Decision Deferred

The Deep Yellow Board has determined that, although the Project continues to show it is robust, the current uranium pricing does not provide sufficient incentive for developing a greenfield project.

The Board anticipates the uranium market will adjust with increased Term pricing in the short-to-medium-term. This is based on a conviction that current and projected supply will not be sufficient to meet expected demand unless essential price incentivisation occurs to encourage development of greenfield projects.

On this basis, the Board has deferred FID and will not commit to significant capital expenditure until uranium prices improve to significant levels and become fully reflective of the supply/demand situation.

The Board recognises the importance of maintaining momentum and ensuring the Company remains in a position to move quickly when markets improve. This approach also allows the Company to retain the team's strong technical expertise while improving shovel-readiness and de-risking development.

For personal use only

The following workstreams have been approved:

- **Detailed Engineering** – continue with engineering refinement of the process plant to enable more rapid transition to the construction execution phase. This additional time will potentially enable the implementation of additional improvements to enhance the long-term value of the Project, and further derisk the cost and schedule estimate;
- **Early Works** – progressing non-processing infrastructure, including powerlines, water pipeline and major roads, site offices, communications, and pre-construction camp work managed directly by the Deep Yellow Owner’s Team; and
- **Schedule Optimisation** – the execution schedule, commissioning ramp-up and mining schedules still need further optimisation from which further improved project economics are expected. The Board is confident that value will be achieved as this work is undertaken in the coming months.

The Execution Phase, being processing plant construction and associated works, to be undertaken by the appointed Engineering, Procurement and Construction Management (**EPCM**) contractor will not commence until the Board is satisfied with uranium price incentives.

## Project Funding

The Company continues to work closely with Nedbank as the Mandated Lead Arranger to coordinate and arrange the project financing. Deep Yellow is currently assisting the Independent Technical Expert with information to conclude their due diligence work on the Tumas Project. On conclusion of this, the Company will be in a position to go to market to secure lenders for the funding package. Continuing this work will also further derisk the project.

## Conclusion

Completing the carefully considered programs will ensure a seamless and quick transition to the Execution Phase once suitable market conditions exist. The interim activities will help ensure that project risks are further mitigated and that any delays to the full development are minimised.

Deep Yellow is led by a highly experienced and proven uranium team and Board who understand what it takes to build, develop and operate long-life uranium mines. Through this knowledge and understanding of the market, the Company will not proceed with full-scale construction until the uranium price reflects the mid to long-term demand forecasts and the significant increase in supply required to deliver into a growing market.

The Board has great confidence in the Tumas Project however it is committed to delivering maximum shareholder value and will await the inevitable higher uranium price that is expected.

Importantly, Deep Yellow remains in a strong financial position with a cash balance of A\$227 million as at 31 March 2025. Even with the anticipated spend on the early works infrastructure and detailed engineering, a group cash balance of A\$170-180 million is expected at 31 December 2025.

The Company has worked hard and with purpose to establish its two greenfields projects, consisting of Tumas in Namibia and Mulga Rock in Western Australia. This is at a time a chokepoint has come into existence in the supply sector which will not be remedied under current uranium pricing scenarios. Deep Yellow's own analysis exposes potential shortfalls in supply over the short to mid-term.

The Company's portfolio of projects, with its significant resource base, provides both geographic and development diversity. Deep Yellow is the only ASX company with two advanced projects both located in Tier-1 uranium jurisdictions.

Deep Yellow is committed to becoming a reputable and reliable supplier of uranium and has the capability to do so but will only proceed when market conditions change.



**JOHN BORSHOFF**  
Managing Director/CEO  
Deep Yellow Limited

*This ASX announcement was authorised for release by Mr. John Borshoff, Managing Director/CEO, for and on behalf of the Board of Deep Yellow Limited.*

## Contact

---

Investors:  
John Borshoff, Managing Director/CEO  
+61 8 9286 6999  
[john.borshoff@deepyellow.com.au](mailto:john.borshoff@deepyellow.com.au)

Media:  
Cameron Gilenko  
+61 466 984 953  
[cameron.gilenko@sodali.com](mailto:cameron.gilenko@sodali.com)

---

## About Deep Yellow Limited

Deep Yellow Limited is successfully progressing a dual-pillar growth strategy to establish a globally diversified, Tier-1 uranium company to produce 10+ Mlb pa.

The Company's portfolio provides both geographic and development diversity with the Company's two advanced projects – flagship Tumas, Namibia and Mulga Rock, Western Australia, both located in Tier-1 uranium jurisdictions.

Deep Yellow is well-positioned for further growth through development of its highly prospective exploration portfolio – Alligator River, Northern Territory and Omahola, Namibia with ongoing M&A focused on high-quality assets should opportunities arise that best fit the Company's strategy.

Led by a best-in-class team, who are Proved uranium mine builders and operators, the Company is advancing its growth strategy at a time when the need for nuclear energy is becoming the only viable option in the mid-to-long-term to provide baseload power supply and achieve zero emission targets. Importantly, Deep Yellow is on track to becoming a reliable and long-term uranium producer, able to provide production optionality, security of supply and geographic diversity.

## Relevant Information Regarding Preparation of the 2025 DFS

The underlying Mineral Resource estimate (**MRE**) has been classified into Measured, Indicated and Inferred categories of which Measured and Indicated category material only was used to form the basis of the ORE. The MRE was classified on the basis of the sample variability, estimation search distances and predominant drill spacing with portions of the MRE block model being explicitly coded via digitised polygons.

Given the near surface nature of the deposit conventional truck and shovel open pit mining has been used for all pit optimisations, design and scheduling. No additional mining dilution and recovery factors have been applied to the MIK estimated resources since they are considered to be a recoverable resource and include the estimation of a block support adjustment to account for the application of an approximate 4 m x 4 m x 3 m selective mining unit and an adjustment to account for the additional information that will be available at the time of mining from grade control sampling.

The metallurgical process proposed for the treatment of the Tumas ore is similar to that used at the nearby Langer Heinrich Mine which is currently in operation. The process consists of:

- beneficiation through grinding and classification by size, with barren coarse material rejected to tailing;
- alkali (carbonate/bicarbonate) leaching at elevated temperature;
- CCD washing of the leach discharge;
- membrane concentration of the pregnant liquor from the CCD circuit;
- recovery of vanadium as  $V_2O_5$  (red cake) from the membrane retentate liquor;
- recovery of uranium as  $U_3O_8$  (yellow cake) from the vanadium recovery section barren liquor; and
- disposal and permanent storage of process tailings into in-pit tailings storage facilities.

The only economic mineral present in the Tumas ore is carnotite, which is a carbonate mineral of uranium and vanadium. Two separate ore types have been identified in the Tumas ORE and no material variation in processing performance has been identified. The same overall metallurgical recovery, of 93.3% is appropriate for both ore types and is used in this study. The only potentially deleterious element in the Tumas ore is vanadium and the metallurgical process has been developed to remove (as a by-product) the vanadium that is co-leached with the uranium.

A lower MIK block cut-off grade of 100 ppm  $U_3O_8$  has been applied in estimating the Ore Reserve. Due to strategic objectives of target feed grades, this lower cut-off is slightly elevated from the calculated cut-off grade of 81 ppm  $U_3O_8$  based on mining, processing costs, processing recoveries and expected uranium price.

An Environmental Impact Assessment (**EIA**) was undertaken for the Tumas Project and a subsequent Environmental Clearance Certificate (**ECC**) issued prior to the grant of the Mining Licence ML237. The Tumas Project is located in Namibia, which has a long and continuous (since the 1970s) history of uranium mining and export. Waste rock has been determined as non-acid generating and will be stored both in-pit and in surface waste rock dumps.

The work to which the exploration results relate was undertaken on Mining Licence (**ML**) 237 which was granted to Reptile Uranium Namibia (Pty) Ltd (**RUN**) in September 2023. RUN is a wholly owned subsidiary of Reptile Mineral Resources and Exploration (Pty) Ltd (**RMR**), the latter being the operator. The Mining Licence is in good standing and valid until 21 September 2043. ML237 is located within the Namib-Naukluft National Park in Namibia. There are no known impediments to the Tumas Project beyond Namibia's standard permitting procedures.

The region in which the Tumas Project is located has:

- established road (tarmac-covered road within 10 km of the proposed treatment plant site) access;
- established residential towns suitable for the projected needs of the Project within 70 km of the Project location;
- established power (20 km from the proposed treatment plant site to the proposed connection point) and water (~75 km from the proposed treatment plant site to the connection point) infrastructure;
- an established class 7 port (suitable for the export of uranium concentrates) ~70 km from the proposed treatment plant site;
- an international airport ~60 km from the proposed treatment plant site; and
- an established telephone communication network.

The 2025 DFS referred to in this announcement is based on the Mineral Resource and Ore Reserve of 5 October 2021, 3 February 2022 and 18 December 2024. The estimated Measured and Indicated Mineral Resource underpinning the production target has been prepared by an Independent Competent Person in accordance with the requirements of the JORC Code. Accordingly, Deep Yellow has concluded that it has reasonable grounds for disclosing the production targets.

The above ground capital costs were prepared by independent and globally recognised engineering from Ausenco Services Pty Ltd. Processing and engineering works for the DFS were developed to support capital and operating estimates (and following AUSIMM Guidelines for this study level) and both are determined to have +15% / -10% accuracy limits.

The pricing for commodities used in the DFS was based on independent market research and the economic analysis results should be treated as preliminary in nature and caution should be exercised in their use as a basis for assessing project feasibility.

Statements regarding plans with respect to Deep Yellow's mineral properties are forward-looking statements. There can be no assurance that Deep Yellow's plans for the development of its mineral properties will proceed as expected. There can be no assurance that Deep Yellow will be able to confirm the presence of mineral deposits, that any mineralisation will prove to be economic or that a mine will be successfully developed on any of Deep Yellow's mineral properties.

Unless otherwise stated, all cashflows are in US Dollars and all years are calendar years.

For personal use only

## Competent Persons' Statements

### Namibian Mineral Resources and Ore Reserves

Where there is information in this announcement relating to the Tumas Mineral Resource estimate and Ore Reserve, the Company confirms that it is not aware of any new information or data that materially affects the information included in previous announcements and in particular the announcements released to ASX on 2 February 2023 entitled “*Strong Results from Tumas Definitive Feasibility Study*”, the Re-Costed DFS on 12 December 2023 entitled “*DFS Review Strengthens Tumas Project’s Flagship Status as a Long-Life, World-Class Uranium Operation*” and the Upgraded Ore Reserve on 18 December 2024 entitled “*Updated Ore Reserve Upgrades Tumas Project*”. All material assumptions and technical parameters underpinning the Mineral Resource and Ore Reserve estimates continue to apply and have not materially changed.

The information in this announcement as it relates to Exploration results Mineral Resource estimates and Ore Reserves was based on, and fairly represents, information and supporting documentation compiled by Mr. Martin Hirsch, a Competent Person who is a Professional Member of the Institute of Materials, Minerals and Mining (UK) and the South African Council for Natural Science Professionals. Mr. Hirsch, who is currently the Manager, Resources & Pre-Development for Reptile Mineral Resources and Exploration (Pty) Ltd, has sufficient experience which is relevant to the style of mineralisation and type of deposit under consideration and to the activity which he is undertaking, to qualify as a Competent Person as defined in the 2012 Edition of the Australasian Code for Reporting of Exploration Results, Mineral Resources and Ore Reserves. Mr. Hirsch consents to the inclusion in this announcement of the matters based on the information in the form and context in which it appears. Mr. Hirsch holds shares in the Company.

Where the Company refers to JORC 2004 resources in this report, it confirms they have not been updated to comply with JORC 2012 on the basis that the information has not materially changed since it was last reported, however these are currently being reviewed to bring all resources up to JORC 2012 standard.

### Project and Technical Expertise

Mr. Darryl Butcher is a process engineer/metallurgist working for Deep Yellow and has sufficient experience to advise the Company on matters relating to mine development and uranium processing, project scheduling, processing methodology and project capital and operating costs. Mr. Butcher is satisfied that the information provided in the announcement has been determined to a Feasibility Study level of accuracy and that the relevant modifying factors determined by the 2025 DFS are suitable to use as modifying factors for the updated financial outcomes.

### **Ausenco Services Pty Ltd (Lead Engineer)**

Ausenco is engaged to assist in compiling the 2025 Feasibility Study document by assimilating inputs from various external subject matter experts and providing design engineering services, project execution methodology and scheduling, vendor and contractor pricing, and developing project capital and operating cost estimates. Ausenco has experience in the development of feasibility studies and project execution of mineral processing facilities of similar scope and complexity globally, including Africa. Ausenco is satisfied that the information provided in the announcement has been determined to a Feasibility Study level of accuracy.

Ausenco is a global company redefining what's possible. The team is based out of 21 offices working across 5 continents to deliver services worldwide. Combining deep technical expertise with a 30-year track record, Ausenco delivers innovative, value-add consulting, studies, project delivery, asset operations and maintenance solutions to the minerals and metals and industrial sectors ([www.ausenco.com](http://www.ausenco.com)).

### **Forward Looking Statements**

Any statements, estimates, forecasts or projections with respect to the future performance of Deep Yellow and/or its subsidiaries contained in this announcement are based on subjective assumptions made by Deep Yellow's management and about circumstances and events that have not yet taken place. Such statements, estimates, forecasts and projections involve significant elements of subjective judgement and analysis which, whilst reasonably formulated, cannot be guaranteed to occur. Accordingly, no representations are made by Deep Yellow or its affiliates, subsidiaries, directors, officers, agents, advisers or employees as to the accuracy of such information; such statements, estimates, forecasts and projections should not be relied upon as indicative of future value or as a guarantee of value or future results; and there can be no assurance that the projected results will be achieved.

### **Annexures**

Following on from this are the following:

**Annexure A – Executive Summary Tumas 2025 DFS**

**Annexure B – JORC Tables**

# Annexure A

Tumas Project  
Definitive Feasibility Study Report – Addendum 1  
Chapter 1 – Executive Summary



**Deep Yellow Limited**

**Tumas Project**

**Definitive Feasibility Study Report – Addendum 1**

**Chapter 1 – Executive Summary**

For personal use only

# Annexure A (continued)

Tumas Project  
Definitive Feasibility Study Report – Addendum 1  
Chapter 1 – Executive Summary



<b>Contents</b>		<b>Page</b>
<b>1.</b>	<b>Executive Summary .....</b>	<b>6</b>
1.1	<b>Synopsis.....</b>	<b>6</b>
1.2	<b>Introduction.....</b>	<b>7</b>
1.2.1	Project Background .....	7
1.2.2	Property Location .....	8
1.3	<b>Project History .....</b>	<b>9</b>
1.4	<b>Legal Framework.....</b>	<b>9</b>
1.5	<b>Environmental Social Governance .....</b>	<b>10</b>
1.6	<b>Environmental Impact Assessment .....</b>	<b>11</b>
1.6.1	Environmental Setting and Baseline .....	11
1.6.2	Environmental Impact Assessment .....	14
1.7	<b>Geology and Mineral Resource .....</b>	<b>17</b>
1.7.1	Geological Setting and Mineralisation .....	17
1.7.2	Drilling .....	18
1.7.3	Sample Preparation and Analysis .....	18
1.7.4	Data Verification .....	19
1.7.5	Geological Interpretation .....	19
1.7.6	Mineral Resource Estimation.....	21
1.7.7	Mineral Resource Estimate .....	24
1.8	<b>Mining and Ore Reserves.....</b>	<b>24</b>
1.8.1	Mine Design Considerations .....	24
1.8.2	Pit Optimisation .....	25
1.8.3	Waste Rock Characterisation .....	26
1.8.4	Waste Rock Management .....	26
1.8.5	Mine Production Schedule .....	27
1.8.6	Mine Contractor, Equipment and Facilities .....	29
1.8.7	Ore Reserves.....	30
1.9	<b>Geometallurgy .....</b>	<b>30</b>
1.10	<b>Metallurgy .....</b>	<b>31</b>
1.10.1	Introduction .....	31
1.10.2	Metallurgical Testwork Programs.....	32
1.10.3	Sample Selection and Composite.....	33
1.10.4	Beneficiation.....	34
1.10.5	Leach.....	34
1.10.6	Solid-Liquid Separation.....	35
1.10.7	PLS Concentration .....	35
1.10.8	Vanadium Precipitation and Refining.....	35
1.10.9	Uranium Precipitation and Refining.....	36
1.10.10	Causticisation.....	36
1.10.11	Crystallisation.....	36
1.10.12	Carbonation.....	37

For personal use only

# Annexure A (continued)

Tumas Project  
Definitive Feasibility Study Report – Addendum 1  
Chapter 1 – Executive Summary



<b>1.11</b>	<b>Processing</b> .....	<b>37</b>
1.11.1	Process Design .....	38
1.11.2	Process Description .....	39
1.11.3	Plant Layout .....	40
<b>1.12</b>	<b>Tailings and Water Management</b> .....	<b>41</b>
1.12.1	Tailings Characterisation .....	41
1.12.2	Tailings Disposal.....	41
1.12.3	Sodium Sulphate Pond.....	42
1.12.4	Hydrogeology .....	42
1.12.5	Hydrology.....	43
1.12.6	Surface Water Management.....	43
1.12.7	Water Balance.....	44
<b>1.13</b>	<b>Infrastructure and Services</b> .....	<b>44</b>
1.13.1	Site Access .....	45
1.13.2	Power Supply .....	46
1.13.3	Water Supply.....	46
1.13.4	Site Infrastructure .....	46
1.13.5	Site Accommodation .....	46
<b>1.14</b>	<b>Project Execution</b> .....	<b>46</b>
<b>1.15</b>	<b>Capital Costs</b> .....	<b>49</b>
<b>1.16</b>	<b>Operating Costs</b> .....	<b>51</b>
1.16.1	Overall Operating Costs.....	51
1.16.2	Mining Costs .....	52
1.16.3	Processing .....	52
<b>1.17</b>	<b>Operating Strategy</b> .....	<b>54</b>
<b>1.18</b>	<b>Marketing</b> .....	<b>56</b>
<b>1.19</b>	<b>Financial Analysis</b> .....	<b>58</b>
<b>1.20</b>	<b>Project Finance</b> .....	<b>60</b>
<b>1.21</b>	<b>Risk</b> .....	<b>60</b>

## Figures

<b>Figure 1: Tumas Project Location.</b> .....	<b>8</b>
<b>Figure 2: 3D View of Tumas 1 and Tumas 2 Deposits.</b> .....	<b>18</b>
<b>Figure 3: Oblique View of Tumas 1 East in Relation to Tumas 1 and Tumas 2 Deposits.</b> .....	<b>20</b>
<b>Figure 4: Tumas 1 East Wireframes, Oblique View.</b> .....	<b>22</b>
<b>Figure 5: Tumas 1 and Tumas 2 Mineralised Domains, Plan View.</b> .....	<b>22</b>
<b>Figure 6: Tumas 3 Wireframes, Oblique View.</b> .....	<b>23</b>
<b>Figure 7: Tubas Wireframes, Oblique View</b> .....	<b>23</b>
<b>Figure 8: Tumas 3 Tonnage/Cashflow Chart.</b> .....	<b>26</b>
<b>Figure 9: Tumas 3 WRD Layout.</b> .....	<b>27</b>
<b>Figure 10: Ex-pit Material Movement by Deposit.</b> .....	<b>28</b>
<b>Figure 11: Tumas 3 Ex-pit Material Movement by Stage</b> .....	<b>28</b>

For personal use only

# Annexure A (continued)

Tumas Project  
Definitive Feasibility Study Report – Addendum 1  
Chapter 1 – Executive Summary



Figure 12: Mill Feed Tonnes and Grade by Ore Type. ....	29
Figure 13: Block Flow Diagram. ....	32
Figure 14: Schematic Process Flow Diagram.....	40
Figure 15: Plant Layout. ....	41
Figure 16: Tailings Deposition Sequencing. ....	42
Figure 17: Groundwater Level Drawdown Levels in Year 30. ....	43
Figure 18: Offsite Infrastructure Layout. ....	44
Figure 19: On site Infrastructure Layout.....	45
Figure 20: Distribution of Processing and General Expenses Operating Costs. ....	53
Figure 21: Tumas Management Structure. ....	55
Figure 22: Reference Scenario Supply, tU. ....	58
Figure 23: Tumas Project Sensitivity Spider Chart. ....	60
Figure 24: Qualitative Scale of Risk by Impact. ....	62

## Tables

Figure 1: Tumas Project Location. ....	8
Figure 2: 3D View of Tumas 1 and Tumas 2 Deposits. ....	18
Figure 3: Oblique View of Tumas 1 East in Relation to Tumas 1 and Tumas 2 Deposits. ....	20
Figure 4: Tumas 1 East Wireframes, Oblique View. ....	22
Figure 5: Tumas 1 and Tumas 2 Mineralised Domains, Plan View. ....	22
Figure 6: Tumas 3 Wireframes, Oblique View. ....	23
Figure 7: Tubas Wireframes, Oblique View.....	23
Figure 8: Tumas 3 Tonnage/Cashflow Chart. ....	26
Figure 9: Tumas 3 WRD Layout. ....	27
Figure 10: Ex-pit Material Movement by Deposit. ....	28
Figure 11: Tumas 3 Ex-pit Material Movement by Stage ....	28
Figure 12: Mill Feed Tonnes and Grade by Ore Type. ....	29
Figure 13: Block Flow Diagram. ....	32
Figure 14: Schematic Process Flow Diagram.....	40
Figure 15: Plant Layout. ....	41
Figure 16: Tailings Deposition Sequencing. ....	42
Figure 17: Groundwater Level Drawdown Levels in Year 30. ....	43
Figure 18: Offsite Infrastructure Layout. ....	44
Figure 19: On site Infrastructure Layout.....	45
Figure 20: Distribution of Processing and General Expenses Operating Costs. ....	53
Figure 21: Tumas Management Structure. ....	55
Figure 22: Reference Scenario Supply, tU. ....	58
Figure 23: Tumas Project Sensitivity Spider Chart. ....	60
Figure 24: Qualitative Scale of Risk by Impact. ....	62

For personal use only

# Annexure A (continued)

Tumas Project  
Definitive Feasibility Study Report – Addendum 1  
Chapter 1 – Executive Summary



## Instruction to Readers

After the completion of the 2 February 2023 Tumas Definitive Feasibility Study Report (**DFS**) and the December 2023 Tumas DFS CAPEX & OPEX Re-Costing Study (**DFS Re-Costing**), Deep Yellow Limited (**Deep Yellow** or **Company**) undertook a competitive bidding process to identify a suitable third-party engineering services provider to complete the detailed engineering and then provide project implementation services, once the Deep Yellow Board (**Board**) has approved Project development and endorsed a final investment decision (**FID**).

The bidding process commenced in December 2023 and in July 2024, Deep Yellow selected Ausenco Services Pty Ltd (**Ausenco**) as the successful bidder for the Tumas Project (**Project**), Detailed Engineering and EPCM Services. Ausenco were engaged to undertake the role in two stages:

1. Separable Portion 1 (**SP1**), during which the process design for the Project would be optimised in line with recommendations made in the DFS and the engineering definition and associated capital cost estimate, operating cost estimate and execution schedule increased or further developed to a point sufficient to allow the Board to confidently make a FID from a suitably informed basis. Additional effort in product marketing and financing was to be undertaken by the Company in parallel to support the engineering work. This latter work is ongoing; and
2. Separable Portion 2 (**SP2**), or the EPCM project execution phase after the FID, and at the Company's sole discretion.

This Executive Summary is a complete re-write of the original DFS section, whereas each of the other addenda to the 2025 DFS have been written as an exception report to the relevant section of the DFS. Collectively, they supersede the DFS Re-Costing. The addenda have been written to inform the reader in a succinct and accurate manner and only material changes in the Project are identified and discussed.

All dollars in the document are US dollars unless stated otherwise.

For personal use only

# Annexure A (continued)

Tumas Project  
Definitive Feasibility Study Report – Addendum 1  
Chapter 1 – Executive Summary



## 1. Executive Summary

### 1.1 Synopsis

This report presents the findings of the 2025 DFS which has been revised as of March 2025. The objective of the Tumas Project is to develop a facility to treat ore at a rate of up to 4.2 Mt/y from the Tumas 1, Tumas 2, Tumas 3, Tumas 1 East and Tubas mineral resources through a beneficiation, leaching, solid liquid separation and uranium/vanadium recovery process to produce up to 3.6 Mlb/y uranium yellowcake ( $U_3O_8$ ) product and up to 1.1 Mlb/y vanadium by-product.

The key outcomes are:

- the overall project life will be 30 years from commencement of ore processing;
- the mine will be a series of conventional shallow open-cut truck and shovel operations using contract mining;
- the process route consists of a beneficiation process to reject barren material, leaching, solid liquid separation, pregnant leach solution (**PLS**) concentration, vanadium recovery, uranium recovery and uranium barren liquor (**UBL**) treatment;
- tailings are returned to mined-out pits, with waste material used to construct dividing walls as interim boundaries and as required;
- the report concludes, based on CSIRO modelling, that the tailings from the process will be relatively benign and represent a true walk-away option at closure;
- the project also includes the construction of a 13.5 km site access road, a 22 km 220 kV powerline and a 65 km water supply pipeline;
- the initial capital cost for the project is \$474M, inclusive of pre-production costs. Key components of the initial capital are \$284M direct cost for the process plant, \$14M for mining, \$17M for onsite infrastructure, \$25M for off-site infrastructure, \$72M for indirect, EPCM and Owners' costs and \$39M for project contingency. Capitalised pre-production costs include \$18M for pre-production mining and \$5M for processing and administration (operational readiness and manning build-up);
- using the TradeTech FAM-2 Issue 4 uranium price deck (averaged realised price of US\$104/lb  $U_3O_8$ , a vanadium price of US\$5.00/lb  $V_2O_5$  and a discount rate of 8%, the financial analysis for the project determined a real post-tax project Net Present Value (**NPV**) of \$972M and a real, post-tax Internal Rate of Return (**IRR**) of 24.8%; and
- C1 operating cost after a vanadium credit of \$1.43 /lb  $U_3O_8$  is \$38.61/lb  $U_3O_8$  and the All-In-Sustaining-Cost (**AISC**) is US\$45.23 /lb  $U_3O_8$ .

On the basis that the project life, NPV, IRR and C1 operating cost fall materially within the development criteria of the Company, it is recommended that:

- the pre-development of the Project continue as proposed; and
- initial engagement with markets and sources of finance for the Project be advanced.

For personal use only

# Annexure A (continued)

Tumas Project  
Definitive Feasibility Study Report – Addendum 1  
Chapter 1 – Executive Summary



## 1.2 Introduction

Deep Yellow Limited (**Deep Yellow** or **the Company**) is an emerging global uranium leader, developing a geographically diversified and advanced portfolio, to provide security and certainty of supply into a growing market.

Following completion of the merger with Vimy Resources Ltd in August 2022, Deep Yellow holds a globally significant uranium resource base (428.2 Mlb U<sub>3</sub>O<sub>8</sub>). The Company is uniquely positioned as one of the few uranium companies with credible, diverse, multi-mine asset exposure globally and internal ability to execute through development and to production.

Importantly, the Company is successfully progressing its dual-pillar strategy to establish a multi-mine operation with capacity to produce 10+ Mlb/y.

The most advanced project in Deep Yellow's portfolio is the Tumas Project in Namibia. Since 2017, Deep Yellow's exploration and development work has grown the Tumas Project significantly in size and scale, resulting in a 30-year life of mine and Ore Reserves of 79.3 Mlb. Substantial potential for further resource identification remains.

### 1.2.1 Project Background

Exploration at Tumas, since 2016, when the current Deep Yellow management team took control of the project, has been highly successful. The Project's palaeochannel/ calcrete resource has increased nearly four-fold since 2016 (mainly at the Tumas 3 and Tumas 1 East resource areas) at an extremely low and impressive discovery cost of A\$0.115/lb U<sub>3</sub>O<sub>8</sub>.

A Scoping Study on the Tumas deposits was completed at the end of 2019, with positive results providing the Board with confidence to proceed immediately to a formal Prefeasibility Study (**PFS**).

The PFS was completed in early 2021 and delivered robust results in line with, and in some cases better than, the assumptions used for the Scoping Study. This highlighted a strong economic case for the Tumas Project and justified the immediate commencement of a DFS into the future development of the Project, which was completed in February 2023 (**DFS**).

Subsequent to the DFS, a re-price of capital and operating costs was completed to address the perceived potential overhang of Covid 19 market disturbance. This additional work was completed and reported, by way of an addendum to the DFS, in December 2023 (**DFS Re-Costing**).

Finally, the Project was subjected to a detailed optimisation, with associated capex, opex and schedule review, the results of which are presented have been incorporated as further addenda to the original DFS in this March 2025 document (**2025 DFS**).

For personal use only

# Annexure A (continued)

Tumas Project  
Definitive Feasibility Study Report – Addendum 1  
Chapter 1 – Executive Summary



## 1.2.2 Property Location

The Tumas Project includes the Tumas 1, Tumas 2, Tumas 3, Tumas 1 East and Tubas Red Sand/ Calcrete orebodies and is located in Namibia about 80 km ESE from the coastal town of Swakopmund and 80 km ENE from the Seaport of Walvis Bay. The Walvis Bay port is a Class 7 port which has exported yellowcake since the 1970s. The Project area is accessible via the sealed C28 road (refer Figure 1).

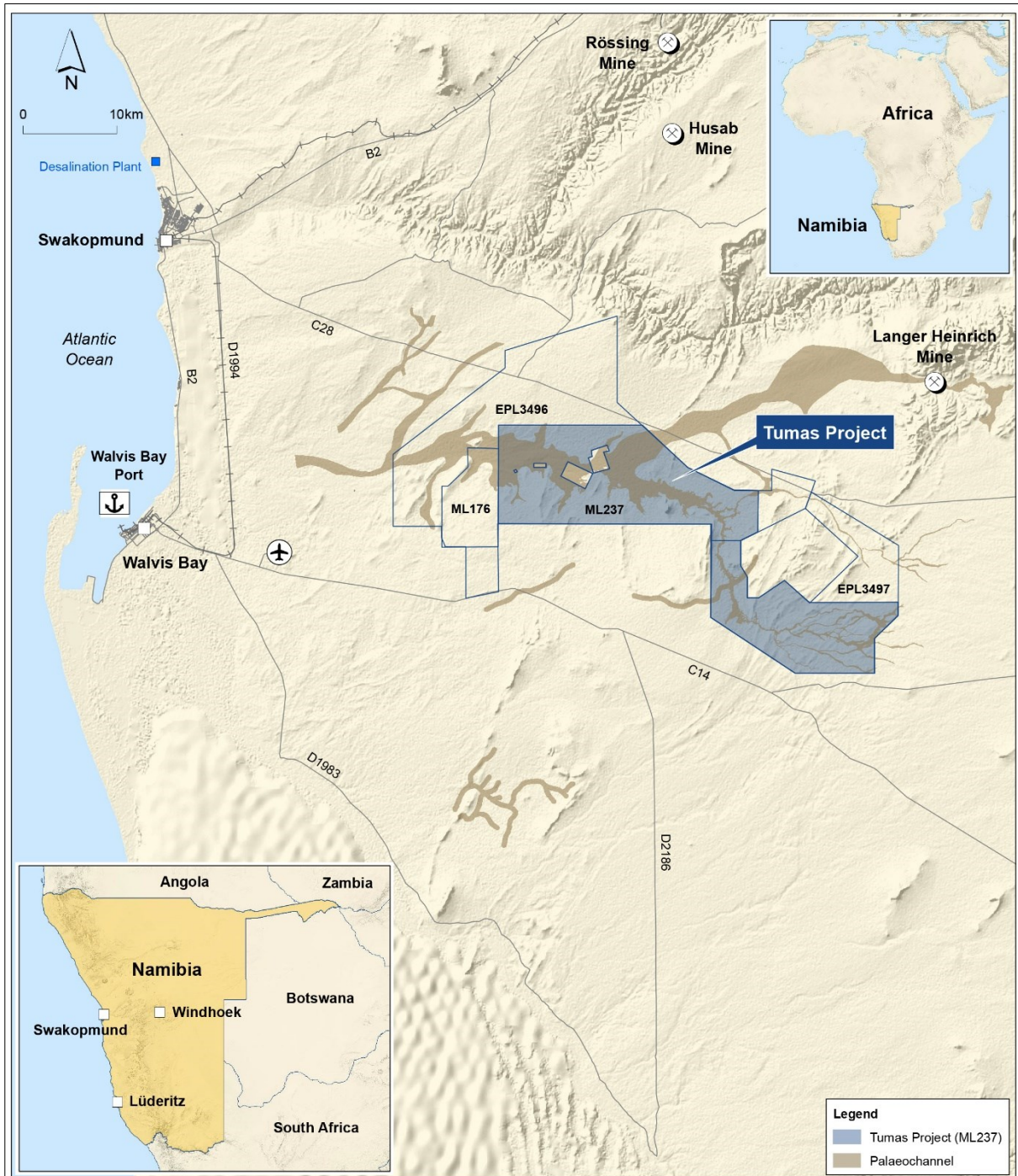

Figure 1: Tumas Project Location.

# Annexure A (continued)

Tumas Project  
Definitive Feasibility Study Report – Addendum 1  
Chapter 1 – Executive Summary



## 1.3 Project History

Anglo American and Falconbridge explored the Tumas palaeochannel from the mid-1970s to the early 1980s. Falconbridge identified uranium mineralisation in the Oryx Area (now Tumas 3) and Anglo American drilled the Tubas Red Sand mineralisation. In 2005, Reptile Mineral Resources and Exploration (Proprietary) Limited (**RMR**) acquired Reptile Investment Four (Proprietary) Limited which was, in 2006, renamed Reptile Uranium Namibia (Proprietary) Limited (**RUN**).

RUN acquired tenure of the Project in 2006 under EPL3496 and 3497. Deep Yellow, through its wholly owned subsidiary Deep Yellow Namibia (Pty) Ltd, acquired RMR in 2008. In late 2016 the newly-placed current Deep Yellow management team re-evaluated all previous drill and geophysical data resulting in a new geological model and exploration strategy targeting the prospective Tumas palaeochannel for substantial resource increases. Initial drilling in 2017 and 2018 concentrated on Tumas 3 resulting in a maiden calccrete Inferred Mineral Resource of 33.1 Mlb  $U_3O_8$  at 378 ppm. An in-house Scoping Study in 2019 provided encouraging results and was followed by a PFS in 2020/21. The PFS resulted in a maiden ore reserve of 40 Mt of 344 ppm  $U_3O_8$  containing 30.1 Mlb  $U_3O_8$ , an 11.5-year mine life and a post-tax NPV8.6 of US\$208M ungeared.

The DFS, and associated work, increased this to a total Indicated and Inferred Resource Estimate of 200.5 Mt at 258 ppm  $U_3O_8$  containing 114.0 Mlb  $U_3O_8$ . Subsequent exploration and resource definition work undertaken for this 2025 DFS, plus the incorporation of the Tubas deposits into Tumas Project, has further expanded the resource estimate to a total Measured, Indicated and Inferred Resource Estimate of 251.5 Mt at 250 ppm  $U_3O_8$  containing 136.9 Mlb  $U_3O_8$ . The Ore Reserve Estimate (100 ppm  $U_3O_8$  cut-off) associated with this resource estimate is 120.1 Mt at 298 ppm  $U_3O_8$  containing 79.3 Mlb  $U_3O_8$ , representing a significant increase in ore reserves.

## 1.4 Legal Framework

The management and regulation of mining activities in Namibia falls within the jurisdiction of the Ministry of Mines and Energy (**MME**), with the environmental regulations guided and implemented by the Directorate of Environmental Affairs (**DEA**) within the Ministry of Environment, Forestry and Tourism (**MEFT**).

The MME granted RUN tenure of Exclusive Prospecting Licences (**EPL**) 3496 and 3497 (refer Figure 1). In June 2021 RUN submitted a Mining Licence application (MLA237) to cover the Tumas and Tubas resources. The MME provided a preparedness to grant notification on 10 August 2022. RUN received notification from MME that the grant of ML237 was subject to the provisions of the relevant Environmental Clearance Certificates (**ECC**) for the Project and associated infrastructure. An Environmental Impact Assessment (**EIA**) and Environmental Management Plan (**EMP**) for the Tumas Project (Namisun, 2023a&b, 2023b), including all environmental and social aspects, were submitted and approved by the Namibian Authorities in 2023. EIAs and EMPs for the water pipeline and powerline associated with the Tumas Project were also submitted and approved. MEFT issued ECCs for the Tumas Project, water pipeline and overhead powerline in September 2023 which allows the Project to proceed.

For personal use only

## Annexure A (continued)

Tumas Project  
Definitive Feasibility Study Report – Addendum 1  
Chapter 1 – Executive Summary



### 1.5 Environmental Social Governance

Effective and successful corporate governance is an ongoing focus of the Deep Yellow Board. The Board and management are committed to the creation of shareholder value and recognise that high standards of governance are integral to that objective.

The directors of Deep Yellow have approved policies which they believe will focus their attention, and that of their executives, on the extremely important pillars of accountability, risk management and ethical conduct. Deep Yellow is committed to ensuring that there is effective environmental management across all aspects of its operations. In accordance with Deep Yellow's corporate governance framework discussed above, the Company operates under an Environmental Policy. The Environmental Policy provides a framework to achieve a high standard of environmental performance across its operations in order to both minimise and mitigate environmental impacts. Deep Yellow's operational sites are required to establish an Environmental Management System (**EMS**) to ensure that environmental impacts are managed in a planned, controlled, monitored, recorded and auditable manner.

The Company believes that exploration and mining activity can play a central role in sustainable community development by acting as a catalyst for positive economic and social change. Deep Yellow has a Community Relations Policy that provides a framework for working with the communities where it conducts its operations. Deep Yellow also has a Human Rights Policy that provides a framework for the Company to help protect the human rights of its stakeholders, and to prevent human rights violations from occurring at the Company's operations.

Deep Yellow believes that attaining a high level of performance in occupational health and safety is critical to the long-term success of its business. Deep Yellow is committed to provide and maintain a safe and healthy work environment, with the target of zero incidences of occupational injuries and illnesses in the workplace. This includes promotion of good mental health within Deep Yellow's workforce. Deep Yellow has an Occupational Health and Safety Policy which provides a framework for the Company to achieve its occupational health and safety objectives while achieving its operational aims. The Deep Yellow Integrated Management System (**IMS**) is a Company-wide system that describes the mandatory requirements for effective health, safety, environmental and quality practices across all Deep Yellow's activities and operations.

Deep Yellow considers excellence in radiation management performance is essential to business success and the Company is fully committed to achieving minimum radiation exposure to its workers, members of the public and the surrounding natural environment. Deep Yellow has a Radiation Policy which provides the overarching framework for the business to achieve a high standard of radiation management performance. The Policy sets out the objectives and strategy to achieve minimal radiation exposure to people and the environment. A Radiation Management System (**RMS**) is in place to address the radiation risks associated with handling radioactive ore and concentrates once the Tumas Project is operational and to reduce the risks to as low as reasonably achievable.

For personal use only

# Annexure A (continued)

Tumas Project  
Definitive Feasibility Study Report – Addendum 1  
Chapter 1 – Executive Summary



## 1.6 Environmental Impact Assessment

### 1.6.1 Environmental Setting and Baseline

The Tumas Project area is located in the Namib-Naukluft National Park (**NNNP**) in the Erongo Region of Namibia, approximately 40 km east of Walvis Bay.

#### 1.6.1.1 Climate

The daytime wind field is dominated by winds from the west-southwest and west while at night weaker winds prevail mostly from the northwest, west, and east. Seasonal variation shows predominantly north-westerly, westerly and west-north-westerly winds in summer (October - March), changing to west-south-westerly winds during the autumn months (April - May). During the winter months (June - August), high speed north-easterly winds dominate, referred to as the east-winds. During the spring months (September - November) the westerly winds (west-south-westerly, westerly, north- westerly and west-north-westerly winds) return.

Average daily maximum temperatures range from 42°C in November to 25°C in July, with daily minima ranging from 14°C in January to 7°C in September. The average annual rainfall in the region ranges from about 15 mm at the coast, to about 35 mm around 100 km inland. However, rainfall is extremely variable, patchy, and unreliable and may not occur for many years. The region receives significant amounts of moisture from fog or dew, particularly near the coast where it receives, on average, as much or more precipitation from fog than from rainfall. While average annual rainfall at the Project area is very low, most of the rainfall occurs due to high intensity and short duration localised storm events.

#### 1.6.1.2 Topography and Soils

The Project area is characterised by a gently westward sloping peneplain, punctuated by occasional outcrops and inselbergs, and dissected by an extensive network of washes of various depths and extent.

The types of soils found on or near the Project area include gypsum soil and calcrete. Generally, the gypsum soils correspond to the area where lichens grow on gravel plains, which is most evident at the western part of the Project area. Towards the east gypcrete occurrences decrease and calcrete becomes more dominant. Underlying the grassy plains in parts of the Project area are hard substrates comprised of coarse sandy material. These hard sandy plains are usually covered by sharp and angular gravel.

#### 1.6.1.3 Surface Water

The regional hydrological setting of the Project area falls within the Tumas River Catchment, which is separated from the larger Kuiseb River catchment in the south and the Swakop River catchment in the north. The confluence of the Tumas and Tubas Rivers lies towards the western extent of the Project area. The Tumas and Tubas Rivers flow east to west and have many smaller tributaries. Both rivers are ephemeral rivers with episodic flows which are linked to the higher rainfall events during summer months.

For personal use only

## Annexure A (continued)

Tumas Project  
Definitive Feasibility Study Report – Addendum 1  
Chapter 1 – Executive Summary



The Project area is drained mainly by minor drainage lines and washes flowing in an east-west direction to join the Tumas River. These do not have regular surface flow because any surface water flow seeps into the ground and recharges the groundwater.

### 1.6.1.4 Groundwater

Monitoring bores in the Tumas Project area have intersected three groundwater systems – the shallow alluvium, the palaeochannel aquifer and the fractured basement aquifer. Most of the boreholes in the alluvium were found to be dry at the time of their drilling. The groundwater levels in the palaeochannel and basement aquifers generally range between 2 and 30 m below ground level.

The groundwater quality in the Tumas River and Tubas River is classified as moderately to highly saline water and therefore not suitable for human consumption. The uranium concentrations in groundwater range from 0.05 mg/L to 0.2 mg/L.

### 1.6.1.5 Vegetation and Flora

The vegetation in the Project area is largely grassland and shrubland, with the latter mostly confined to washes and rivers. The Project area falls overall into the vegetation type of the *Arthroerua leubnitziae* and *Zygophyllum stapffii* zone. Twelve landforms have been delineated in the Project area which can be divided into the broad categories of plains, rivers, inselbergs and mountains. The densest vegetation is found in the rivers, where the hummock-forming shrub *Salsola nollothensis* grows.

Around 206 plant species may be expected to be found in the region, 96 of which have been recorded in the Project area. This includes 22 legally protected or Convention on International Trade in Endangered Species 2 (CITES 2) species, 48 range-restricted species (endemic or near-endemic) and one species listed vulnerable according to red-list criteria. All trees in the Project area are protected. Seven plant species that are of particular interest in the Project area are the nara plant (*Acanthosicyos horridus*), elephants' foot (*Adenia pechuelii*), the bulb *Ammocharis deserticola*, the stone plants (*Lithops gracilidelineata* and possibly *Lithops ruschiorum*), *Salsola nollothensis* and *Welwitschia mirabilis*.

### 1.6.1.6 Fauna

The Project area is regarded as low in overall (all terrestrial species) diversity while the overall terrestrial endemism on the other hand is moderate to high. An estimated 54 reptile, 5 amphibian, 49 mammal and 130 bird species (breeding residents) are known or expected to occur in the general Project area of which a high proportion are endemics. No invertebrate species, wholly or partially endemic to the area, or populations of particular conservation concern were identified during the field surveys. However, they are expected to occur in the area.

For personal use only

## Annexure A (continued)

Tumas Project  
Definitive Feasibility Study Report – Addendum 1  
Chapter 1 – Executive Summary



### 1.6.1.7 Ecological Sensitivity

From an ecological perspective, the highly vegetated patches identified in the Tumas River area are considered the most sensitive due to the complex habitat structure, high persistent productivity and subsequently high level of food and shelter they offer to a range of animals. These areas may also act as refuge areas during prolonged dry periods due to the persistent vegetation and shelter they provide.

These isolated patches allow connectivity along the Tumas River for animal movement and migration (east-west and north-south) and the survival of isolated populations. The remainder of the Tumas River with its major tributaries is also considered sensitive due to the relative high perennial vegetation cover and well-developed structure of the vegetation in the drainage system.

### 1.6.1.8 Air Quality

Dispersion modelling was conducted to identify the main contributing sources to the measured PM<sub>10</sub> and PM<sub>2.5</sub> concentrations in the Project area. Modelled results indicated that vehicle entrainment from roads are the main contributing sources of PM<sub>10</sub> and PM<sub>2.5</sub> emissions. Windblown dust from natural exposed surfaces at and around the Project area is also regarded to be a significant source of particulate matter emissions under high wind speed conditions (>10 m/s). The average dustfall rates measured in the Project area were between 5 to 22 mg/m<sup>2</sup>/day. An E-sampler measuring the PM<sub>10</sub> dust levels in the Project area recorded values ranged between 0.3 and 64.6 µg/m<sup>3</sup>, which was below the evaluation criteria of 75 µg/m<sup>3</sup>.

Passive samplers measured ambient sulfur dioxide (SO<sub>2</sub>), nitrous dioxide (NO<sub>2</sub>) with the results for the SO<sub>2</sub> and NO<sub>2</sub> showing an annual average below the criteria of 50 µg/m<sup>3</sup> and 40 µg/m<sup>3</sup>, respectively. Volatile Organic Compounds (VOC) concentrations were below detection limit.

### 1.6.1.9 Noise

Results from a baseline noise monitoring survey showed that A-weighted equivalent sound pressure levels over 40 to 60 minutes (LAFeq) ranged between 24.2 dBA and 52.3 dBA. The impulse corrected A-weighted equivalent sound pressure levels (LALeq) ranged between 36.5 dBA and 56.1 dBA. Noise levels which were exceeded 90% of the measurement period, A-weighted and calculated by statistical analysis (LAF90), were between 13.2 dBA and 24.0 dBA.

### 1.6.1.10 Radiological Environment

A radiation dose results from the continuous exposure to ionising radiation from several sources in the natural environment, including highly energetic cosmic rays from the Earth's atmosphere (the cosmic contribution) and from radioactive elements contained in the Earth's crust (the terrestrial contribution). The following radiation-related baseline exposure doses were estimated for the Tumas Project area:

- a total direct external gamma exposure dose of some 1.1 ± 0.4 mSv/y;
- an inhalation dose due to radon and progeny of some 0.2 ± 0.1 mSv/y; and
- an inhalation dose due to ambient atmospheric dust of some 0.003 mSv/y.

For personal use only

# Annexure A (continued)

Tumas Project  
Definitive Feasibility Study Report – Addendum 1  
Chapter 1 – Executive Summary



## 1.6.1.11 Archaeology

There were 48 archaeological sites recorded in the Project area, 23 of which are seed diggings and 16 sites indicating human settlement, including a single basecamp site and five outpost sites where people may have rested during seed gathering excursions.

## 1.6.1.12 Social Setting

The Erongo Region is the second most prosperous region in Namibia, with 70% of the available labour force employed. The coastal towns of Walvis Bay and Swakopmund have attracted migrants from all over the country and have experienced high annual growth rates of between 4.7% - 5.3% since 2001. This has led to an increase of impoverished shacks in which approximately 40% of the population of Walvis Bay and Swakopmund dwell.

Around 400 #Aonin Topnaar people live along the Kuiseb River in 14 communities. The communities mainly depend on small-scale livestock production of goats, cattle and donkeys, and government pensions as they are no longer allowed wildlife offtake from their former hunting grounds in the NNNP.

## 1.6.2 Environmental Impact Assessment

An Environmental Impact Assessment (**EIA**) has been conducted for the Tumas Project and the proposed power line and water line. The EIA is based on meeting the requirements of the Namibian Environmental Management Act (Act. No. 7 of 2007) and Section 15(2) of the associated EIA Regulations, as well as supporting policies and guidelines.

The terms of reference for specialist investigations were developed during the Scoping Phase of the EIA. The potential environmental impacts were identified by the team of environmental specialists in consultation with stakeholders. The outcomes of the assessments have been integrated into the EIA. The actions required to effectively implement design requirements, management and mitigation measures and monitoring requirements are detailed in an Environmental Management Plan (**EMP**).

### 1.6.2.1 Ecological System

An assessment of the overall ecological biodiversity of the Project area and impact of the Project was undertaken. The ecological biodiversity assessment integrated the potential impacts on plants, vertebrate fauna, invertebrates and the surface hydrological environment to determine impacts of the ecological processes and functions in the Project area. The proposed mitigation measures to address potential impacts on the ecological system include the following:

- delay the mining in the resource areas overlapping with ecologically sensitive areas until further research and monitoring has been undertaken;
- maintain surface flow in drainage lines as far as is practicable;
- minimise the footprint of disturbed areas as far as possible;
- minimise damage or destruction to the dense vegetation areas, trees and large shrubs;

For personal use only

## Annexure A (continued)

- progressively restore the drainage system after mining in that area has been completed;
- locate service roads and other infrastructure outside of the river drainage lines;
- minimise disturbances on the southern side of the river to allow larger animals to move around disturbances;
- strip the top alluvial material in drainage areas that are to be mined and store separately;
- backfill mining pits and cover with the stored alluvial material;
- monitor the effect of changes in water and dust on sensitive areas and flora; and
- install stormwater management measures and infrastructure to prevent dirty water from entering the clean water systems.

### 1.6.2.2 Groundwater

Seepage from the tailings and waste rock dumps into underlying aquifers may have an impact on rising groundwater levels and groundwater quality. A geochemical study was conducted to predict the prevalent metals' initial concentration and their interaction with ground and rainwater. The geochemical modelling concluded that the uranium leachate from tailings and waste rock's reaction with rain and groundwater will revert to background values of 0.05-0.2 ppm. The non-reactive transport model produced predicted that the pollution plume will not migrate outside the mining licence area, even for a 100-year period.

The waste rock was also geochemically assessed and was found to be non-acid forming with a very high neutralising capacity. The geochemical study showed that when waste rock leachate reacts incrementally with groundwater, the concentrations of uranium will approach levels close to 0.1 ppm, which is the background concentration in the groundwater.

The management measures proposed to mitigate or minimise the impacts of the Project on the groundwater level and quality include:

- applying monitoring data to determine changes in groundwater levels;
- designing the process plant to maximise the recovery and recycling of process liquor;
- monitoring U and V concentration in the tailings;
- allowing the tailings to dry, cover with waste rock and contour the Tailings Storage Facility (**TSF**) to minimise erosion;
- allow for enough freeboard to prevent phreatic surface in the backfilled tailings to reach surface or the level of the shallow alluvium;
- collecting and recycling tailing seepage back to the process water pond;
- developing numerical groundwater focus models for individual mining areas/ tailings facilities; and
- conducting continuous groundwater monitoring.

## Annexure A (continued)

Tumas Project  
Definitive Feasibility Study Report – Addendum 1  
Chapter 1 – Executive Summary



### 1.6.2.3 Air Quality

An air quality impact assessment was conducted for the Project. Two mining scenarios were assessed for the operational phases to determine the potential worst-case air quality impacts, which were based on the maximum mining rates and maximum hauling distances.

The key management measures to be implemented to minimise air quality impacts include:

- the use of chemical surfactants on unpaved roads to control vehicle-entrained dust;
- the application of water sprays to control dust from crushing and screening operations and at material transfer points; and
- ongoing air quality monitoring.

### 1.6.2.4 Radiological Impacts

Potential radiological impacts occur through various pathways, including external exposure to gamma radiation due to the presence of radionuclides in Naturally Occurring Radioactive Material (**NORM**) and internal exposure to radiation, via the atmospheric and aquatic pathways. The radiological impact assessment found that all public radiation exposure doses resulting from uranium mining and processing operations at the Project will be trivial exposure doses as they result in total exposure doses of less than 1  $\mu\text{Sv/y}$  for adults and for infant receptors.

The mitigations for minimising radiological dose impacts include:

- implementing active and passive dust suppression measures;
- minimising seepage and related unintended releases of radiologically relevant minerals, liquids and gases;
- disposing of radioactive contaminated waste onto Waste Rock Dumps (**WRDs**) and TSF in an acceptable manner;
- commencing rehabilitation and closure planning early; and
- planning and implementing design and monitoring provisions for WRDs and TSFs.

### 1.6.2.5 Noise

A noise modelling study and assessment was conducted applying the baseline conditions and the predicted noise levels from the Project activities. The key mitigation measures proposed to be implemented for noise attenuation and management include:

- maintaining a noise complaint register;
- monitoring ongoing noise level;
- communicating blast schedules to relevant interested and affected parties; and
- reassessing changes to the mine plan and operations on the noise impact of the Project.

For personal use only

## Annexure A (continued)

Tumas Project  
Definitive Feasibility Study Report – Addendum 1  
Chapter 1 – Executive Summary



### 1.6.2.6 Archaeology

The main issue concerning the impact of the Project activities on the cultural heritage resources is the disturbance or destruction of the archaeological sites and their landscape setting.

The measures to mitigate impacts on the key archaeological sites in the Project area include:

- modifying/rerouting of the Project infrastructure layout; and
- potential excavation and mapping of sites to recover material for dating.

### 1.6.2.7 Visual

The most significant components of the Project from a visual impact perspective are the WRDs, process plant, solar power plant, open pits and other associated major infrastructure. The mitigation measures to be implemented to minimise the visual impacts include the following:

- land disturbance will be limited to what is only necessary;
- the structures remaining after closure will be shaped to blend with the surrounding landscape; and
- light fixtures will be only the bare minimum required and will be directed to reduce light spillage.

### 1.6.2.8 Socio- Economic

A socio-economic impact assessment was conducted as part of the EIA process. The Project's construction and operational phase will result in positive direct, indirect and induced economic impacts to the local, regional and national economy. The Project will have positive impacts on job creation and skills development through the creation of ~507 direct jobs and a further ~1,900 – 2,550 indirect jobs. Walvis Bay and Swakopmund will experience some Project-induced in-migration.

Overall, the economic benefits and the jobs and skills created far outweigh the risks that may come with in-migration of jobseekers, which can be mitigated under committed management.

## 1.7 Geology and Mineral Resource

### 1.7.1 Geological Setting and Mineralisation

Surficial uranium deposits occur on the coastal plain of the Namib Desert, mainly between the Great Escarpment in the east and the coast in the west. The deposits are associated with fluvial environments within palaeovalleys of ancient rivers that flowed westwards from the Great Escarpment during Upper Cretaceous and Lower Tertiary time (88 to 25 million years ago).

Uranium mineralisation occurs as carnotite (secondary uranium-vanadium mineral), hosted by Tertiary and Quaternary fluvial sediments occupying narrow and steep-sided palaeochannels (refer Figure 2). Host rocks vary from hard, carbonate-cemented sandstones and conglomerates (calcrete) to poorly consolidated and friable sands. The Tumas Project is comprised of a series of palaeochannel/calcrete-type uranium deposits totalling 137 Mlb  $U_3O_8$ .

For personal use only

# Annexure A (continued)

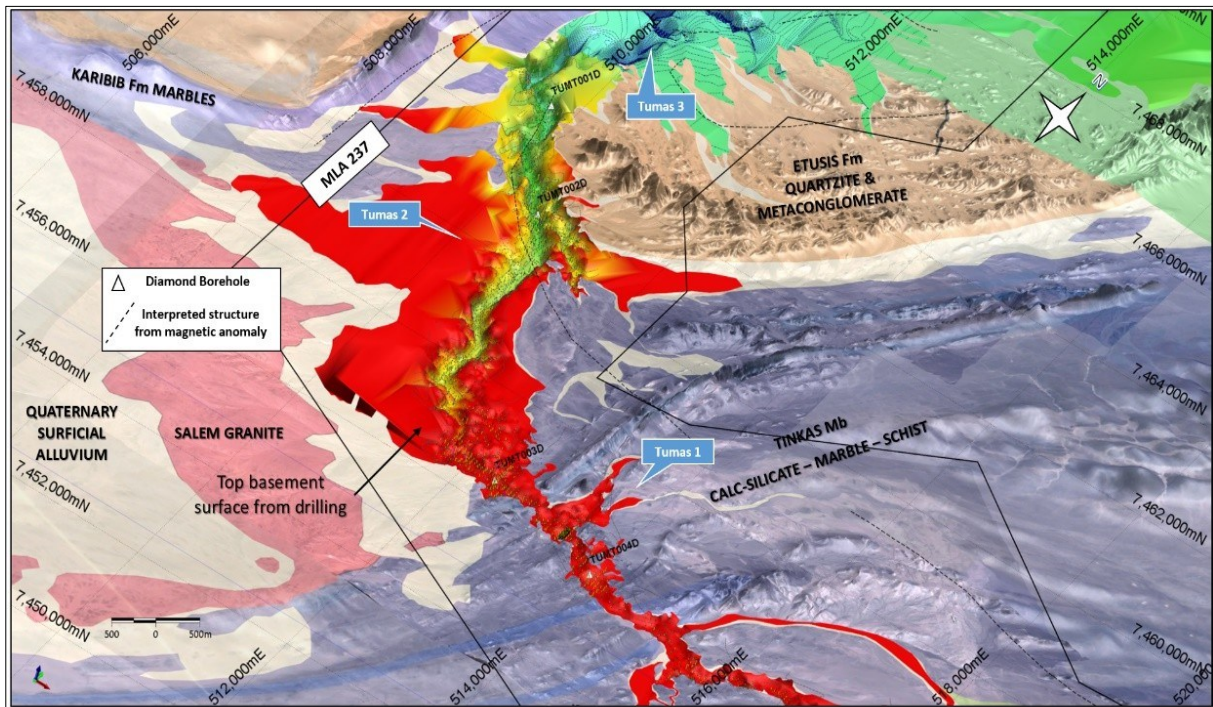

**Figure 2: 3D View of Tumas 1 and Tumas 2 Deposits.**

## 1.7.2 Drilling

Table 1 summarises the drilling undertaken at the Tumas Project since 2007.

**Table 1: Tumas Project Drilling Summary.**

Year	Reverse Circulation		Diamond		Aircore	
	Holes	Metres	Holes	Metres	Holes	Metres
Tumas 1 East	4,597	54,228	5	74	6	44
Tumas 1 and Tumas 2	2,634	62,306	2	62	0	0
Tumas 3	4,820	106,923	21	451.8	3	75
Tubas	1,524	31,745	8	157.3	713	8,876
<b>Total</b>	<b>13,575</b>	<b>255,202</b>	<b>36</b>	<b>745.1</b>	<b>722</b>	<b>8,995</b>

## 1.7.3 Sample Preparation and Analysis

Table 1 indicates that reverse circulation (RC) was the primary drilling method for the Tumas Project, with most holes sampled at 1 m intervals and each hole having a downhole gamma log survey carried out immediately after drilling was completed. All samples are lithologically logged on site and a portable RadEye™ scintillometer used to determine the radioactivity level of each sampled interval.

Assaying for the Tubas, Tumas 1 and Tumas 2 deposits was predominantly completed at the RUN in-house laboratory in Swakopmund using loose powder X-ray fluorescence (XRF) techniques with some check assays completed by the ALS laboratory in Perth, Australia using a combination of pressed powder XRF and inductively coupled plasma mass spectrometry (ICP-MS) techniques.

For personal use only

## Annexure A (continued)

Tumas Project  
Definitive Feasibility Study Report – Addendum 1  
Chapter 1 – Executive Summary



Calibrated lead block scintillometer measurements were used for a limited number of samples within the Tumas 2 dataset. Assays on drilling at Tumas 1 East completed after 2016 were undertaken on drill chips at the RMR in-house laboratory using portable XRF (pXRF) instruments with some check assays completed by ALS in Johannesburg, South Africa using pressed powder XRF techniques.

The early assaying for the Tumas 3 deposit was completed at the RUN laboratory in Swakopmund using loose powder XRF techniques, with some check assays completed by the ALS laboratory in Perth, Australia using a combination of pressed powder and ICP-MS techniques. Assays on drilling at Tumas 3 completed after 2016 were undertaken on drill chips at the RMR in-house laboratory using pXRF instruments with some check assays completed by ALS in Johannesburg, South Africa using pressed powder XRF techniques.

### 1.7.4 Data Verification

Drilling data, comprising collar locations, downhole surveys, geological logging, assays and downhole logging results are stored in an externally hosted third-party database. Data is validated by a specialist database geologist and internal database consistency checks. All data is referenced to the original logs, assay certificates and downhole logging files with internal audit trails maintained within the database.

Downhole gamma files are processed into the database using internal routines to derive an equivalent uranium value (an external geophysical consultant has validated this methodology). Calibration values for the generation of the equivalent uranium values are maintained within the database and provide an audit trail for factors applied to downhole radiometric logging results.

Downhole gamma values are composited to 1 m intervals, from original 5 cm data, within the database and are exported as required for geological interpretation and mineral resource estimation work. The composited gamma values are also compared to geochemical assays for similar intervals to validate further the dataset derived from downhole wireline logging. No significant disequilibrium has been identified within the geophysical dataset and, as none was detected along 40 km of palaeochannel, none is expected to be present. Consistency checks against the original files and paper logs were undertaken to confirm the validity of the imported data during the import of the geological data into the most recent database.

### 1.7.5 Geological Interpretation

All uranium mineralisation within the Tumas deposits is secondary in nature (carnotite) and is hosted by calcretised channel fill sediments of late Tertiary to Quaternary age. The palaeochannel sediments are mainly composed of poorly sorted polymictic gravels and conglomerates which locally turn to be clayey and/or silty with minor sands and silts. Fine-grained calcite-cemented sandstone occurs locally at the bottom and bottom edges of the palaeochannel. The detrital components consist mainly of sub-angular quartz and feldspar granules with abundant debris of surrounding basement rocks, e.g., mica schists, meta-quartzites, and granites. Calcrete bodies are interbedded with porous gravel units throughout the sedimentary column.

For personal use only

## Annexure A (continued)

Tumas Project  
Definitive Feasibility Study Report – Addendum 1  
Chapter 1 – Executive Summary



Two main types of calcretes are observed. One is pale to dark brown and hard, the other is white-whitish and commonly chalky. Other minor types are darker, like a dark reddish brown to pale red, very hard, fine-grained calcrete.

Preferential precipitation of carnotite is linked to physical barriers at basement levels, which were mapped by the drilling, constricting the groundwater flows and chemical barriers occurring where bedrock marble is in contact with the sediment fill.

The mineralisation considered in this study is divided from East to West into the Tumas 1 East, Tumas 1, Tumas 2 and Tumas 3 orebodies. The Tumas 1 East deposit is located in the most easterly part of the Tumas palaeochannel. It varies in width from a narrow 100 m to 400 m and increases in depth from east to west from 10 m to 20 m. It includes tributary channels to the north and south of the main channel. Mineralisation is occurring from surface to the channel base.

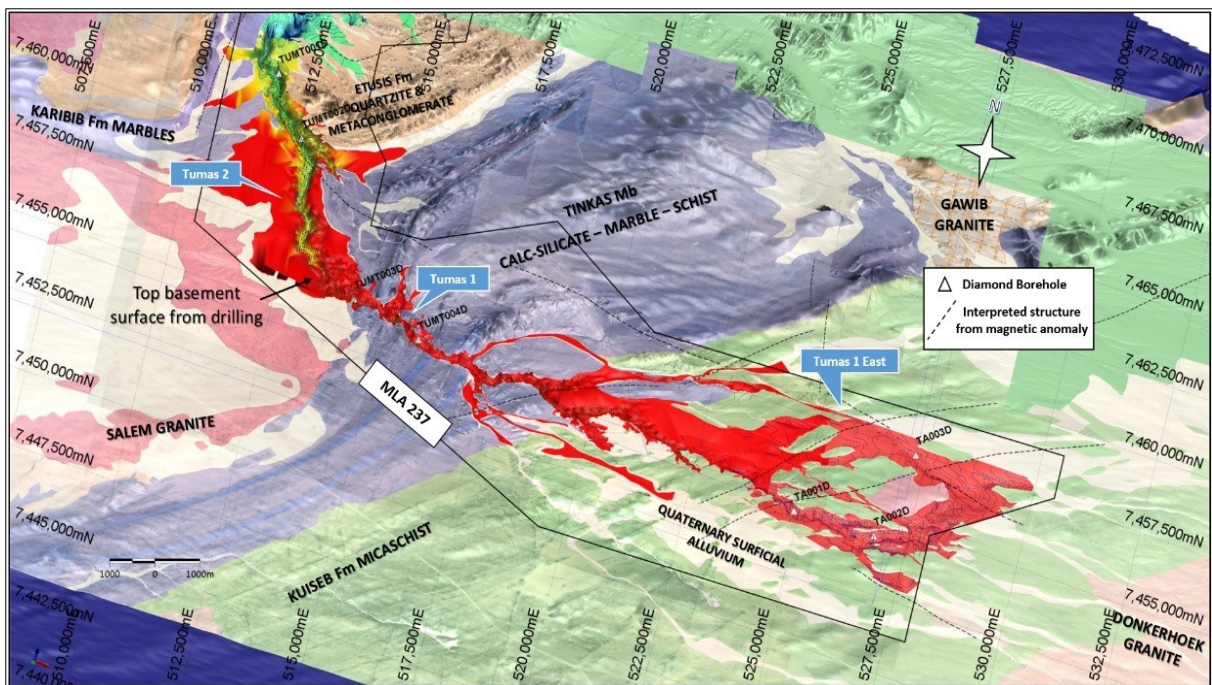

**Figure 3: Oblique View of Tumas 1 East in Relation to Tumas 1 and Tumas 2 Deposits.**

The Tumas palaeochannel Zone 1 is relatively shallow and narrow, up to a maximum of 15 m to 20 m depth and up to 200 m wide. The zone sits directly west of the Tumas 1 East zone. It continues westwards, cuts through the north-east striking Tinkas Formation and bends to the north into the Tumas 2 zone. Two mineralised fining up sequences are observed whereby higher-grade mineralisation occurs at the transition zone between the lower cross-stratified coarser and locally calcretised deposits and an overlying planar horizontal laminated silty sandy grit.

Further downstream, at the southern end of Tumas 2, the Tumas palaeochannel turns to a north-northwesterly direction and its depth gradually increases to slightly over 40 m towards the northern end of Tumas 2. The north-northwesterly trending Tumas 2 palaeochannel is 200 to 500 m wide. The +100 ppm  $eU_3O_8$  mineralisation is generally patchier than at Tumas 1 and 3.

## Annexure A (continued)

Tumas Project  
Definitive Feasibility Study Report – Addendum 1  
Chapter 1 – Executive Summary



At Tumas 2, the 15 m thick upper sequence is moderate reddish to light brown in colour and consists of crudely stratified, less calcareous and more oxidised deposits. The base of the sequence comprises calcite-cemented and matrix-supported sandy conglomerates and grits with abundant angular to subangular clasts of the surrounding bedrock (i.e., mica-schist, quartzite) and lenses of silty to sandy grit. The top of the sequence consists predominantly of planar horizontal laminated silty to clayey sand which locally can be gritty. Higher grade uranium mineralisation occurs at the contact zone of the upper and lower sequence.

At Tumas 3 the palaeochannel turns into a west-north-westerly direction. Here sediments include 40 to 60 m of palaeochannel fill deposited over the so-called Namib Unconformity Surface. This palaeosurface is characterised by partially steep incised palaeochannels, deeply carved into the folded and metamorphosed Damara sequence. The palaeochannel can reach up to 1.5 km wide. Mineralised tributaries enter the main palaeochannel from the east and south.

The Tumas 3 orebody is characterised by at least two sedimentary cycles overlying each other. The fining-upward sequences are composed of coarse conglomerates at the bottom, especially at the bedrock contacts followed by gravels and sand and clays with calcrete layers developed towards their tops.

Uranium mineralisation is confined to calcrete layers in both cycles. Uranium is precipitated as carnotite close to the palaeochannel floor and edges at the contact to the Proterozoic bedrock and sporadically occurs in more silty gravels of the upper sequence below the upper calcrete.

In general, higher uranium grades seem to be linked to areas of confluencing sub-channels, where they preferentially occur above island channel-bars and flood plains at the palaeochannel sides. The top calcrete unit hosts the main deposit extending across those basement islands.

### 1.7.6 Mineral Resource Estimation

The Tubas, Tumas 1 East and Tumas 3 resources have been estimated using Multi Indicator Kriging (MIK) methods. The exploration dataset was split into ore and waste domains and indicator variography used to enable the correct assessment of the variance adjustment to be applied to the MIK estimate for each domain. In all cases the short range variography was dominated by the downhole direction as this contained both the best continuity and shortest sample spacing with continuity and ranges in the X and Y directions being dominated by drill hole spacing and general mineralisation continuity throughout the deposit.

Panel sizes used in the estimation of the mineral resource were set at 50 m x 50 m x 3 m for Tumas 1 East and Tumas 3. These were deemed appropriate to the sample spacing of the underlying dataset in conjunction with the thickness of the mineralisation. Final panel sizes for Tumas 1 and Tumas 2 were set at 50 m x 50 m x 2 m as the mineralisation is generally thinner in these deposits. For the Tubas deposit, a panel size of 40 m x 40 m x 2 m was selected. As an MIK estimate was being undertaken, the expected Selective Mining Unit (SMU) size was set at 4 m x 4 m x 3 m or 4 m x 4 m x 2 m as appropriate (similar to that employed at the nearby Langer Heinrich Uranium Mine (LHUM)) for the Tumas deposits and 5 m x 5 m x 2 m for the Tubas deposit with an expected grade control spacing of 4 m x 4 m x 1 m being completed prior to actual mining.

# Annexure A (continued)

Tumas Project  
 Definitive Feasibility Study Report – Addendum 1  
 Chapter 1 – Executive Summary

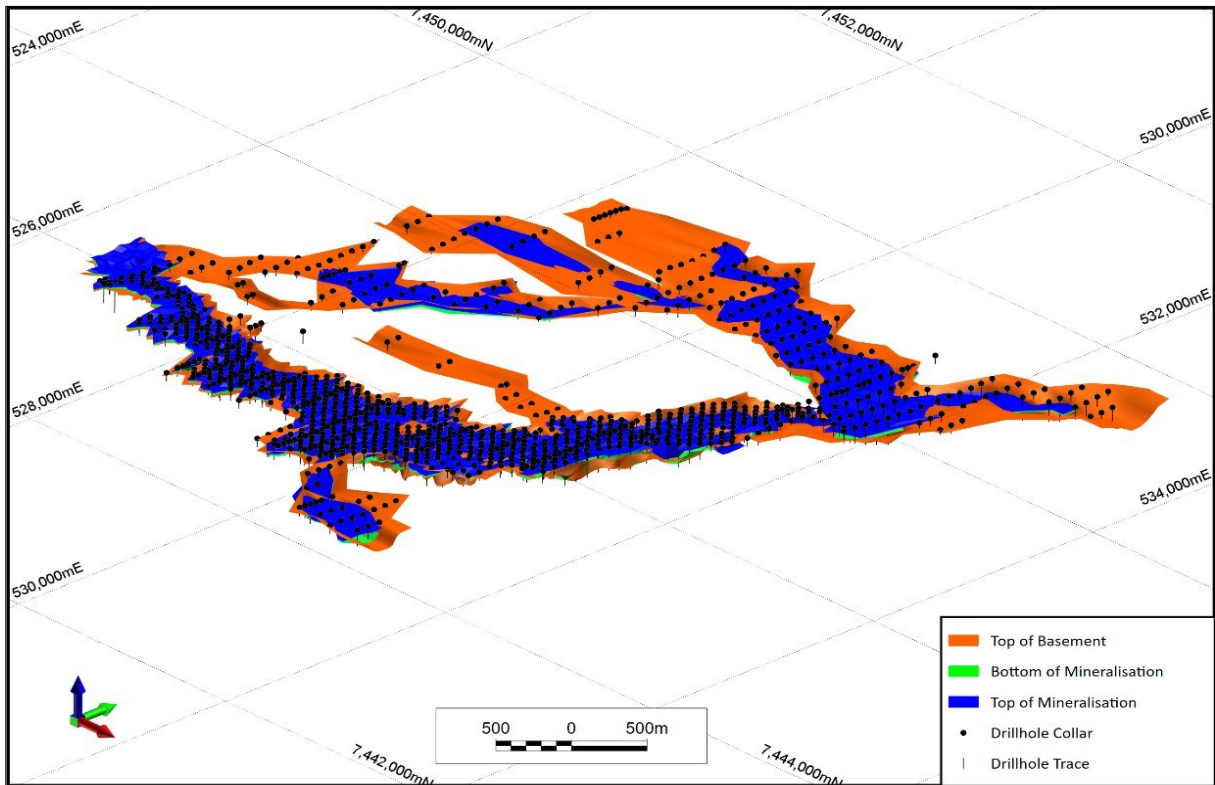

**Figure 4: Tumas 1 East Wireframes, Oblique View.**

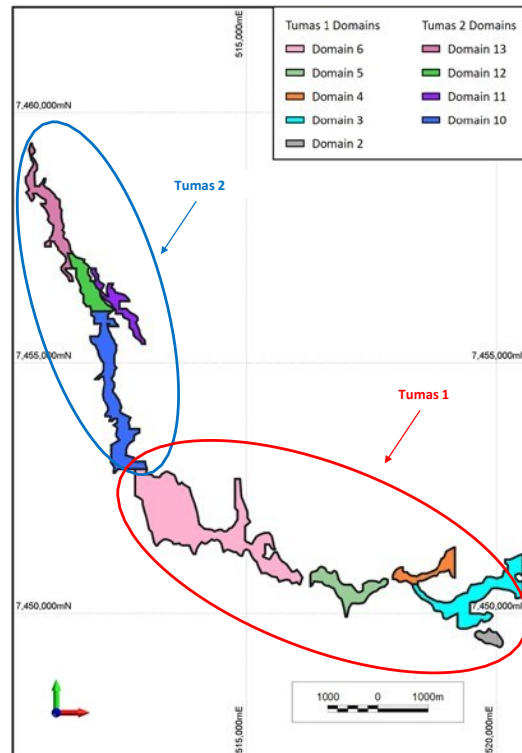

**Figure 5: Tumas 1 and Tumas 2 Mineralised Domains, Plan View.**

For personal use only

# Annexure A (continued)

Tumas Project  
Definitive Feasibility Study Report – Addendum 1  
Chapter 1 – Executive Summary

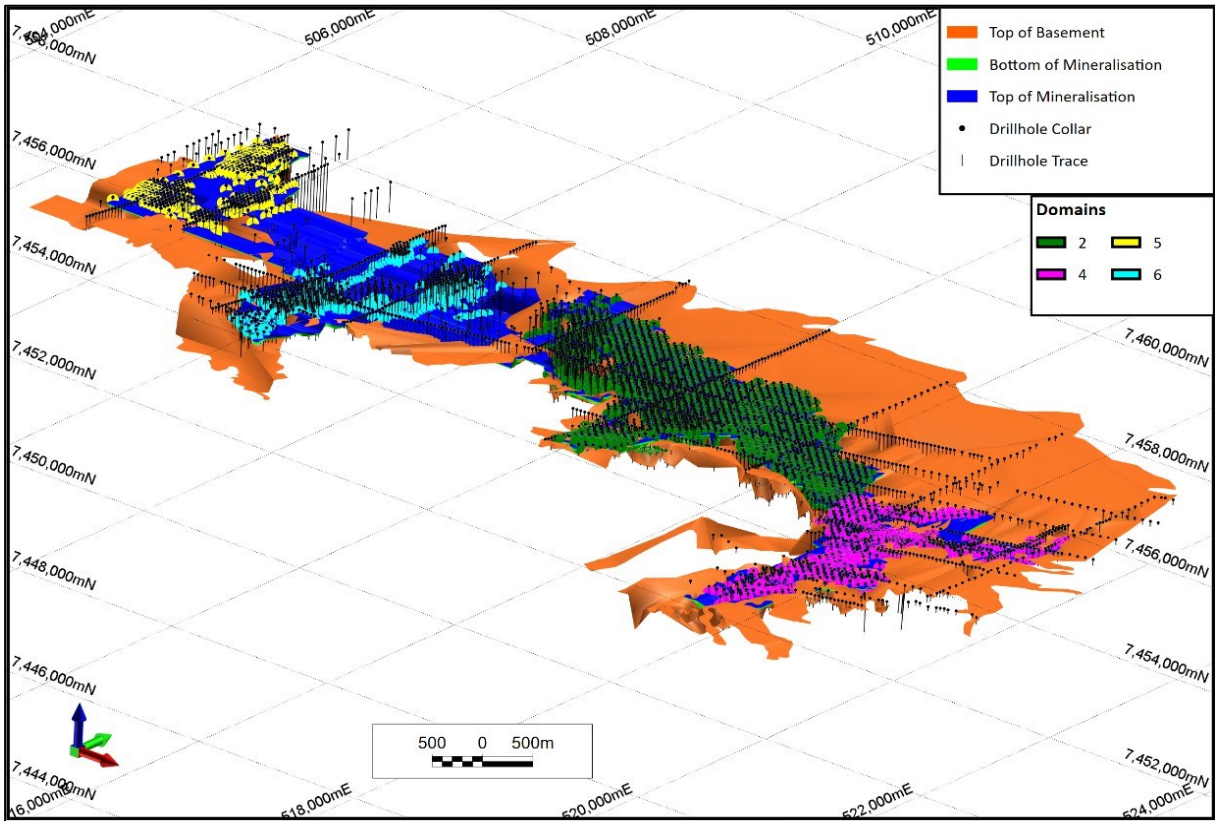

Figure 6: Tumas 3 Wireframes, Oblique View.

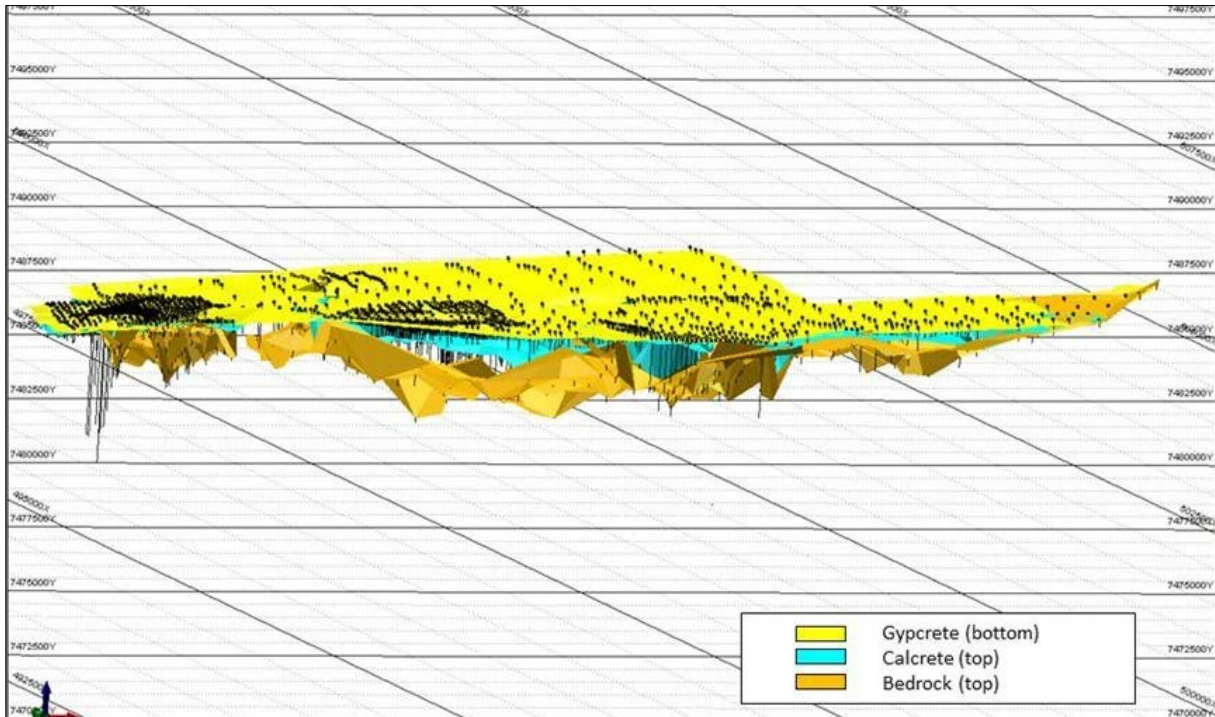

Figure 7: Tubas Wireframes, Oblique View.

For personal use only

# Annexure A (continued)

Tumas Project  
Definitive Feasibility Study Report – Addendum 1  
Chapter 1 – Executive Summary



## 1.7.7 Mineral Resource Estimate

The Tumas Project Mineral Resource documented in Table 2 has been classified as Indicated and Inferred Resources and reported in accordance with the 2012 JORC Code for all deposits except Tubas, which is reported in accordance with the 2004 JORC Code.

**Table 2: Tumas Project Mineral Resources at 100 ppm U<sub>3</sub>O<sub>8</sub> Cut-off.**

Deposit	JORC Class	Cut-off	Tonnes	U <sub>3</sub> O <sub>8</sub> ppm	U <sub>3</sub> O <sub>8</sub> (t)	U <sub>3</sub> O <sub>8</sub> (Mlb)	U <sub>3</sub> O <sub>8</sub> (Mlb)		
							Meas.	Ind.	Inf.
Tumas 3	Measured	100	33.8	300	10,210	22.5	22.5		
	Indicated	100	48.6	335	16,200	35.7		35.7	
	Inferred	100	16.1	170	2,770	6.1			6.1
<b>Tumas 3 Total</b>			<b>98.5</b>	<b>295</b>	<b>29,180</b>	<b>64.3</b>			
Tumas 1 & 2	Measured	100	35.2	205	7,270	16.0	16.0		
	Indicated	100	18.9	200	3,760	8.3		8.3	
	Inferred	100	1.8	190	340	0.7			0.7
<b>Tumas 1 &amp; 2 Total</b>			<b>55.9</b>	<b>205</b>	<b>11,370</b>	<b>25.1</b>			
Tumas 1, 2 & 3	Measured	100					0.0		
	Indicated	100	103.8	330	28,830	63.6		63.6	
	Inferred	100	37.3	199	7,300	16.0			16.0
<b>Tumas 1, 2 &amp; 3 Total</b>			<b>210.1</b>	<b>255</b>	<b>53,610</b>	<b>118.1</b>	<b>38.5</b>	<b>63.6</b>	<b>16.0</b>
Tubas Calcrete	Inferred	100	7.4	375	2,765	6.1			6.1
Tubas Sand	Indicated	100	10.0	185	1,900	4.1		4.1	
	Inferred	100	24.0	165	3,900	8.6			8.6
<b>Tubas Total</b>		<b>100</b>	<b>41.4</b>	<b>235</b>	<b>8,565</b>	<b>18.8</b>		<b>4.1</b>	<b>14.7</b>
<b>Tumas 1, 2, 3 &amp; Tubas Project Total</b>			<b>251.5</b>	<b>250</b>	<b>62,175</b>	<b>137</b>	<b>38.5</b>	<b>67.7</b>	<b>30.7</b>

## 1.8 Mining and Ore Reserves

### 1.8.1 Mine Design Considerations

The mining methodology of using conventional excavators and haul trucks is based on the successful application of this methodology in nearby operations of the same configuration (e.g., LHUM).

Geotechnical drilling and assessment has been undertaken for the Project. The design overall pit slope angle of 35° is considered reasonable based on the geotechnical work, relevant experience at other (nearby) locations.

As the palaeochannel aquifer predominantly lies below the ore reserve, no significant pit dewatering is required. Several bores are installed to produce low grade, high total dissolved solids (TDS) water for dust suppression purposes.

For personal use only

## Annexure A (continued)

Tumas Project  
Definitive Feasibility Study Report – Addendum 1  
Chapter 1 – Executive Summary



### 1.8.2 Pit Optimisation

The pit optimisation parameters used reflect the findings of the DFS and are summarised in Table 3. Whilst some of these costs vary from those generated in this study, the findings of the financial modelling presented within this report confirm that the Reserves may be economically exploited.

**Table 3: Mineral Resource Optimisation Input Parameters.**

Parameter	Units	Value	
		Ore	Waste
<b>Mining</b>			
Fuel <sup>1</sup>	\$/bcm	0.78 – 0.96	0.78 – 0.95
Load and haul – in-pit	\$/bcm	1.87 – 2.42	
Haul – ex-pit <sup>1</sup>	\$/bcm	0.92	0.90
Drill and blast	\$/bcm	1.31	
<b>Ore Processing</b>			
U <sub>3</sub> O <sub>8</sub> recovery	%	93.0	
Mining	\$/t ore	2.59	
Processing	\$/t ore	11.31	
Maintenance	\$/t ore	2.04	
C&A	\$/t ore	1.18	
SHR	\$/t ore	0.18	
Environment	\$/t ore	0.06	
HR	\$/t ore	0.02	
Corporate and Marketing	\$/t ore	0.71	
<b>Financial</b>			
U <sub>3</sub> O <sub>8</sub> price	\$/lb U <sub>3</sub> O <sub>8</sub>	100	
Selling costs	\$/lb U <sub>3</sub> O <sub>8</sub>	1.00	
Diesel cost	\$/L	1.04	

<sup>1</sup> costs vary with pit depth.

The result of the pit optimisation runs for Tumas 3 are illustrated in Figure 8, with Shell 36 being selected as the preferred option as it satisfies the company's strategic objectives while remaining a robust shell selection at reduced revenue price assumptions.

# Annexure A (continued)

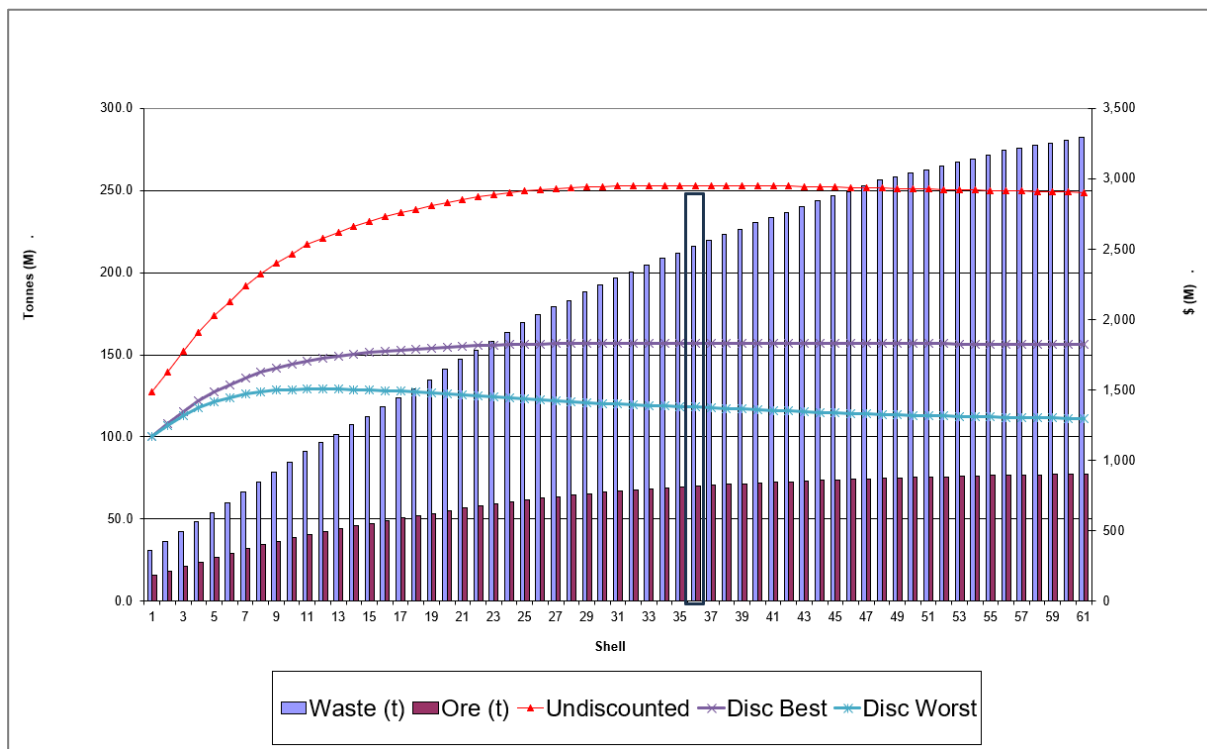

Figure 8: Tumas 3 Tonnage/Cashflow Chart.

### 1.8.3 Waste Rock Characterisation

The mineralogical and chemical analysis of Tumas waste rock samples indicate that the acid-forming potential of the waste rocks is extremely low.

### 1.8.4 Waste Rock Management

As all process plant tailings (including tailings from Tumas 1, Tumas 1 East and Tumas 2) are to be stored within the Tumas 3 pits, the waste rock management process at Tumas 3 differs from that at the other pits.

At Tumas 1, Tumas 1 East and Tumas 2 all waste, other than that required to generate the start-up pit, is direct placed back into a mined-out void and hence will always be below pre-mining topography.

Waste rock from Tumas 3 is either used to construct in-pit divider embankments as part of the tailings management process, placed on ex-pit waste dumps or used as capping on any tailings areas that have been filled to design capacity.

Waste rock mined from the Tumas 3 area not required for divider embankment construction or for final capping is stored permanently in WRD's located at the periphery of the mine pit(s). Waste rock is placed in 10 m lifts with 10 m wide berms. Mineralised waste rock (less than 100 ppm  $U_3O_8$ ) will be encapsulated in the WRD's by non-mineralised waste rock (below detection limit).

For personal use only

## Annexure A (continued)

Tumas Project  
Definitive Feasibility Study Report – Addendum 1  
Chapter 1 – Executive Summary



On completion, each lift is battered below the natural angle of repose to 20° and the overall dump batter slope of the completed dump after rehabilitation shall be 17°. The areas reserved for WRDs in the Tumas 3 area are shown in Figure 9.

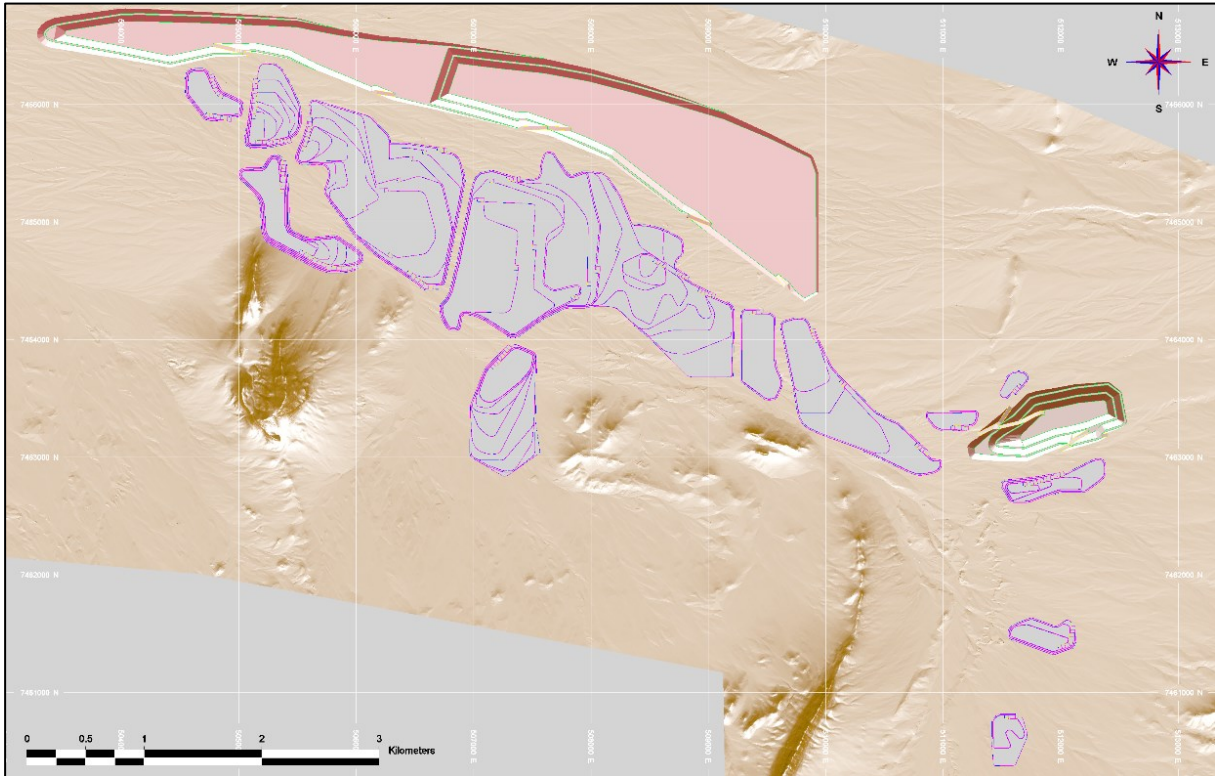

**Figure 9: Tumas 3 WRD Layout.**

### 1.8.5 Mine Production Schedule

The objective of the production schedule was to produce an ore feed within the prescribed design capacity of 4.2 Mt/y with sufficient grade to achieve a final product of 3.6 Mlb U<sub>3</sub>O<sub>8</sub>/y.

The main driver of the development sequence is the need to completely mine out pits so that they can be used as tailings storage facilities.

Mining starts in Tumas 3 before moving to Tumas 1 East followed by Tumas 1 and then finally Tumas 2 as shown in Figure 10. The pit stage mining sequence for Tumas 3 is shown in Figure 10. The smaller stages on the East side of Tumas 3 are mined initially with P3\_P1A\_S1 before moving to P3\_P2\_S1 and then going to the western end of T3 and then generally progressing back to the East.

The schedule achieves the primary aim of producing the target of 3.6 Mlb/y of U<sub>3</sub>O<sub>8</sub> product through Y10, excluding the mill ramp-up. Given the grade processed during those years, the mill capacity is not reached with the amount of U<sub>3</sub>O<sub>8</sub> product acting as a limit. From Y11 onwards the mill feed grade drops, and the 4.2 Mt/y mill capacity becomes the limit, as shown in Figure 10. The feed tonnes and grades are managed by use of planned High-grade ore, Low-grade ore and High Sulfur stockpiling and reclaiming. The production schedule is shown in Figure 9 and Figure 10.

# Annexure A (continued)

Tumas Project  
 Definitive Feasibility Study Report – Addendum 1  
 Chapter 1 – Executive Summary

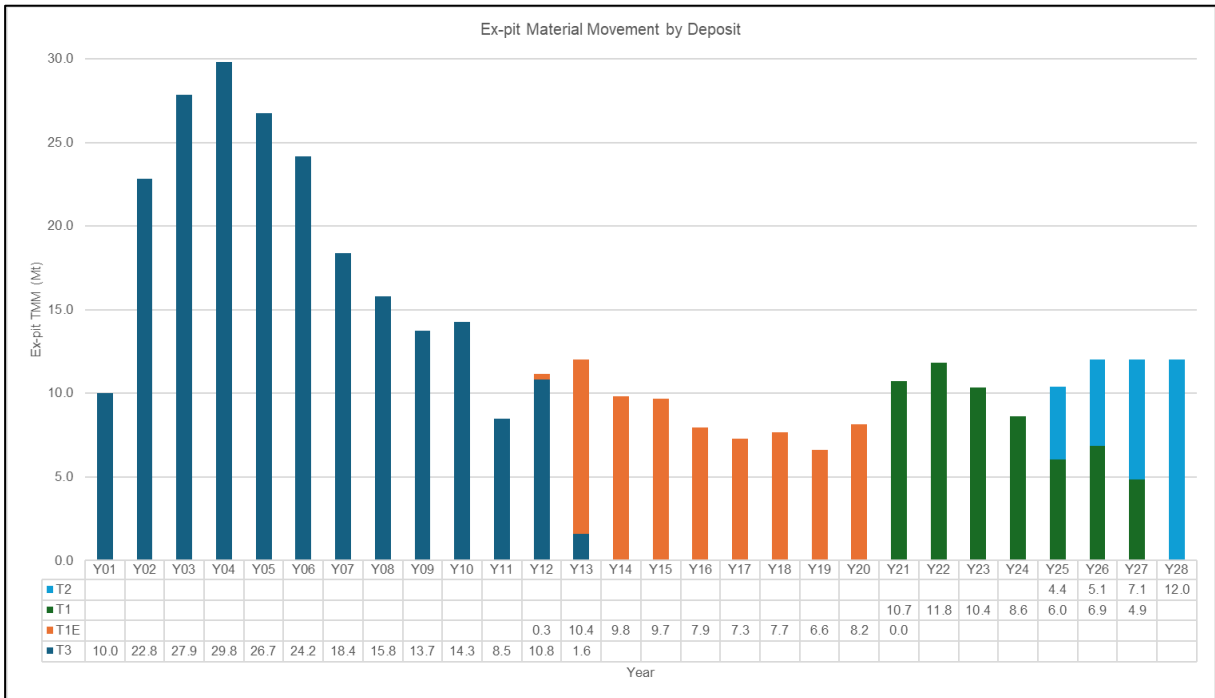

Figure 10: Ex-pit Material Movement by Deposit.

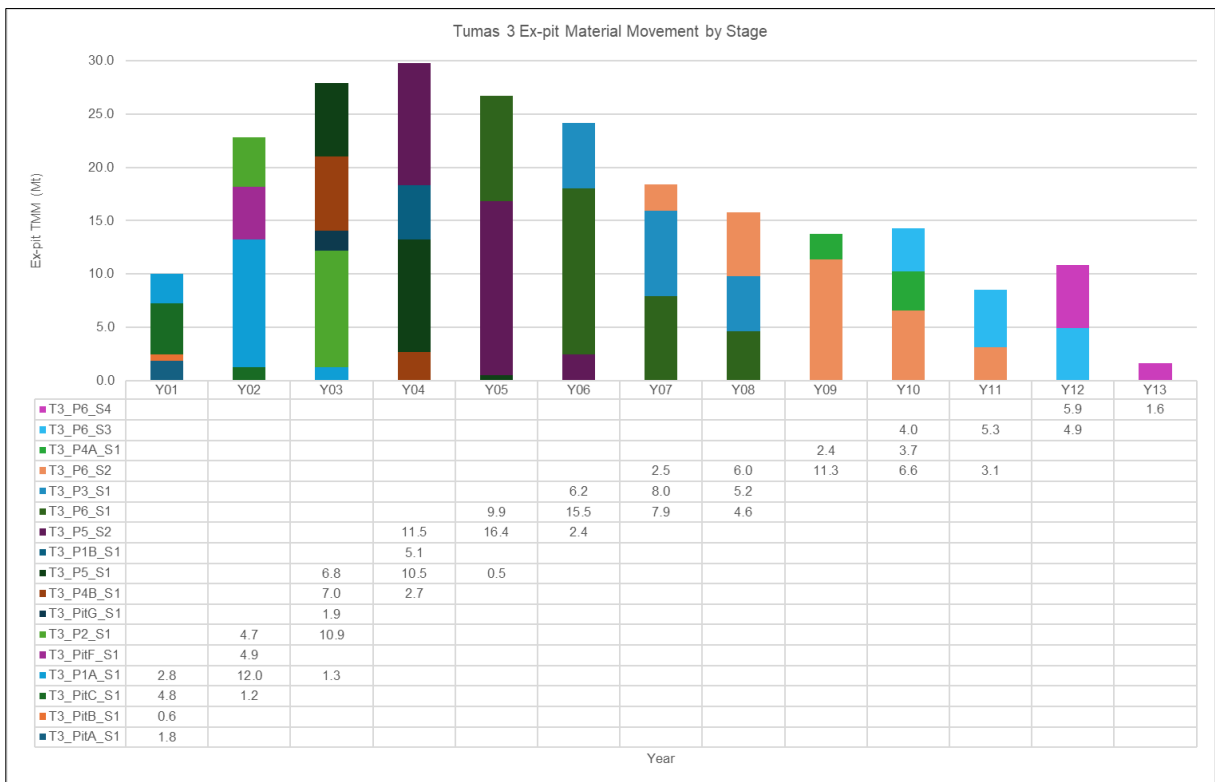

Figure 11: Tumas 3 Ex-pit Material Movement by Stage

For personal use only

# Annexure A (continued)

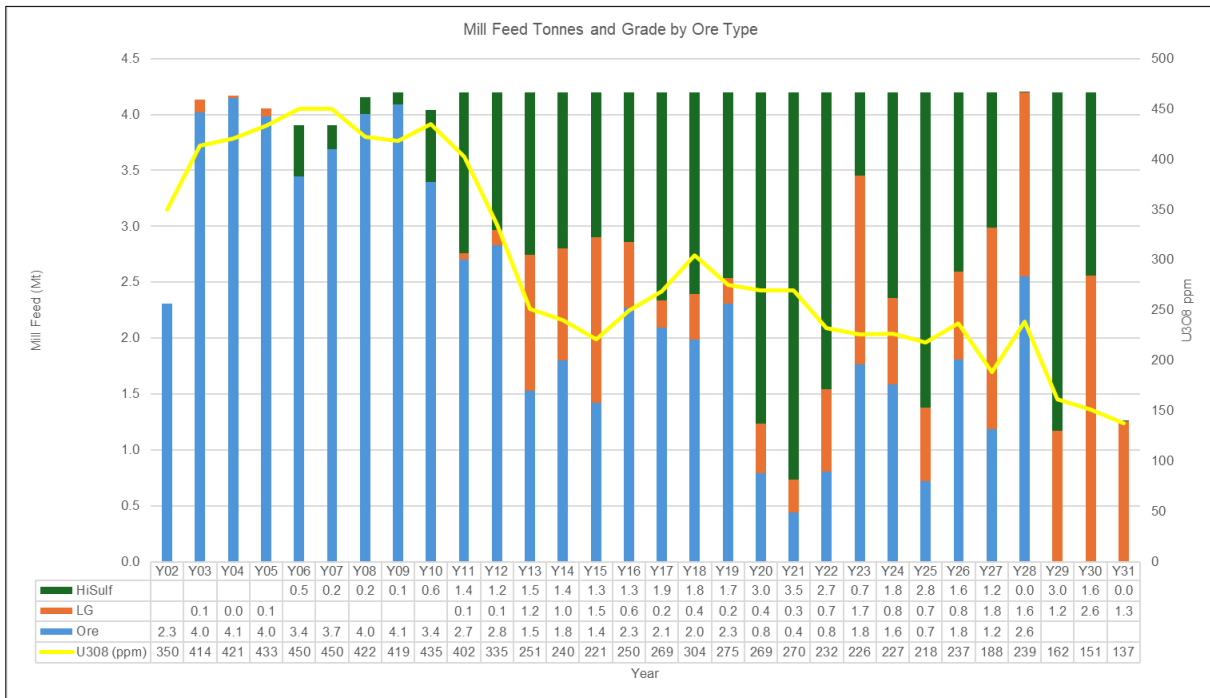

Figure 12: Mill Feed Tonnes and Grade by Ore Type.

### 1.8.6 Mine Contractor, Equipment and Facilities

Towards the end of the DFS period, expressions of interest were sent to seven potential pre-qualified mining contract service providers and subsequent to that, tender documents were provided to five separate groups. The bids received were all largely compliant with the bid requirements and offered a range of fleet spreads. Two were relatively high cost and the remaining three were all of a similar magnitude. One of the three, considered to be the most suitable (not the lowest cost) was selected to develop the mining cost estimate for the Project.

The key equipment selection of the selected bidder is listed in Table 4.

Table 4: LOM Mining Equipment Requirements.

Description	Proposed Plant	Number
250 t excavator	Caterpillar 6030BH	3
93 t dump truck	Caterpillar 777E	16
12.3 m <sup>3</sup> front end loader	Caterpillar 992K	3
56 t haul truck	Volvo FMX 460 10X4 tipper	25

For personal use only

## Annexure A (continued)

Tumas Project  
Definitive Feasibility Study Report – Addendum 1  
Chapter 1 – Executive Summary



### 1.8.7 Ore Reserves

The Tumas Ore Reserve estimate was updated in December 2024 and is shown in Table 5.

**Table 5: Tumas Ore Reserve Estimate.**

	December 2024 Reserve			
	U <sub>3</sub> O <sub>8</sub> Cut-off ppm	Tonnes Mt	U <sub>3</sub> O <sub>8</sub> ppm	U <sub>3</sub> O <sub>8</sub> Metal Mlb
Tumas 3 Proved	100	21.0	357	16.6
Tumas 3 Probable	100	30.3	398	26.6
<b>Total</b>	<b>100</b>	<b>51.3</b>	<b>381</b>	<b>43.2</b>
Tumas 1 and 2 Proved	100	23.7	227	11.9
Tumas 1 and 2 Probable	100	10.1	238	5.4
<b>Total</b>	<b>100</b>	<b>33.8</b>	<b>230</b>	<b>17.8</b>
Tumas 1 East Proved				
Tumas 1 East Probable	100	35.0	246	19.0
<b>Total</b>	<b>100</b>	<b>35.0</b>	<b>246</b>	<b>19.0</b>
Total Proved	100	44.7	287	28.4
Total Probable	100	75.4	305	50.9
<b>Total</b>	<b>100</b>	<b>120.1</b>	<b>298</b>	<b>79.3</b>

### 1.9 Geometallurgy

Four mineralisation types have been defined within the Tumas-Tubas palaeochannel based on the type of host rock: calcrete, gypcrete, red sand and basement. Of these, the calcrete-type mineralisation contains most of the uranium. The calcrete ranges from sand to granule size, with about 30 % consisting of pebbles with a maximum dimension of 6.4 cm. The only uranium-bearing mineral of economic importance is carnotite ( $K_2(UO_2)_2V_2O_8 \cdot 3(H_2O)$ ), which contains vanadium with a U/V ratio of 4.5. Detailed mineralogical and geochemical analysis shows that vanadium is also contained in iron oxide and titanium minerals. The calcrete-type mineralisation contains on average 3-4 wt% clay with the clays species being illite and palygorskite (magnesium-bearing). Investigations of leach samples show that a small portion of uranium behaves refractorily as it occurs as submicron-sized carnotite inclusions in calcite.

Only gypcrete and sulphate bearing calcrete are known to have direct adverse impacts on the leaching efficiency using alkaline conditions. Gypcrete is defined as palaeochannel sediment with greater than 0.35 wt% total in sulfur (equivalent to 1.58 wt% bassanite, a calcium sulphate mineral). Gypcrete forms a thin, discontinuous layer, a few metres below the surface and generally defines the upper limit of uranium mineralisation. It is only mineralised with uranium in a few locations and is likely to make up only a very small portion of the total resource. Based on the process design, a sulphate sulfur content of 0.035% is the accepted average concentration for ore material, although the plant has been designed to accept 0.1 %. The challenge of determining the boundary between sulfur-rich and sulfur-poor material is still being addressed.

# Annexure A (continued)

Tumas Project  
Definitive Feasibility Study Report – Addendum 1  
Chapter 1 – Executive Summary



## 1.10 Metallurgy

### 1.10.1 Introduction

Given the geological and mineralogical similarities between Tumas and the nearby Langer Heinrich Uranium Mine (**LHUM**), the development of a metallurgical process for Tumas has used LHUM as a starting point, with fundamental process changes made only by exception to improve on the inherent operating cost limitations of the LHUM process.

Beneficiation testwork was undertaken with the objective of achieving a clean physical separation of clast (coarse, barren silicate particles) and cement (fine calcite containing the sole value mineral, carnotite). Specific attention was given to achieving a high degree of cement liberation from the clasts (to permit high uranium recovery) while minimising breakage of the clasts themselves, to maximise mass rejection ahead of the downstream hydrometallurgical plant. No low grade ultra-fine (slimes) fractions were evident and thus desliming was not considered due to the detrimental impact on uranium recovery.

Given the high carbonate and low sulphate content of the fine beneficiation product only alkaline leaching was considered. Testwork was conducted across a range of leach conditions to support a trade-off study; ultimately leach conditions similar to LHUM were selected to optimise process economics.

Pre- and post-leach solid-liquid separation testwork was conducted for both thickening and filtration, with filtration rejected on economics due to low/unfavourable filtration rates. A counter-current decantation (**CCD**) circuit was therefore selected, similar to LHUM.

Ion exchange (**IX**) with bicarbonate elution is used at LHUM for treatment of the resultant pregnant leach solution (**PLS**). Although technically compatible with the Tumas PLS, IX was not considered for use at Tumas due to the inherent limitations it places on the hydrometallurgical circuit carbonate balance.

In place of IX, PLS concentration using nanofiltration (**NF**) membranes was selected for its ability to achieve a clean separation of uranium and carbonate (as well as vanadium and sulphate) from water, producing a permeate low in carbonate and uranium for use as CCD wash, with the PLS concentrate retained for further treatment to remove uranium, vanadium and sulphate, with the residual carbonate being recycled to leach.

In this way, the Tumas process could produce a final tailing slurry containing low levels of all value components, namely uranium, vanadium and carbonate, with consequent economic and environmental benefits over and above LHUM. This also has the benefit that the tailings stream has low levels of radioactive components and hence is considered benign. This view is supported by independent modelling conducted by CSIRO for the Project.

The PLS concentrate treatment process was developed specifically to remove all components that were concentrated across the NF membranes except carbonate; namely uranium (present as sodium uranyl carbonate), vanadium (present as sodium vanadate) and sulphate (present as sodium sulphate).

For personal use only

## Annexure A (continued)

Tumas Project  
Definitive Feasibility Study Report – Addendum 1  
Chapter 1 – Executive Summary



In summary, the selected PLS concentrate treatment process comprises:

- vanadium precipitation using lead carbonate;
- sodium diuranate (**SDU**) precipitation internally regenerating caustic;
- causticisation of uranium barren liquor using slaked lime;
- crystallisation of sodium sulphate from caustic product liquor; and
- carbonation of uranium barren liquor using boiler flue gas.

Carbonated liquor is returned to the Beneficiation area, where make-up sodium carbonate solids are added to maintain the required concentration in the leach liquor.

A simplified block flow diagram of the Tumas process that forms the basis of this study is shown in Figure 13.

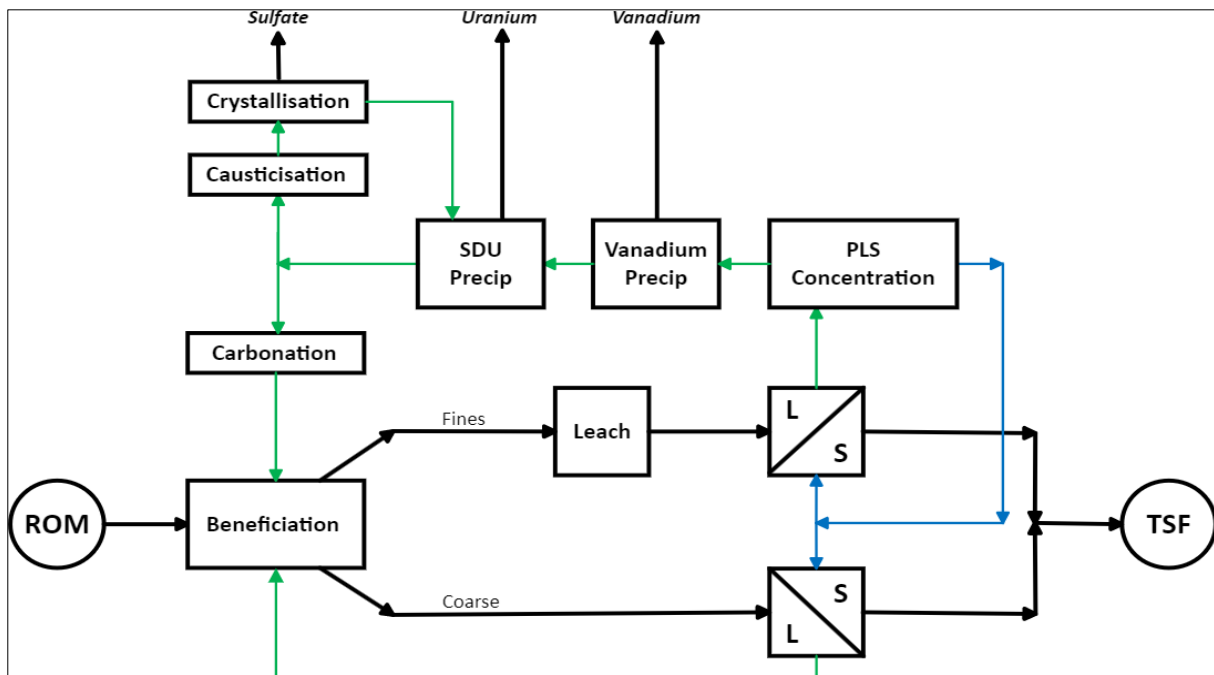

Figure 13: Block Flow Diagram.

### 1.10.2 Metallurgical Testwork Programs

Two distinct metallurgical testwork programs were conducted to support the Tumas Feasibility Study (**FS**). The first utilised a single 270 kg ore composite which was used to develop those parts of the process where chemical and/or physical performance is directly linked to the ore properties, namely:

- beneficiation;
- leach; and
- CCD.

# Annexure A (continued)

A second testwork program covered the unit operations downstream of pregnant leach solution (PLS) concentration, namely:

- vanadium precipitation;
- uranium precipitation;
- causticisation;
- crystallisation; and
- carbonation.

This work used synthetic liquors whose composition was based on the mass balance, calibrated to match the results of the beneficiation/leach/CCD testwork and trade-off study work.

A final testwork program was then conducted on a bulk sample developed from large diameter diamond core holes to allow the entire process to be tested on process liquors derived from Tumas material and develop product samples for analysis and comparison to established product penalty and rejection limits.

### 1.10.3 Sample Selection and Composite

The FS is supported by a testwork program undertaken at the ALS Metallurgy laboratory in Perth, which commenced in July 2021. The first phase of the testwork scope is sensitive to the physical characteristics of the ore (beneficiation, solid/liquid separation and leach), and as such, was performed using material from a single bulk composite comprised exclusively of diamond core samples. Collectively, the samples provide a reasonable reflection of the Tumas 3 Indicated Mineral Resource. Variability testwork will be performed on a range of composites at a later phase in the testwork program.

The completed FS composite sample weighed 340 kg with a head grade of 374 g/t U<sub>3</sub>O<sub>8</sub>. A summary of the composition of the FS composite can be found in Table 6.

For the final testwork program, 19 PQ diamond holes were drilled across the Tumas 3 ore body, selected to represent known variation within the Tumas 3 resource. A composite (P3 Bulk Comp) comprising 380 kg, with an average grade of 370 ppm U<sub>3</sub>O<sub>8</sub> was developed from these samples to complete the work (refer Table 6). This composite compares well with the Process Design Criteria (PDC) levels also shown in Table 6. Remaining material was used to undertake variability testing at the end of this work program.

**Table 6: FS Composite Head Assay vs PDC.**

Sample	U <sub>3</sub> O <sub>8</sub> (g/t)	V <sub>2</sub> O <sub>5</sub> (g/t)	S (g/t)	Cl (Water soluble) (mg Cl /kg Solids)	Moisture (% w/w)	Top Size <sup>1</sup> P <sub>100</sub> (mm)
DFS Comp	374	189	< 200	1200	4.01	10
P3 Bulk Comp	370	193	250	1250	5.76	65
PDC	350	113	350	12002	4.01	200

## Annexure A (continued)

Tumas Project  
Definitive Feasibility Study Report – Addendum 1  
Chapter 1 – Executive Summary



### 1.10.4 Beneficiation

A comprehensive beneficiation metallurgical testwork program was undertaken using the FS feed composite sample and bulk sample. At the highest level, the metallurgical objective of the beneficiation circuit is to achieve a clean physical separation of clasts (coarse silicate particles containing no uranium) and cement (fine calcrete containing the sole value mineral, carnotite) present in the ore.

This objective will be achieved via primary autogenous milling followed by separation of the high-grade fines (minus 1,000 micron) and low-grade coarse (+1,000 micron) material.

The low-grade coarse material will be processed in an autogenous mill in closed circuit with screens, secondary and tertiary crushers. Coarse tailing will be rejected from this circuit at +65 micron and minus 4,000 micron.

The high-grade fine material will be milled in a low-speed ball mill using ceramic media. This mill will be in open circuit and reject a coarse tailing of +65 micron.

The results of the beneficiation testwork were used to calibrate a model that was then used to determine the mill operating points that would deliver optimum process economics. The resultant Beneficiation mass and uranium deportment are as follows:

Recovery to leach feed:

- Mass 50%
- Uranium 96.3%

### 1.10.5 Leach

A leach testwork program was completed as part of the wider FS metallurgical testwork scope with the objective of determining optimum leach conditions (temperature, reagent concentration and time) for use in the Mar '25 DFS. Tested conditions encompassed the following ranges:

- slurry solids content 30% w/w
- temperature 90 to 170°C
- liquor sodium carbonate concentration 15 to 30 g/L.

As a result, the following leach conditions were selected for use in this study:

- temperature 90°C
- liquor sodium carbonate concentration 20 g/L.

The leach test results were used to calibrate a kinetic model which was then used to determine the optimum residence time. This was found to be 36 h (6 x CSTR's @ 6 h each) which will extract 97.1% of the uranium in the leach feed solids.

For personal use only

## Annexure A (continued)

Tumas Project  
Definitive Feasibility Study Report – Addendum 1  
Chapter 1 – Executive Summary



In general, the leach liquors produced were found to contain vanadium at a V:U molar ratio of 0.9 to 1.1 n/n, supporting the view that the only soluble vanadium mineral at the prevailing leach conditions is carnotite, and that vanadium is present in carnotite at a uranium molar ratio of 1.0 (i.e.,  $K_2(UO_2)_2(VO_4)_2$ ).

### 1.10.6 Solid-Liquid Separation

A Solid Liquid Separation (**SLS**) testwork program was completed as part of the metallurgical testwork scope with the objective of defining settling performance and SLS equipment sizing and selection criteria. The program focussed on the settling performance in SLS applications on ore derived process streams, specifically leach feed thickening and CCD areas. The testwork was completed independently by two of the major SLS equipment vendors, FLSmidth & Co. A/S (**FLS**) and Metso Öutotec Corporation (**MO**).

This work was used to select and specify leach feed and CCD thickener sizing together with corresponding flocculant and/or coagulant dose rates.

In summary, the CCD circuit will comprise 7 x 40 m diameter high-rate thickeners in series, with a wash ratio of 1.1 and design underflow density of 30% solids to achieve an overall wash efficiency of over 99%.

### 1.10.7 PLS Concentration

The PLS concentration circuit comprises clarification, mixed media filtration and ultra-filtration (**UF**) for removal of (fine) suspended solids from the PLS. This is followed by a nano-filtration circuit which separates mono-valent ions (chloride) and the bulk of the water from the remaining multi-valent ions (carbonate, sulphate, uranium and vanadium), which are thereby concentrated.

NF testwork was undertaken using a continuous mini pilot rig to establish long term membrane performance with respect to both throughput (flux) and selectivity. On the basis of this work a suitable membrane configuration has been determined and bulk solution prepared for further testwork phases. The clarifier is a 55 m diameter conventional clarifier and the mixed media filters are sized based on vendor recommendations.

### 1.10.8 Vanadium Precipitation and Refining

The Tumas process uses lead to selectively precipitate vanadium from the NF concentrate due to its ability to strongly and selectively precipitate vanadium as lead vanadate. As applied to the Tumas process, vanadium precipitation comprises three sequential steps:

1. Vanadium precipitation: mixing NF concentrate with lead carbonate; precipitating lead vanadate and producing Vanadium Baren Liquor (**VBL**).
2. Vanadium leach: mixing sulfuric acid with lead vanadate/carbonate; generating vanadyl sulphate liquor and precipitating lead sulphate.
3. Lead conversion: mixing sodium carbonate solution with lead sulphate; generating sodium sulphate liquor (waste) and precipitating lead carbonate for re-use.

For personal use only

## Annexure A (continued)

Tumas Project  
Definitive Feasibility Study Report – Addendum 1  
Chapter 1 – Executive Summary



A series of batch tests (38 tests @ 1 to 5 L each) using synthetic NF concentrate were completed covering all three sub-operations to establish base conditions and subsequently process design data was developed using solutions derived solely from Tumas ore composites

The vanadyl sulphate liquor produced from the above process is both concentrated (40 g/L  $V_2O_5$ ) and low in volume (1.4 m<sup>3</sup>/h) leading to a low variable cost of vanadium production for this process. This liquor will be processed in a dedicated ion exchange circuit to remove remaining traces of uranium that have been physically transferred during vanadium precipitation. The uranium-free liquor will be further processed to red cake flake ( $V_2O_5$ ) using conventional processes.

### 1.10.9 Uranium Precipitation and Refining

Uranium is precipitated as SDU from the VBL using an internally generated dilute sodium hydroxide (caustic) solution (see section 1.10.10 Causticisation) and creating Uranium Barren Liquor (**UBL**).

A series of batch SDU precipitation tests (11 tests @ 1 to 5 L each) were completed. The precipitation tests used vanadium barren liquor generated from the preceding vanadium precipitation tests. Again, the synthetic derived liquors were used to establish indicated design conditions and then verified using Tumas bulk sample derived solutions. This testwork program has established suitable design criteria for the Project that are within the expected parameters.

SDU produced from Tumas bulk sample was also converted to uranyl peroxide using conventional methodologies and suitable design criteria established. The uranyl peroxide was then roasted to  $U_3O_8$  and the final product, taken from Tumas composite through to  $U_3O_8$ , sent to a suitable laboratory for complete analysis and comparison to established penalty and rejection thresholds. The Tumas-derived  $U_3O_8$  did not exceed any of the established penalty or rejection levels, being well within the penalty limit in all cases.

### 1.10.10 Causticisation

Causticisation is a mature commercial process for converting sodium carbonate, present in the advancing UBL, into sodium hydroxide, which is required for SDU precipitation. The process uses a slaked quick lime reagent to drive the reaction, producing an insoluble calcium carbonate residue. The product slurry is filtered and washed, with the caustic liquor advancing to sulphate crystallisation and solids returned to the leach circuit.

During the testwork program, several causticisation batch tests were performed at both 2 L and 100 L scale. Product slurry from the 100 L tests was used for solid- liquid separation testwork to size and specify the associated equipment.

### 1.10.11 Crystallisation

Sodium sulphate crystallisation is used in the Tumas flowsheet as a method of selectively removing sulphate from the process. Sodium sulphate enters the process primarily via the dissolution of gypsum in the ore, and concentrates in the process, following the carbonate, uranyl carbonate and vanadate ions through the nanofiltration stages into the NF concentrate.

For personal use only

# Annexure A (continued)

Tumas Project  
Definitive Feasibility Study Report – Addendum 1  
Chapter 1 – Executive Summary



The capacity of the nanofiltration circuit to concentrate the PLS is limited by the total concentration of carbonate and sulphate in the PLS. As a result, limiting the recycle of sodium sulphate in the carbonated UBL enables a higher concentration upgrade of carbonate/uranium over the membrane circuit, reducing both the size (impact on capital cost) and operating cost of downstream precipitation circuits.

Flash cooling crystallisation of sodium sulphate in the decahydrate form (Glauber's salt) is a commonly used method of sodium sulphate removal in industrial refining process such as lithium hydroxide production. The process relies on the differential solubility at lower temperatures of sodium sulphate against other aqueous salts to selectively crystallise Glauber's salt from the stream. A third-party equipment vendor was selected to undertake the design criteria and design development of a suitable crystallisation unit for the Tumas Process. This work, including associated testwork has been completed and the design of this unit operation finalised.

## 1.10.12 Carbonation

Carbonation is a process which reacts carbon dioxide ( $\text{CO}_2$ ) with aqueous sodium hydroxide ( $\text{NaOH}$ ) to form sodium carbonate ( $\text{Na}_2\text{CO}_3$ ) and then, with further  $\text{CO}_2$  addition, sodium bicarbonate ( $\text{NaHCO}_3$ ). In the context of the Tumas flowsheet,  $\text{CO}_2$ , available in the Heavy Fuel Oil (**HFO**) steam boiler flue gas, is contacted in a packed bed column with the UBL converting the contained  $\text{NaOH}$  into  $\text{Na}_2\text{CO}_3$  and a moderate amount of sodium bicarbonate prior to entering the leach circuit. The conversion of residual caustic in the UBL into  $\text{Na}_2\text{CO}_3$  and moderate amounts of  $\text{NaHCO}_3$  is necessary to prevent caustic from inhibiting the leach chemistry.

The carbonation process has been successfully implemented in at-least two comparable uranium applications, Beaverlodge (decommissioned) and Tummalapalle. The two applications differ slightly in equipment selection making use of flotation cells and batch CSTR respectively as the liquid-gas contacting equipment.

A bench scale carbonation testwork program as well as a mini-pilot program was undertaken at ALS metallurgy in Perth with the objective of providing a data set of  $\text{CO}_2$  utilisation as a function of solution residence time to inform equipment selection and sizing. The testwork initially made use of a synthetic UBL feed stock (initially), followed by ore-derived UBL, compressed  $\text{CO}_2$  reagent and compressed air. With the prevailing flue gas volumes expected, even at minimum steam production rates, a minimum  $\text{CO}_2$  utilisation of 32% is required within the carbonation area. Given testwork has shown that 70% is conservative, ample  $\text{CO}_2$  will be available to drive the required carbonation chemistry.

## 1.11 Processing

The Tumas processing plant is designed to treat up to 4.2 Mt/y of carbonate ore containing carnotite ( $\text{K}_2(\text{UO}_2)_2(\text{VO}_4)_2 \cdot 3\text{H}_2\text{O}$ ) as the uranium bearing mineral from an open pit mine to produce up to 3.6 Mlb/y uranium yellow cake ( $\text{U}_3\text{O}_8$ ) product and 1.1 Mlb/y vanadium ( $\text{V}_2\text{O}_5$ ) by-product over a 30-year mine life. The key drivers in the development of the process route are:

- high process recoveries;
- low operating cost;

For personal use only

## Annexure A (continued)

- operability;
- known unit processes; and
- walk-away rehabilitation strategy.

Of these, the last – a walk-away rehabilitation strategy – is perhaps the most significant. The process was developed with the aim of developing a benign tailing, where a “benign tailing” is characterised by its stability, particular with respect to ground water impact. Deep Yellow has achieved independent, third-party endorsement of the process in this regard from the CSIRO. The process selected consists of:

- beneficiation to reject 50% of ROM mass to a coarse tailing;
- atmospheric leach at 90°C to extract uranium and vanadium;
- counter current decantation (**CCD**) to wash leached metals and reagents to pregnant leach solution (**PLS**);
- ultrafiltration (**UF**) and nanofiltration (**NF**) to concentrate the PLS;
- a refinery section to first remove vanadium from the circuit as a value by- product and then uranium;
- vanadium packaging;
- uranium roast to  $U_3O_8$  and packaging;
- reagent recycle; and
- tailings disposal with tailings decant water recovery and recycle.

### 1.11.1 Process Design

The process concept for Tumas has remained unchanged since the PFS, but there have been changes in the equipment selection and detailed flowsheet, such that the current process consists of the following:

- Run of Mine (**ROM**) autogenous primary mill, with an open circuit fine mill and course mill in closed circuit with crushing and screening, to produce a leach feed stream comprising 50% of the ore mass and 96.3% of the uranium and coarse tailing stream containing the balance of the ROM ore;
- 6 agitated tank leach reactors, providing 36 hours leach residence time and leach conditions of 90°C and 20 g/L  $Na_2CO_3$ . Leach extraction of 97.1%;
- 7 stages of CCD to produce a washed fine tailing stream and PLS;
- PLS pre-treatment consisting of clarification, mixed media filtration and UF;
- NF membrane treatment on the pre-treated PLS to produce an NF concentrate and permeate, where the NF concentrate (**NFC**) contains 99.8% of the uranium, vanadium and sodium carbonate and the permeate comprises over 90% of the PLS volume and is used as CCD wash;

## Annexure A (continued)

- removal and recovery of vanadium as a value product from the NFC to produce VBL;
- conventional recovery of uranium as SDU from the VBL to produce UBL and then further conventional treatment of the SDU to produce  $U_3O_8$  as a final product;
- further treatment of the UBL through:
  - causticisation to produce caustic reagent for recycle;
  - crystallisation of the causticisation product to remove sodium sulphate for disposal;
  - carbonation to produce sodium carbonate solution for recycle as leach lixiviant; and
  - combined disposal of the coarse and fine tailing in a conventional in-pit TSF where the tailings and any associated seepage are considered benign in environmental terms.

The Tumas process design basis is that:

- leach, PLS concentration and CCD have a design capacity and will operate at that capacity; and
- beneficiation, tailings and the refining sections are sized to accommodate reasonable variations in ore characteristics to maintain steady state in leach, PLS concentration and CCD.

### 1.11.2 Process Description

The processing plant includes the following unit processes:

- beneficiation;
- leaching;
- solid liquid separation;
- PLS concentration;
- vanadium recovery;
- uranium recovery;
- uranium barren liquor (**UBL**) treatment;
- tailings disposal;
- reagent make-up and distribution; and
- water and air services.

The process plant schematic process flow diagram is presented in Figure 14 and the key design criteria are summarised in Table 7.

# Annexure A (continued)

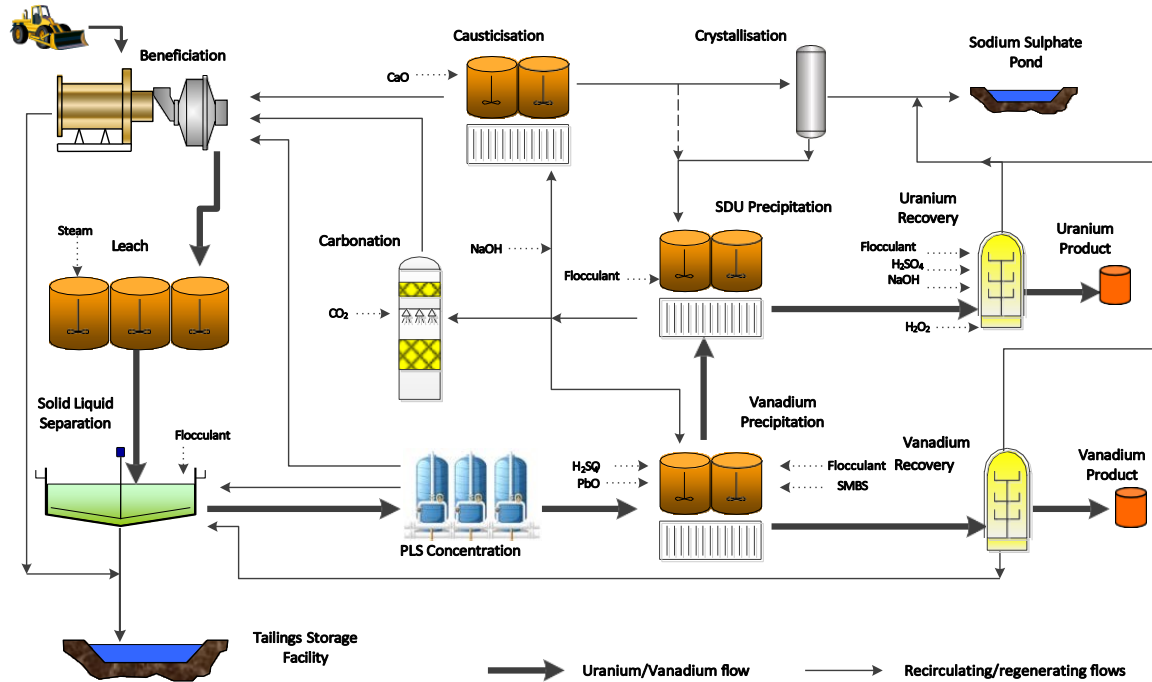

Figure 14: Schematic Process Flow Diagram.

Table 7: Key Design Criteria.

Production Measure	Unit	Nominal Value
Run of Mine (ROM) ore processed	dry Mt/y	4.2
Uranium in ore (as U <sub>3</sub> O <sub>8</sub> )	g/t dry basis	350
Overall U <sub>3</sub> O <sub>8</sub> recovery	%	92.7
Uranium in product (as U <sub>3</sub> O <sub>8</sub> )	Mlb/y	3.0*
Vanadium in ore (as V <sub>2</sub> O <sub>5</sub> )	g/t dry basis	113
Overall plant availability	%	90
Beneficiation recovery to leach feed	% w/w ROM ore	50
Beneficiation recovery to leach feed	% U <sub>3</sub> O <sub>8</sub>	96.3
Leach residence time	h	36
Leach temperature	°C	90
Leach reagent	g/L Na <sub>2</sub> CO <sub>3</sub>	20
Solid liquid separation	type	CCD thickeners
Solid liquid separation	stages	7
Vanadium product purity	% w/w dry V <sub>2</sub> O <sub>5</sub>	>90
Uranium product purity	% w/w dry U <sub>3</sub> O <sub>8</sub>	>90

\* It is noted that while the front end of the plant is limited to 4.2 Mt/y, the back end of the plant has a maximum capacity of 3.6 Mlb/y, thereby accommodating a 20% increase in ROM feed grade when available.

### 1.11.3 Plant Layout

The overall process plant layout illustrated in Figure 15 is driven primarily by:

- minimising pumping distances between areas, especially for high volume or slurry applications;

For personal use only

## Annexure A (continued)

Tumas Project  
Definitive Feasibility Study Report – Addendum 1  
Chapter 1 – Executive Summary



- optimising the use of gravity flow;
- the requirement for a “clean side / dirty side” configuration;
- separation of delivery vehicle traffic from the process plant; and
- separation of final product movement from the process plant and other vehicle traffic.

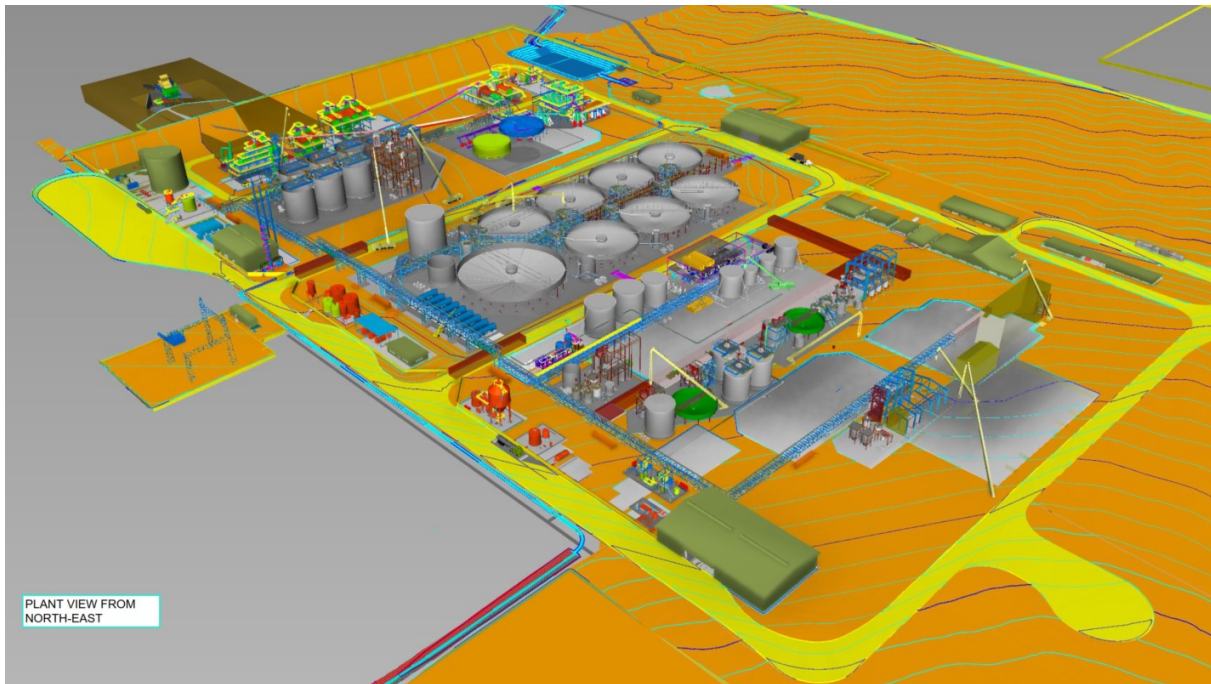

*Figure 15: Plant Layout.*

### 1.12 Tailings and Water Management

#### 1.12.1 Tailings Characterisation

Deep Yellow’s strategy for the process plant design was to produce a tailings stream that would not have a long-term impact on the environment and would enable Deep Yellow to “walk away” from the project once the final rehabilitation processes had been completed.

Tailings characterisation testwork indicates that the tailings generated by the process plant are benign and will not release any contaminants into the environment. As a result, the TSFs are not required to be lined and will not require any ongoing management after mine closure.

#### 1.12.2 Tailings Disposal

Being a shallow lenticular orebody, the Tumas deposit lends itself to the implementation of an in-pit tailings disposal methodology, whereby mined-out pits are back-filled with tailings, covered and rehabilitated back to the original landform. This methodology can only be applied to tailings that are benign and do not require storage in lined facilities.

All Tumas tailings will be stored permanently in mined-out areas of the Tumas 3 resource area, which are all within eight kilometres of the process plant.

For personal use only

## Annexure A (continued)

Tumas Project  
Definitive Feasibility Study Report – Addendum 1  
Chapter 1 – Executive Summary



The Tumas resource contains a number of smaller pits that will be mined out and then serve as individual tailings cells. Larger pits will be divided into sections with embankments constructed from mine waste, aligned where the pit floor is at higher elevations, to reduce the required earthworks. Figure 16 illustrates how divider embankments are constructed within the pit and then used to manage the progression of tailings deposition.

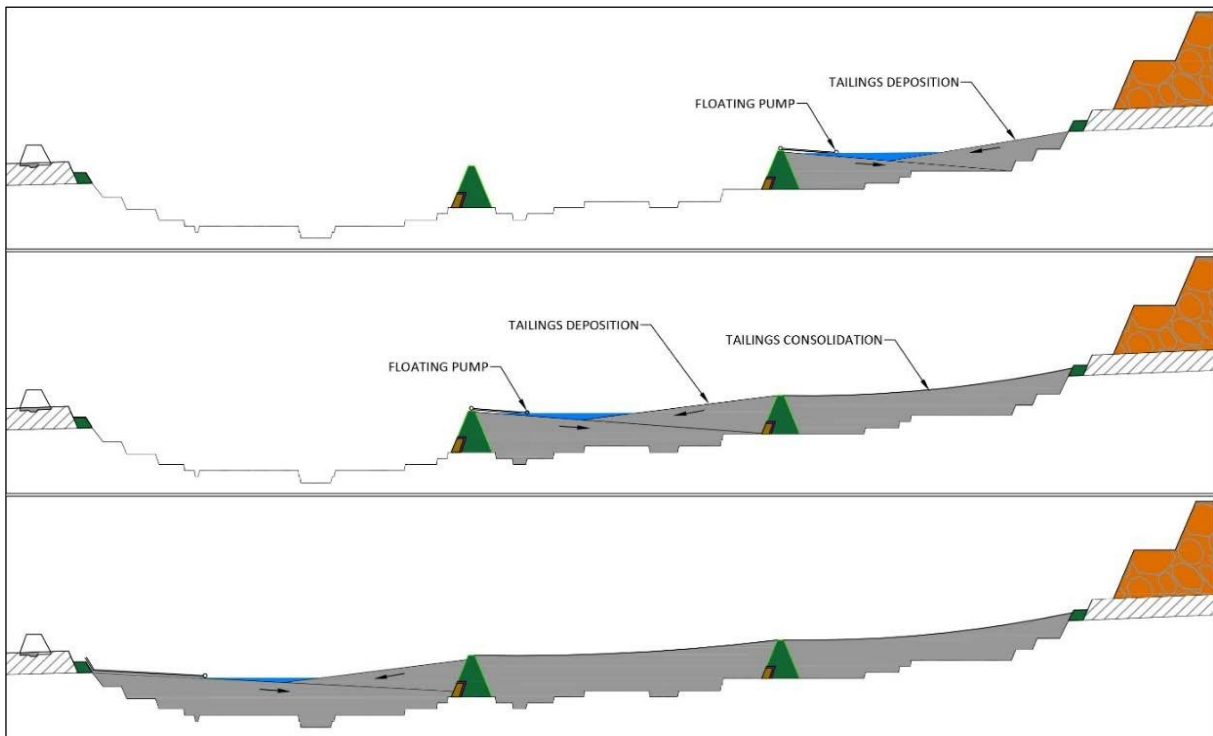

**Figure 16: Tailings Deposition Sequencing.**

Water released from the tailings as they consolidate reports to the supernatant pond and is reclaimed for return to the process plant for re-use.

### 1.12.3 Sodium Sulphate Pond

Sulphate effluent, comprising sodium sulphate as Glauber's salt and vanadium conversion effluent, is pumped from the process plant to a nearby spent mine pit (Tumas 3\_B) where the water contained in the effluent is allowed to evaporate. The pit has sufficient capacity to hold the LOM production of sodium sulphate (380,000 m<sup>3</sup>) and will be capped with two metres of waste rock once decommissioned.

### 1.12.4 Hydrogeology

The palaeochannel hosting the Tumas deposits comprises sandy conglomerate, calcareous grit, calcareous silt/clay and calcareous conglomerate, and follows a similar flow path to the Tumas and Tubas Rivers. The palaeochannel sediments increase in permeability downstream and host the only aquifer of local significance.

## Annexure A (continued)

Tumas Project  
Definitive Feasibility Study Report – Addendum 1  
Chapter 1 – Executive Summary



Six production boreholes have been drilled into the western extent of the palaeochannel within the project area and will be suitable for the provision of dust suppression water whilst serving to assist in dewatering active mining areas. The groundwater intersected is saline and unsuitable for use in the process plant without treatment.

A groundwater model has been developed to simulate the impact of mining on the palaeochannel aquifer. Figure 17 shows that whilst the production bores in the western portion of the project area have a noticeable impact whilst they are operating, the drawdowns around the various mining areas is transient and will recover quickly.

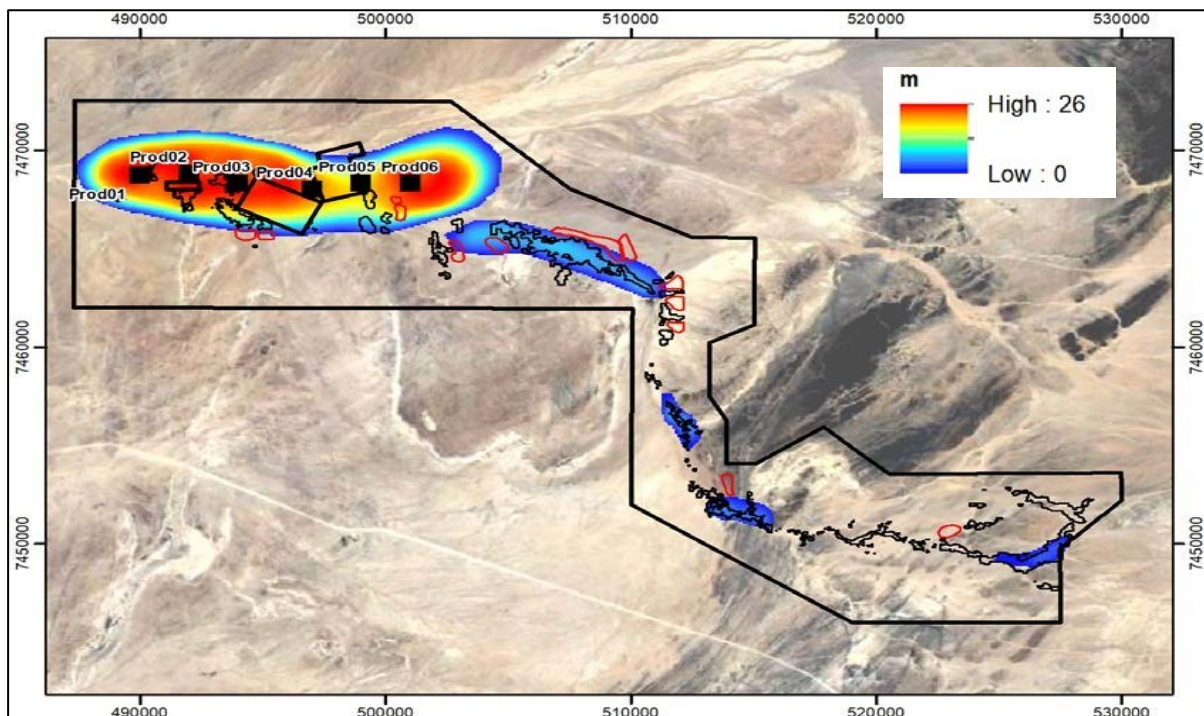

**Figure 17: Groundwater Level Drawdown Levels in Year 30.**

### 1.12.5 Hydrology

The project area is drained mainly by minor drainage lines and washes flowing in an east-west direction to join the Tumas River. The Tumas drainage starts initially as a braided system east of the ridges and then passes through a major bedrock drainage constriction in the centre of the project area, where it becomes narrow and incised. The rivers and other smaller washes and drainage lines in and near to the project area do not have regular surface flow as most surface water flow either seeps into the ground and recharges the groundwater or evaporates.

### 1.12.6 Surface Water Management

As the project lies in an arid region with no surface water expression, surface water management focusses around the management of surface flows during and after significant storm events. As each pit is developed, stormwater control bunds and waste rock dumps are constructed to divert runoff around the open pits and back to the original water course to the west of the project area. The bunds are developed progressively in parallel with the mining and backfill schedules.

# Annexure A (continued)

## 1.12.7 Water Balance

The site water balance indicates that, excluding bore water, which is all lost to evaporation eventually, 60% of the water losses are retained in tailings and 39% is lost to evaporation. Raw water supplied by pipeline accounts for 82.5% of the make-up water requirements with moisture in the ore, reagent supply water and bore water the remaining 17.5%.

## 1.13 Infrastructure and Services

Both offsite and onsite infrastructure is required for the Tumas Project. Offsite infrastructure encompasses site access, via a dedicated road, and delivery of water and power utilities. Figure 18 illustrates the locations (and routing) of the main offsite infrastructure, whilst Figure 19 shows the onsite infrastructure, which includes the construction camp, processing plant, Mining Infrastructure Area (MIA) and non-process buildings.

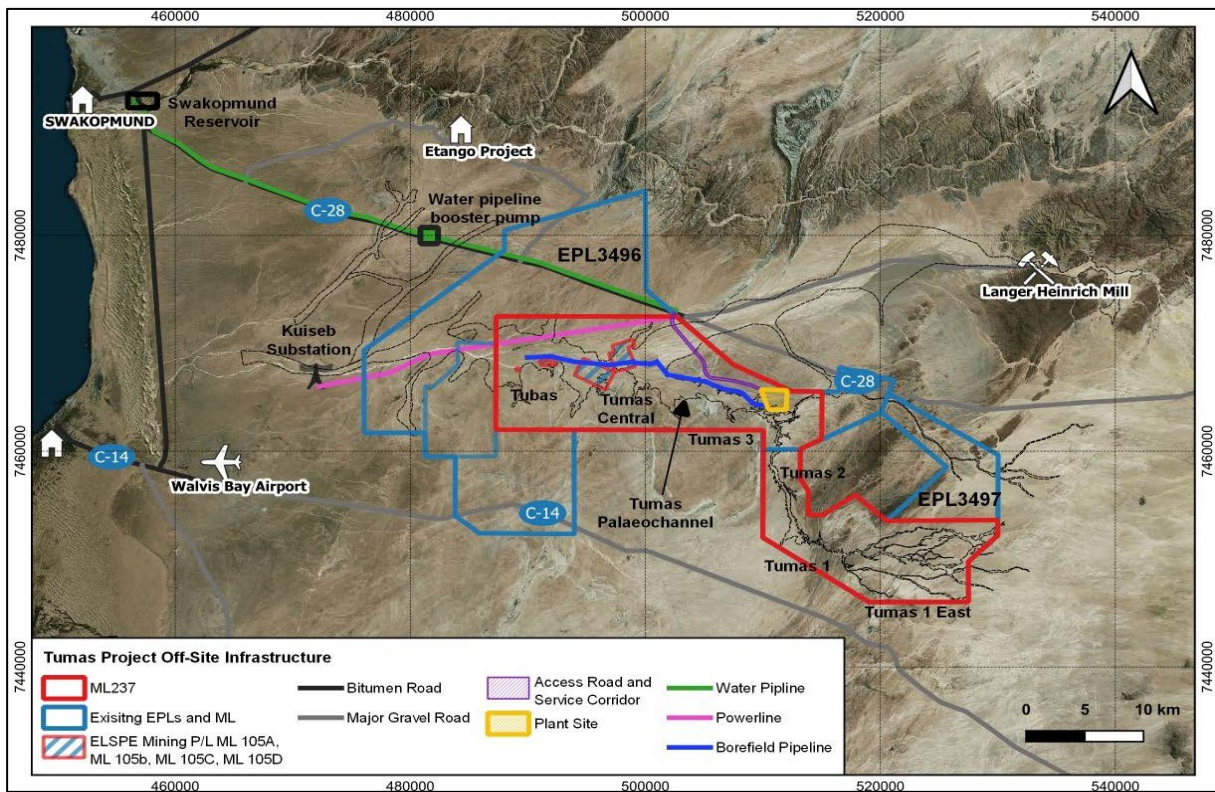

Figure 18: Offsite Infrastructure Layout.



# Annexure A (continued)

Tumas Project  
Definitive Feasibility Study Report – Addendum 1  
Chapter 1 – Executive Summary



## 1.13.2 Power Supply

The Tumas Project is to be connected to the Namibian regional grid through a purpose-built dedicated 22 km 220 kV power line. This line will be constructed by the Project and handed over to the Namibian Power Corporation (Proprietary) Ltd (**NamPower**) after commissioning. The power line is supplemented by a 25 MW onsite solar farm installed and operated by a third party under an independent power producer (**IPP**) arrangement. The solar farm requires approximately 45 ha and is located immediately to the east of the process plant.

The incoming power is stepped down to 11 kV at the main Tumas substation and is distributed to the main switchboards in the process plant.

Emergency back-up power is provided through a number of small diesel generators located at electrical sub-stations and the solar array.

## 1.13.3 Water Supply

Fresh water is supplied from the Namibia Water Corporation (**NamWater**) - managed Swakopmund Reservoir via a 2.5 GL/y 65 km pipeline running parallel to the C28 highway.

The aquifer within the paleochannel hosting the uranium mineralisation contains saline water. All water extracted from dewatering bores is used for dust suppression only.

## 1.13.4 Site Infrastructure

The smaller onsite support buildings (administration, security, mess, clinics, etc.) are constructed from brick and mortar, while the larger buildings (workshop, reagents store) are of structural steel construction. All buildings are custom designed for the Project as there are no pre-existing buildings.

Infrastructure required for the mining fleet will be established by the mining contractor.

## 1.13.5 Site Accommodation

As no permanent accommodation is permitted within the NNNP, all permanent employees reside in either Walvis Bay, Swakopmund or nearby and will be bussed to site daily. Mining licence conditions permit the establishment of an accommodation camp onsite for construction purposes only. Once construction is completed, the camp will be decommissioned and removed from site except for several of the entertainment buildings that will be repurposed as training and induction facilities.

## 1.14 Project Execution

The Project Execution Plan is based on an Engineering, Procurement and Construction Management (**EPCM**) execution model, with Ausenco providing EPCM services for the process plant on-site infrastructure.

For personal use only

## Annexure A (continued)

Tumas Project  
Definitive Feasibility Study Report – Addendum 1  
Chapter 1 – Executive Summary



This execution model has been adopted to meet the following key project drivers:

- delivery of a safe and environmentally compliant processing plant facility that is constructable and operable as a Capital efficient asset, designed to achieve operating cost forecasts and meeting all environmental and regulatory requirements;
- maintain project execution flexibility and minimise post DFS expenditure whilst Deep Yellow obtains optimal funding approval; and
- wet commissioning completion (C3) and commencement of production ramp-up in 24-months after FID.

The project schedule has been developed based on continuous development of the integrated Deep Yellow and Ausenco team approach used during the DFS, with each party contributing in the areas of their respective strengths and scopes of work. Deep Yellow will provide the overall leadership to make key project decisions; manage community, environmental, permitting, local authorities, resource, mining, geometallurgy, metallurgy, off-site infrastructure and security whilst Ausenco will provide engineering, procurement, management and execution personnel for the process plant and on-site infrastructure, that are experienced in cost effective project delivery in accordance with both Namibian and International design standards.

The implementation strategy assumes an EPCM implementation with horizontal construction packages and some smaller EPC packages where either local contractor or specialist technology suppliers have demonstrated cost benefits to the project.

The execution phase has been split into two sub-phases to suit funding requirements, maintain ramp-up of production milestone within 24-months of FID and take advantage of any significant shift in the price of uranium should this occur. The first phase will involve the continued construction of the offsite infrastructure and the commencement of detailed design of the process plant. The second phase (which will be subject to FID) will be for the fabrication and construction of the process plant and on-site infrastructure. This phased approach is configured to minimise capital spend prior to full project funding whilst addressing the projects early critical path activities and to determine the optimal project owner/contractor risk/reward profile prior to full project approval.

This approach provides Deep Yellow with the required time during the first phase to advance detailed engineering and critical procurement packages such that an optimised procurement, fabrication and contracting plan can be finalised. During this period the key long lead procurement items and on-site infrastructure packages can be tendered, evaluated and negotiated ready for immediate award and commencement at project full notice to proceed. Vendor data for critical equipment effecting the layout will be procured prior to FID.

Furthermore, this initial phase will focus on project setup of systems and tools to be used for the broader execution phase as well as the detail design phase. This will include baseline parameters and conventions, migration of key documentation and datasets from the DFS phase.

For personal use only

## Annexure A (continued)

Tumas Project  
Definitive Feasibility Study Report – Addendum 1  
Chapter 1 – Executive Summary



The EPCM Interim program is essential if production ramp-up is to commence within 24-months of FID as it enables the timely award and construction of:

- the high voltage powerline;
- the water pipeline from Swakopmund to site;
- the site access road from C28 to site; and
- the construction camp.

The critical path for the project consists of:

- vendor certified data driving critical engineering to provide Issued for Construction (IFC) documentation;
- EPCM commencement – Detailed Engineering Design to support SMP and E&I final pricing and construction;
- NamWater pipeline EPC contract commencement;
- NamPower powerline EPC contract commencement;
- wet and dry commissioning of the CCD area;
- construction of the CCD area; and
- ore commissioning.

Other activities which require further consideration in the next phase, as they influence multiple areas which are within 30 to 45 days of the critical path, are:

- concrete volumes require sequencing of three teams with a fourth smaller team to supplement construction;
- completion of the required engineering and procurement to finalise IFC status documentation to support the SMP contractor fabrication of structural steel, platework and piping spools; and
- electrical equipment lead times which could potentially impact completion of electrical switchrooms.

Schedule improvement and de-risking opportunities will be reviewed in the next phase by separating the supply and fabrication from the construction contracts.

Schedule improvement and de-risking opportunities will be reviewed in the period leading up to the FID through additional vendor and contractor engagement.

The bulk of the initial project execution effort will be undertaken in Perth with a gradual transfer of all activities to either the joint Deep Yellow and Ausenco Namibia office or the Site office (or a mixture of both). A summary of the key activities performed from the three project office locations follows:

For personal use only

## Annexure A (continued)

Tumas Project  
Definitive Feasibility Study Report – Addendum 1  
Chapter 1 – Executive Summary



- Deep Yellow and Ausenco’s Perth offices:
  - Deep Yellow’s Perth office will act as the offshore hub for the overall project governance, leadership, management of community, environmental, permitting, local authorities and security;
  - Ausenco’s Perth office will act as the offshore hub during the project set- up, engineering design and early international procurement phase. Overall project management will commence in the Perth office and will transition to Swakopmund and then site as the detail design and procurement phases draw to a conclusion. It will also provide ongoing support for the full execution phase; and
  - Deep Yellow and Ausenco personnel will be assigned to either office based on best-for-project outcome to coincide with the different project phases to promote a one team culture and optimise interfaces.
- Deep Yellow’s office in Swakopmund, Namibia:
  - Deep Yellow and Ausenco will establish a local team in a joint Namibian office to manage all local content up to the full transition to the site office.
- Deep Yellow’s site office at Tumas Site:
  - Deep Yellow and Ausenco will establish a site team utilising the joint office in Swakopmund. This team would then migrate to the site once construction begins. The team will expand as construction activities intensify up to the point the full project management and construction management team resides on site.

### 1.15 Capital Costs

The overall capital cost estimate has a base date of the fourth quarter 2024 (Q4 2024) with a revision date of 24 March 20 and this is a class 3 estimate as per the American Association of Cost Engineering International (**AACE**) - Guidelines for Documentation for Feasibility Study Engineering and Capital Cost Estimate. The estimate has a predicted accuracy range of -10% to +15% for the scope indicated. No escalation is included.

The Tumas Project estimate (refer Table 8) covers the development of the open pit mine, installation of a new process plant, a 22 km 220 kV powerline, a 66 km water pipeline, a 13.5 km site access road and support infrastructure such as roads, non-process infrastructure, construction camp, water and fuel services and a solar farm.

The estimates were prepared with reference to the AACE - Guidelines for Documentation for Feasibility Study Engineering and Capital Cost Estimate.

The capital cost estimate is based on a project delivered under an EPCM contracting strategy.

For personal use only

## Annexure A (continued)

Tumas Project  
Definitive Feasibility Study Report – Addendum 1  
Chapter 1 – Executive Summary



**Table 8: Total Project Execution Costs Summary.**

WBS <sup>1</sup>	Description	Cost (US\$M)
1000	Mining	13.5
2000	Process plant	283.8
4000	On site infrastructure	17.3
5000	Offsite infrastructure	25.2
6000	Construction indirects	30.4
7000	Project delivery	29.5
8000	Owner's costs	12.3
9000	Provisions	39.1
PP01	Pre-Production	22.7
<b>Grand Total</b>		<b>473.8</b>

<sup>1</sup> Work breakdown structure (WBS).

Based on the results of the Monte Carlo simulation, an Estimate Contingency of 9% of total direct and indirect costs, excluding mine pre-strip and owner's costs, has been included in the class 3 capital cost estimate.

A total of \$192M is allowed in the financial model for sustaining capital and closure, with an assumption that no sustaining capital will be required for the first or last 6 quarters of operation.

Capitalised pre-production operating costs are developed in the financial model and summarised in Table 9.

**Table 9: Capitalised Pre-Production Operating Costs.**

Cost Area	Cost (\$M)
Downstream pre-production capitalised operating costs	-
Mining pre-production capitalised operating costs	18.1
Processing and other pre-production capitalised operating costs	4.6
Royalties and export levies pre-production capitalised operating costs	-
<b>Total</b>	<b>22.7</b>

Maximum capital drawdown for the Project is estimated to be \$478M (real) and US\$491 (nominal).

A provision of \$25.0M has been included for closure costs in the financial model.

# Annexure A (continued)

Tumas Project  
Definitive Feasibility Study Report – Addendum 1  
Chapter 1 – Executive Summary



## 1.16 Operating Costs

### 1.16.1 Overall Operating Costs

The operating cost estimate uses prices obtained in, or escalated to, the first quarter of 2025 (Q1 2025).

In broad terms, the estimate includes all site-related operating costs associated with the mining and processing of ore to produce uranium yellow cake and vanadium biproduct.

Table 10 summarises the operating costs for the Tumas operation over the operating LOM (does not include capitalised pre-production mining by the mining contractor), including the cost per tonne of ore processed at the nominated throughput of 4.2 Mt/y. These costs have been developed in the financial model and there may be some variation with cost estimates discussed in this section that were developed in the operating cost model. The reason for this is that the financial model incorporated the variability experienced over the LOM whereas the operating cost model develops costs based on the PDC values, which are idealised in nature. Where costs are referenced as “LOM” in this section, they refer to the costs developed in the financial model.

Table 11 summarises the Operating cost for LOM.

**Table 10: LOM Real Operating Summary.**

Operating Costs (Real LOM)	LOM	\$/t ROM	\$/lb U <sub>3</sub> O <sub>8</sub>
Converter Costs	26.91	0.22	0.37
Transport & Shipping	47.48	0.40	0.65
Mining as incurred during production	1,190	9.91	16.25
Processing	1,408	11.72	19.23
Maintenance & Engineering	114.45	0.95	1.56
Site Management and Administration	149.84	1.25	2.05
SHR	30.87	0.26	0.42
Environment	10.05	0.08	0.14
HR	5.52	0.05	0.08
Community Relations	1.77	0.01	0.02
State Royalty	229.30	1.91	3.13
Export Levy	19.89	0.17	0.27
<b>Total Operating Costs as incurred during Production</b>	<b>3,234.15</b>	<b>26.93</b>	<b>44.16</b>
Pre-Production Mining Operating Cost transferred to Inventory	12.89	0.11	0.18
Mining Stockpile Adjustment	-	-	-
<b>Total Operating Costs as Reported under Cash Costs</b>	<b>3,247.04</b>	<b>27.03</b>	<b>44.34</b>

For personal use only

## Annexure A (continued)

Tumas Project  
Definitive Feasibility Study Report – Addendum 1  
Chapter 1 – Executive Summary



**Table 11: LOM C1 Operating Summary.**

Cost Centre	Cost Estimate LOM			
	\$pa (/1000)	\$/t	\$/lb U <sub>3</sub> O <sub>8</sub>	% of Total
<b>C1 Costs</b>				
Mining during Production	40,534	9.96	16.33	41%
Processing	38,140	9.37	15.36	38%
Maintenance and Engineering	11,483	2.82	4.63	12%
C&A	5,079	1.25	2.05	5%
SHR	899	0.22	0.36	1%
Environment	488	0.12	0.20	0%
HR	187	0.05	0.08	0%
Total Site Operating Cost	96,811	23.78	39.00	97%
Corporate and Marketing	2,578	0.63	1.04	3%
<b>Total</b>	<b>99,389</b>	<b>24.41</b>	<b>40.04</b>	<b>100%</b>
<b>Vanadium Offset</b>	<b>(3538)</b>	<b>(0.87)</b>	<b>(1.43)</b>	<b>(4%)</b>
<b>Total after Vanadium offset</b>	<b>95,851</b>	<b>23.54</b>	<b>38.61</b>	
Mining Stockpile Adjustment	-	-	-	
<b>C1 Cost for Reporting Purposes</b>	<b>95,851</b>	<b>23.54</b>	<b>38.61</b>	

### 1.16.2 Mining Costs

Mining costs are derived from tenders received from mining contractors based on an earlier version of the mine plan (though not significantly different to the final schedule).

Table 12 summarises the mining operating costs for the LOM. The majority of mining costs are considered variable costs as they are directly related to the volume of material to be moved and the distance it is to be moved. Fixed costs include the monthly contract management fee which covers the cost of the contractor supervisory and management team.

**Table 12: Average Annual Mining Operating Costs Over LOM.**

Cost Centre	LOM (\$M)	\$/t ROM	\$/lb U <sub>3</sub> O <sub>8</sub>
Contractor	32,527	8.14	13.10
Fuel	7,065	1.77	2.85
Owner's Team	755	0.19	0.30
Mobile Equipment (including Fuel)	187	0.05	0.08
<b>Total</b>	<b>40,534</b>	<b>10.14</b>	<b>16.33</b>

### 1.16.3 Processing

The design annual processing operating costs are summarised by primary area in Table 13 and illustrated in Figure 20. Of these costs, labour and maintenance are considered fixed costs and not impacted by variations in throughput or ore. In total, variable costs account for 63% of the total process plant operating costs.

For personal use only

## Annexure A (continued)

Tumas Project  
Definitive Feasibility Study Report – Addendum 1  
Chapter 1 – Executive Summary



The design annual processing operating costs are summarised by primary area in and illustrated in. Of these costs, labour and maintenance are considered fixed costs and not impacted by variations in throughput or ore. In total, variable costs account for 73.7% of the total process plant operating costs.

**Table 13: Design Annual Processing Operating Costs.**

Centre	Annual Cost (\$M)	\$/t ROM	\$/lb U <sub>3</sub> O <sub>8</sub>	% of Total
Company Labour	8.3	1.98	2.77	14
Purchased Water	4.2	0.99	1.38	7
Plant Fuels (HFO)	7.9	1.87	2.62	13
Plant Fuels (Diesel)	0.6	0.15	0.21	1
Other Reagents and Consumables	13.0	3.09	4.33	21
Power	11.5	2.72	3.81	19
Plant Maintenance	7.12	1.70	2.38	12
Maintenance Consumables	1.3	0.31	0.43	2
Mobile Equipment Leasing	1.8	0.44	0.61	3
Laboratory	0.5	0.12	0.16	1
General Expenses	4.5	1.07	1.49	7
<b>Total</b>	<b>60.8</b>	<b>14.44</b>	<b>20.20</b>	<b>100</b>

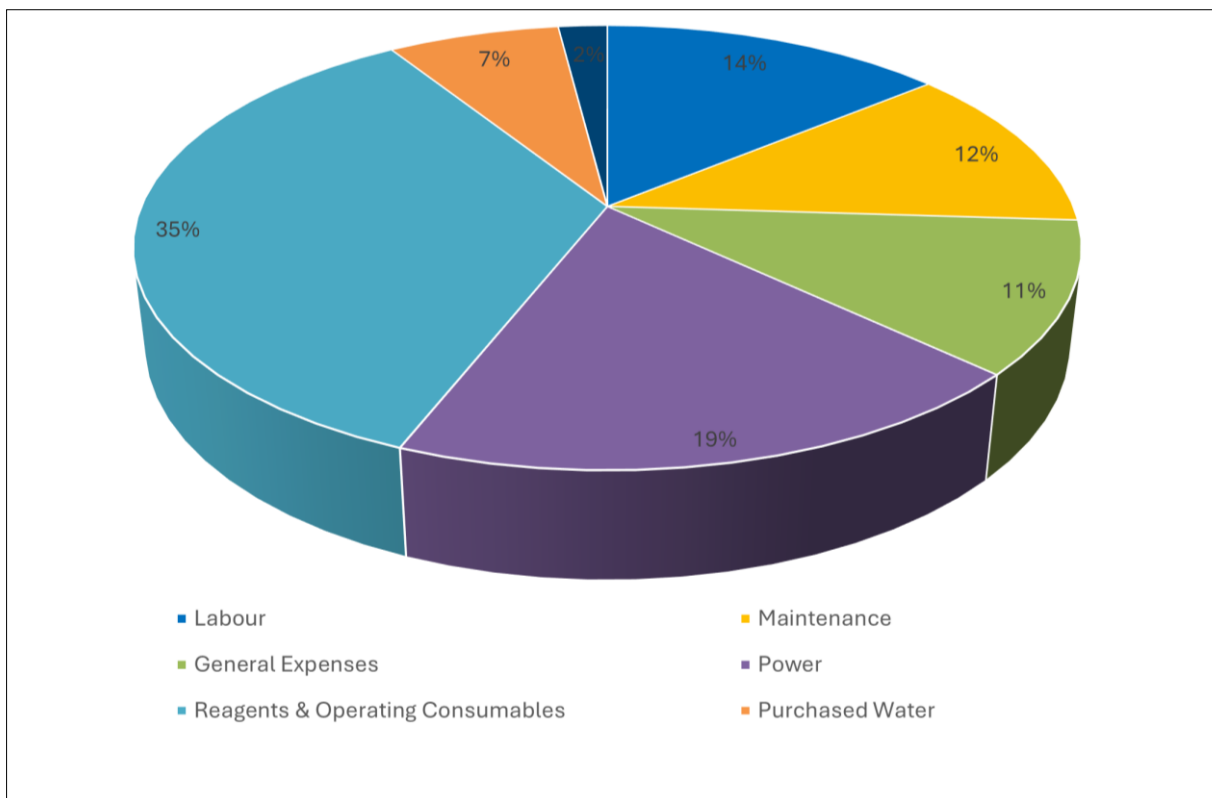

**Figure 20: Distribution of Processing and General Expenses Operating Costs.**

For personal use only

## Annexure A (continued)

Tumas Project  
Definitive Feasibility Study Report – Addendum 1  
Chapter 1 – Executive Summary



Table 14 presents the cost of the major reagents and consumables (by value) as a percentage of the total reagent and operating consumable costs. HFO (steam) accounts for 30% of the reagent and operating consumable costs. The next largest consumers are sodium carbonate ( $\text{Na}_2\text{CO}_3$ ) and water, accounting for 14 % and 16 % respectively. As a result, the processing plant operating costs are most sensitive to consumption and price of Heavy Fuel Oil (**HFO**) to produce steam, followed by sodium carbonate and purchased water.

**Table 14: Design Annual reagent and Consumable Costs.**

	Annual Cost (\$M)	\$/t ROM	\$/lb $\text{U}_3\text{O}_8$	% of Total
$\text{Na}_2\text{CO}_3$	3.7	0.89	1.24	14
Flocculant	1.7	0.40	0.55	6
Coagulant	0.7	0.16	0.22	3
Nanofiltration membranes	1.1	0.27	0.37	4
CaO	1.5	0.35	0.49	6
Purchased water	4.1	0.987	1.381	16
HFO	7.9	1.87	2.62	30
$\text{H}_2\text{O}_2$	0.4	0.10	0.14	2
Diesel	0.6	0.15	0.21	2
Other	3.9	0.93	1.30	17
<b>Totals</b>	<b>26.2</b>	<b>6.23</b>	<b>8.71</b>	<b>100</b>

### 1.17 Operating Strategy

The organisational structure for the Tumas Project is based on Deep Yellow managing the process plant and general administration functions while mining is undertaken by a contract miner and the solar farm is on a Build, Own, Operate and Transfer (**BOOT**) basis.

Table 15 documents the distribution of the site workforce headcount across the different departments. Shift rosters vary depending on the work area. Most work areas are predominantly day shift only, except for mining, ore processing, some engineering maintenance positions and stores access. A four-panel continuous shift roster is based on an eight-hour shift and applies to those positions that require 24/7 coverage. All work hours and rosters are based on compliance with Namibian labour laws. The mining contractor headcount fluctuates over time, in line with the mine schedule and ore/waste haulage distances.

The Project will source over 95% of the employees needed from the local population, with the majority from the Erongo region.

# Annexure A (continued)

The organisational structure for the organisation is a flat structure as depicted in Figure 21 below, with work teams reporting directly to the relevant managers.

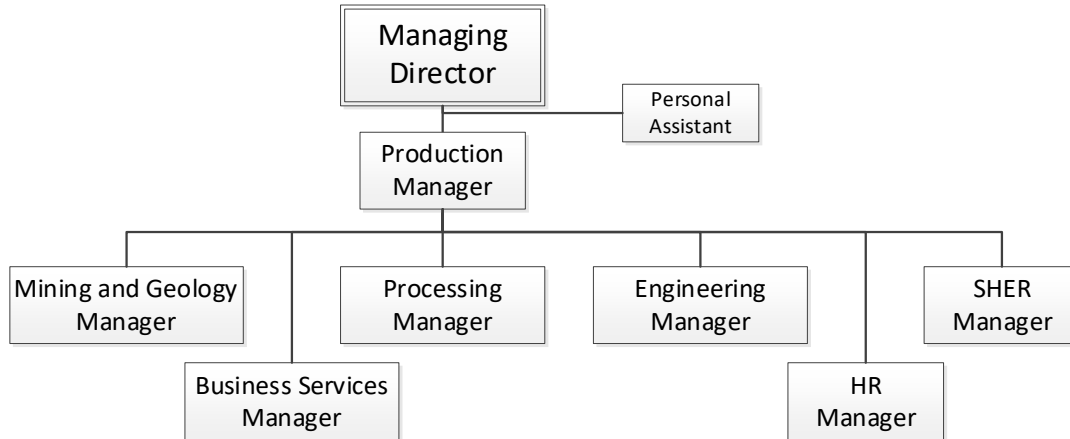

**Figure 21: Tumas Management Structure.**

**Table 15: Tumas Staffing Distribution.**

	Staff			Contractors	
	Expatriate	Local	Total	Steady State	Maximum
Site Management	1	2	3		
Mining	-	17	17	270	330
Processing	1	89	90		
Maintenance	1	82	83		
SHR	-	8	8	20	28
Environmental	-	6	6		
HR	-	4	4		
Administration	1	23	24		
Corporate Relations	-	2	2		
<b>Total</b>	<b>4</b>	<b>233</b>	<b>237</b>	<b>290</b>	<b>358</b>

In terms of the operating strategy associated with radiation safety, the Project has been designed to, and will comply with, current best practice and, as a minimum, Namibian legislation. This will be reviewed and updated as and when contemporary best practice changes.

At a practical level, this is reflected in the adoption, from conceptual design through to operation and closure, of structured hygiene measures. The most significant of these measures is the incorporation of a “clean side – dirty side” operating strategy. Under this strategy, any employee who comes into contact with uranium-containing material during their duties will be required to change all clothing and footwear prior to entering and leaving the “dirty side” (fenced off or demarcated area that may contain uranium).

For personal use only

# Annexure A (continued)

Tumas Project  
Definitive Feasibility Study Report – Addendum 1  
Chapter 1 – Executive Summary



## 1.18 Marketing

The global nuclear fuel market is undergoing a fundamental change in response to the 24 February 2022 invasion of Ukraine by Russian military forces. The pervasive threat to not only European energy security but also worldwide concerns in response to the Russian invasion has further elevated commercial nuclear power's position within electricity generating technologies. There is a broad-based recognition that nuclear power is an indispensable component of the Net-Zero Carbon scheme, which has only been enhanced by the changing global geo-political environment.

Recent assessments by highly regarded energy analysis organisations, such as the International Energy Agency (**IEA**), have shown that commercial nuclear power is crucial to attain planned Net-Zero Carbon emissions goals. In fact, the IEA has concluded that, without a major contribution from nuclear power, Net-Zero Carbon goals cannot be reached by mid-century.

While the nuclear fuel cycle (natural uranium concentrates ( $U_3O_8$ ), uranium conversion services, enrichment services and fuel fabrication) was poised for significant improvement more than a decade after the Great Eastern Japan Earthquake (Fukushima), the Russian-Ukraine conflict has hastened the evolution of the nuclear fuel industry.

Western nuclear utility dependency on Russian-sourced nuclear fuel, especially in the European Union (including the United Kingdom and Switzerland) as well as North America and significant parts of the Asia/Pacific region, has led to an increasingly recognised “deglobalisation” pivot as utilities seek out more secure sources of nuclear fuel for their growing fleets of nuclear power reactors.

At the present time, the so-called “Western” nuclear fuel market represents a significant majority (about 70-75%) of global nuclear fuel requirements which is highly likely to transition to non-Russian sourced nuclear fuel between now and the latter years of this decade. This will result in escalating pressure on non-Russian fuel sources across the nuclear fuel cycle, including natural uranium concentrates (Russia currently supplies about 14% of global uranium needs).

While forecasts vary based upon underlying assumptions as to the future role of nuclear power in electricity generation, global uranium requirements are expected to expand significantly between now and 2040-2050. According to the World Nuclear Association (**WNA**), the current annual worldwide nuclear reactor industry requires approximately 175.5 Mlbs  $U_3O_8$ . Under the Upper Scenario incorporated in the most recent (2023) WNA analysis and forecast (“Nuclear Fuel Report – Global Scenarios for Demand and Supply Availability 2031-2040”) that total could reach 261.1 Mlbs by 2030 and then accelerate to as much as 479.2 Mlbs by 2040, an increase of almost 275%.

Another crucial market factor has been the longstanding uranium procurement practice by utilities of contracting to purchase natural uranium concentrates under multi-year/long-term agreements principally with primary uranium production suppliers. Recent geo-political events have refocused utility fuel procurement on future supply security through diversification of uranium supply sources favouring politically stable regions and specific countries, including Australia, Canada and Namibia.

For personal use only

## Annexure A (continued)

Tumas Project  
Definitive Feasibility Study Report – Addendum 1  
Chapter 1 – Executive Summary



The Republic of Kazakhstan remains the world's largest producer of natural uranium concentrates. Social unrest in January 2022 requiring the involvement of Russian troops and product transportation challenges with railway shipments across Russia to the Port of St. Petersburg (where most of Kazakh-produced natural uranium is exported to Western uranium conversion facilities) have increased utility concerns regarding over-reliance on Kazakhstan for future uranium sourcing. Moreover, the uranium production sector in Kazakhstan continues to struggle with a shortage of sulfuric acid used to produce uranium concentrates through the application of in-situ recovery technology.

Post-Fukushima, nuclear utilities de-emphasised long-term uranium contracting in favour of supply arrangements which took advantage of low near-term uranium prices. Uranium commitments increasingly focused on a delivery period extending two to four years forward, rather than long-term purchases covering a forward period of up to ten years or more. One result of that underlying coverage strategy has been greater unfilled uranium requirements. Recent forecasts indicate that over the period 2024-2040, global uranium requirements may total an estimated 3.8-3.9 Blbs while slightly more than half (2.1 Blbs) remained uncommitted (yet to be contracted).

Global natural uranium concentrate production has fallen well short of reactor requirements with secondary sources (e.g., inventoried uranium held by commercial entities as well as governments, nuclear fuel reprocessing, weapons-grade uranium being down-blended to commercial grade) supplying the requisite difference. More recently, persistently depressed uranium prices and the dearth of supportive long-term uranium contracting led to reductions in primary production as well as uranium production facilities being placed in care and maintenance status. Then the Covid 19 pandemic resulted in additional operational contractions placing incremental stress on the uranium production sector. Global primary uranium production peaked at 164.3 Mlbs in 2016 but declined to 124.1 Mlbs by 2020, before recovering to an estimated 150-155 Mlb in 2024.

While a limited number of production facilities have announced plans to return to operational status, supply chain issues and lack of qualified personnel and management are expected to result in lengthy lead-times while global cost inflation is impacting needed incentivising uranium prices.

The WNA Nuclear Fuel Report (Upper Scenario) indicates that the global natural uranium market could be brought close to balance for a brief period mid-decade (2025-2026) and then will experience an expanding deficit period when new uranium production facilities are required to support commercial nuclear power programs (refer Figure 22). Sustainable uranium prices in the range of \$70-80 /lb U<sub>3</sub>O<sub>8</sub> are anticipated to be needed to bring forth adequate natural uranium concentrates production.

# Annexure A (continued)

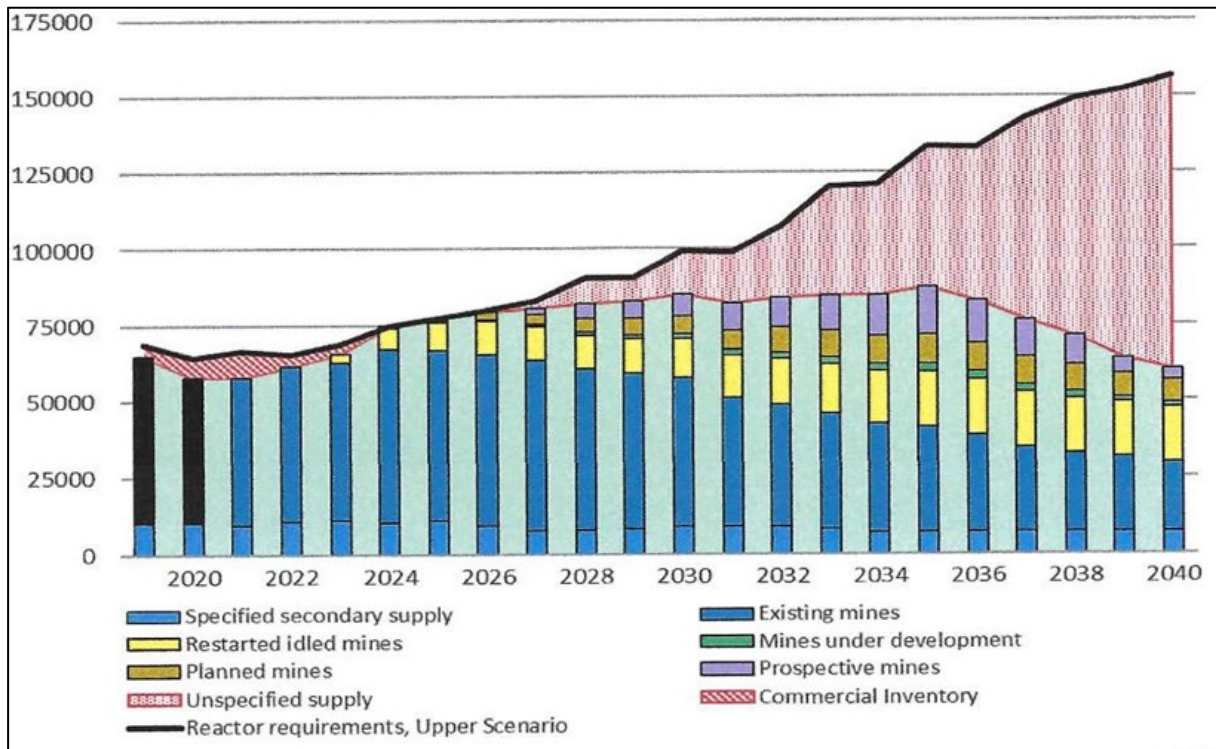

**Figure 22: Reference Scenario Supply, tU.**  
 (World Nuclear Association – The Nuclear Fuel Report 2021).

## 1.19 Financial Analysis

The financial model of the Tumas Project seeks to answer key questions surrounding the value of the Project, the potential variability in cashflows if certain key variables change and the quantum of capital required to put the Project into production. The financial model is constructed using real inputs for costs and prices. These real inputs are escalated by a US dollar inflation index (at 2%/y to generate nominal cashflows and these nominal cashflows are discounted by a nominal discount rate to derive an NPV. The base case U<sub>3</sub>O<sub>8</sub> price is based on the TradeTech Forward Availability Model – 2 issue 4 (**FAM-2**) (real) pricing (a constant \$82.50 is used as a downside case and \$110/lb as an upside case) over the life of the model (from 2040 onward, the extent of the FAM-2 forward forecast, the price is assumed to be flat until the end of the operation), which means that, in nominal terms, it rises each period with inflation. The treatment of pricing and costs is identical in this respect. Model results are presented in real (un-escalated) terms unless otherwise stated.

The model has been constructed by an independent expert in financial modelling, based on inputs and assumptions provided by Ausenco, Deep Yellow and various other technical consultants associated with the Project.

The model is constructed in quarters with cashflows in US dollars and has the provision for foreign currency sensitivity analysis.

For personal use only

## Annexure A (continued)

Tumas Project  
Definitive Feasibility Study Report – Addendum 1  
Chapter 1 – Executive Summary



The Project is demonstrated to be financially robust and key financial parameters are detailed in Table 16 at each of the price points indicated above. The table also provides the DFS Re-Price model (\$75/lb U<sub>3</sub>O<sub>8</sub> base case) output for reference.

**Table 16: Key Financial Parameters.**

Project Financials (Ung geared): Real unless stated	Unit	LOM			
		DFS Re-Price \$75/lb	\$82.50/lb	FAM 2	\$110/lb
U <sub>3</sub> O <sub>8</sub> Gross Revenue	\$ M	4,788	6,041	7,609	8,055
Gross Revenue: Total	\$ M	4,950	6,146	7,714	8,160
Site Operating Costs (during Production)	\$ M	(2,263)	(2,911)	(2,911)	(2,911)
Namibian State Royalty & Export Levy	\$ M	(160)	(198)	(249)	(264)
Cash Operating Margin	\$ M	2,463	2,963	4,480	4,911
Initial Capex (excl. Pre-Production Operating costs)	\$ M	(361)	(452)	(452)	(452)
Initial Capex (incl. Pre-Production Operating costs)	\$ M	(412)	(474)	(474)	(474)
Sustaining Capex and Closure	\$ M	(95)	(192)	(192)	(192)
Total Capital, Sustaining Capital & Pre-Production Operating Costs	\$ M	(532)	(667)	(667)	(667)
Movement in Working Capital	\$ M	4.2	6.8	4.3	3.6
Undiscounted Cashflow Pre-Tax	\$ M	1,935	2,304	3,817	4,248
Tax Payable	\$ M	(722)	(857)	(1,424)	(1,585)
Undiscounted Cashflow After Tax	\$ M	1,213	1,446	2,393	2,663
C1 Cost (U <sub>3</sub> O <sub>8</sub> basis with V <sub>2</sub> O <sub>5</sub> by-product)	\$/lb	34.35	38.70	38.71	38.72
All-in-Sustaining-Cost (U <sub>3</sub> O <sub>8</sub> basis with V <sub>2</sub> O <sub>5</sub> by-product)	\$/lb	38.63	44.52	45.23	45.43
Project NPV (Post Tax)	\$ M	570	577	972	1,153
Project IRR (Post Tax): Nominal	%	27%	19%	22%	29%
Project Payback Period from Construction Start (Nominal)	Years	5	6	5	5
Project Payback Period from Production Start (Nominal)	Years	3	4	3	3
Maximum Project Drawdown (Nominal)	\$ M	407	492	490	487
Maximum Project Drawdown	\$ M	400	479	477	474

For personal use only

# Annexure A (continued)



At \$82.50 /lb, the project materially meets (slightly under on IRR) all the Deep Yellow project development criteria. Under the FAM-2 base case price deck, the project is demonstrated to be both robust and of long operating life.

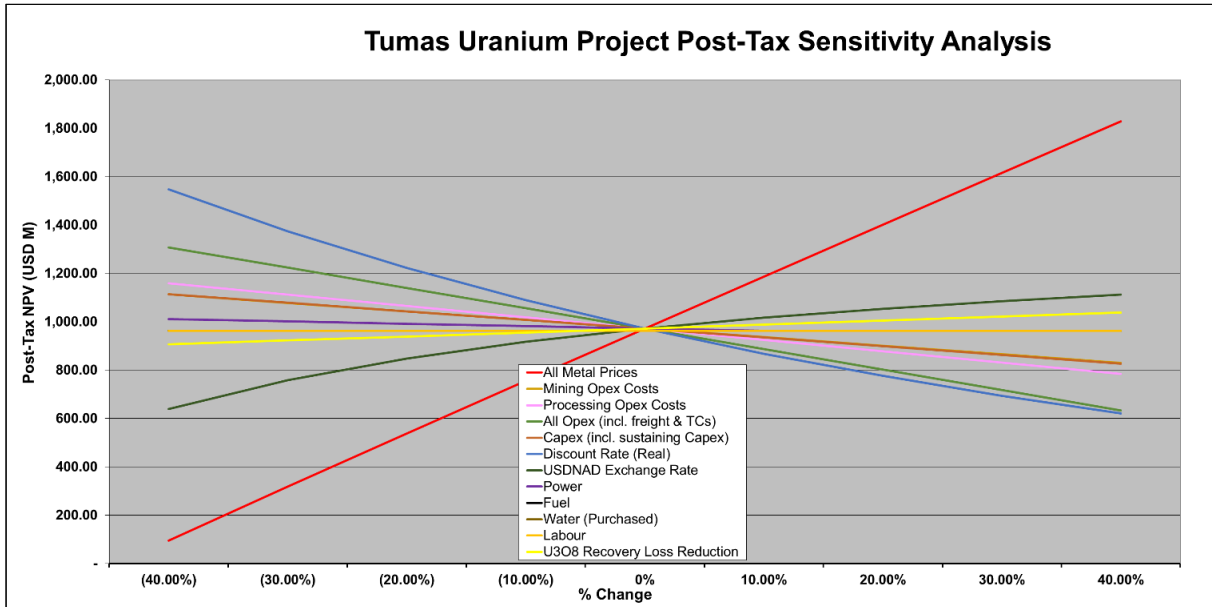

Figure 23: Tumas Project Sensitivity Spider Chart.

The project is demonstrated to be most sensitive to uranium prices and relatively insensitive to other elements examined. Risk in the Project may consequently be reduced most effectively by securing long-term offtake agreements for uranium production on suitable terms.

## 1.20 Project Finance

The funding structure to be adopted for the Tumas Project will be one of project financing to minimise risk to the project, maintaining flexibility and preserving shareholder value. Deep Yellow anticipates that a project finance loan implemented in today’s market would attract a total borrowing rate of between 8% to 10%, though the final cost will be dependent on whether global inflationary pressures are contained.

The Deep Yellow team responsible for implementing the project finance facility for the Tumas Project are the same team who previously implemented the project financing for the development of the Kayelekera Uranium Project in Malawi and the Langer Heinrich Uranium Project in Namibia. Both financings involved a number of international banks and, for the financing of the Kayelekera Uranium Project, the involvement of the Export Credit Insurance Corporation of South Africa.

## 1.21 Risk

Effective risk management is integral to the capital investment cycle, from evaluation of a business development opportunity through feasibility, project execution, operations and, ultimately, closure and rehabilitation. A structured and thorough understanding of the key risks of the investment allows the project team to focus their attention and better allocate resources.

For personal use only

## Annexure A (continued)

Tumas Project  
Definitive Feasibility Study Report – Addendum 1  
Chapter 1 – Executive Summary



The objective of the risk management process applied during the Tumas Feasibility Study was to identify risks that could prevent the Project from achieving its strategic, business and operational objectives. In the context of a feasibility study, objectives are defined as delivering a safe, economic and executable project outcome.

During the process development process (Chapter 11), efforts were made to identify and either remove or mitigate potential risks. The walkaway rehabilitation strategy, a key factor in the design process, was developed specifically to mitigate the potential long term environmental impacts of the Project and to facilitate the EIA approval process.

Risk assessment and management during this study encompassed the following analysis of risk:

project risks, consisting of the identification of threats that could materially impact the achievement of the project objectives and the development of the associated management plans;

- technical and operational risks, to inform preliminary engineering and to address the safety, environmental and operability of the facilities; and
- a quantitative risk analysis, conducted as part of the capital cost estimate development process, to determine the project cost contingency and the float for the execution schedule.

A hazard identification (**HAZID**) exercise was undertaken to identify engineering design issues to be addressed during the detailed design phase of the Project.

Risk management is a dynamic and continuous process that is performed over the full lifecycle of a project, from scoping to execution. Consequently, the data and information presented in this report is a snapshot of the project risk profile as understood in March 2025. As the risk management process is continuous, risks currently remain open on the risk register and will be addressed in subsequent project phases.

Particular attention to risk management is required throughout the project definition, design, execution and hand-over to operations. By identifying threats (and opportunities) and their causes and understanding the required risk controls, it can be ensured that, if the risks cannot be eliminated, they are at least controlled so they are As Low As is Reasonably Practicable (**ALARP**).

The purpose of the Risk Management section of the Definitive Feasibility Study (**DFS**) report is to provide an overview of the identified event risk and opportunity profile for the project and to outline the approach the project team intends to take to ensure these risks are appropriately managed to support Deep Yellow Limited (**DYL**) core values.

The Tumas DFS risk assessment has identified a broad spectrum of hazards and opportunities that provide a representative series of scenarios, which accurately and robustly portray the current risk profile for the project. The overall Feasibility Study risk profile is shown in Figure 24 which summaries the qualitative scale of risk for each type of Impact, while details the number of scenarios in each impact category. As can be seen in Figure 1 the overall risk profile is currently dominated by Project Delivery and Operational Performance related issues, which is to be expected of project of this type and stage.

# Annexure A (continued)

**Table 17: Residual Risk Ratings.**

Risk	Financial	Revenue	Project	HSES	External	Total
<b>Extreme</b>	0	0	0	0	0	0
<b>High</b>	4	2	1	0	0	7
<b>Moderate</b>	2	7	23	8	4	44
<b>Low</b>	1	0	0	0	2	3
<b>Total</b>	<b>7</b>	<b>9</b>	<b>24</b>	<b>8</b>	<b>6</b>	<b>54</b>

**Table 1 # Risk Events for Tumas Feasibility Stage Study**

Project = Design, Project Delivery, technical  
 Revenue = Operational Performances  
 HSES = Health, Safety, Environmental and Radiation  
 External = Reputation, Legal and Community

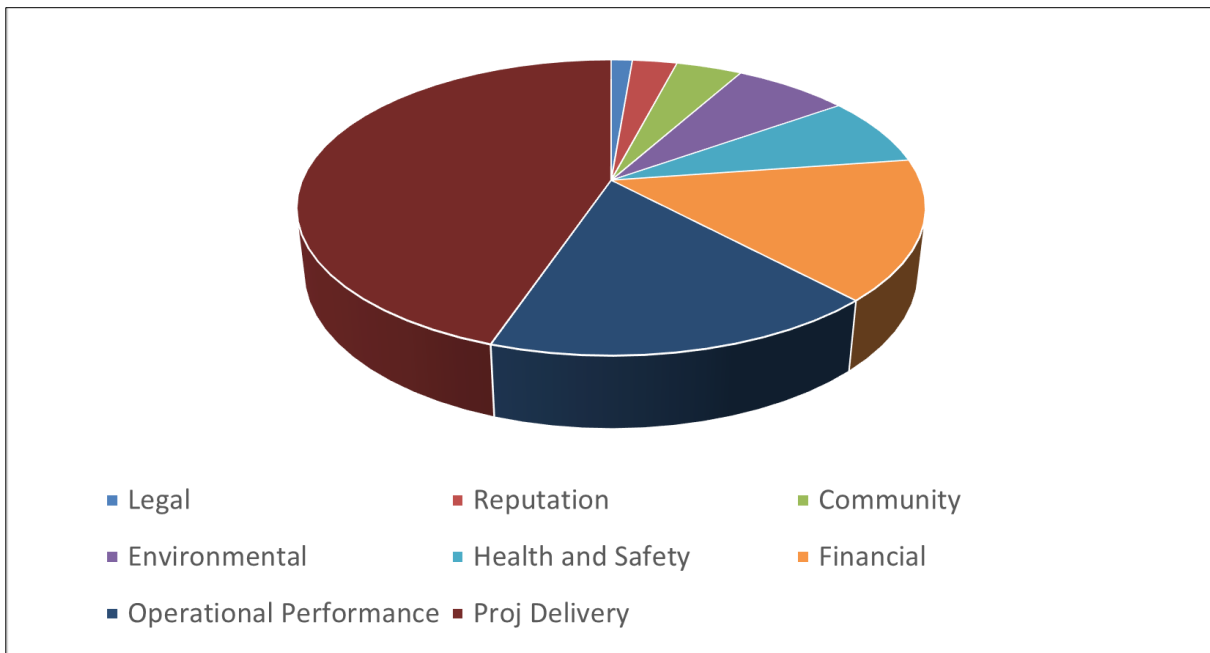

**Figure 24: Qualitative Scale of Risk by Impact.**

Whilst a number of the risks identified in the DFS risk review are common to most large mining projects at the Feasibility stage (exceeding CAPEX, External influences, etc.) this is in part due to the stage of the project and as the specific project control regimes that will be applied to ameliorate the risks will only be fully developed in the subsequent execution phases of the project. For all 54-events identified Feasibility risk issues, the existing controls and those that will be implemented during the study/ execution/ operations phases, are broadly defined in the Feasibility risk register and will be enhanced as the register is revisited through the project delivery and into operations. These controls are predicted to be appropriate for the further reduction of the risk. Ongoing effort will be required to ensure delivery of all required controls to achieve ALARP.

For personal use only

## Annexure A (continued)

During the project’s development, all efforts have been made to identify and either remove or mitigate potential risks. For example, the walkaway rehabilitation strategy, a key factor in the design process, was developed specifically to mitigate the potential long-term environmental impacts of the Project and to facilitate the EIA approval process.

While it is clear there is still considerable risk assessment work yet to be undertaken through the development of the Project, there are no current risk issues that have been identified that are considered insurmountable or that will prevent the Project from being delivered in an acceptable manner. Albeit the 7-project viability risks area will require specific focus.

Overall, it is apparent the risk that the Project progressing to execution does not deliver value to the owners is modest, given the required investment and potential returns (including identified opportunities), which outweigh the downside risks associated with the study phases. This risk will need to continue to be reviewed at benefit computation to the key project stages.

While the current risk profile has a significant degree of uncertainty within it, the predominant issues seen as potential threats to project viability are as detailed in table XX (these are effectively rolled-up from the 54 risks in the Tumas Definitive Feasibility Stage risk register) and then specifically discussed in Table XXX.

**Table 18: Risks to the Tumas Feasibility Project Viability.**

Risk Area	Risk
Sustainability	Project as delivered (execution and into operations) fails to meet DYL Health, Safety, Environmental and Radiation expectations.
Financial	Project CAPEX/ OPEX impact the project profitability
Financial	Project as delivered does not achieve the planned sales product (Quality/ Quality/ Timing)
Financial	External influences adversely impacting the Project
Project Delivery	Delays to Project hand-over to Operations
Reputational	Project impact on National Park
Financial	Uncertainty with the Orebody (Geological-Metallurgical model)

The DFS risk and opportunity workshops were conducted in November 2024 and again on 20 March 2025 with the primary objective(s) to support the project in:

- the identification of the material hazards and opportunities associated with developing the Tumas mining and haulage operation;
- understanding the nature of the risks to the project faces from these hazards and opportunities; and
- developing appropriate control strategies that can be embedded from an early stage into the project.

## Annexure A (continued)

Tumas Project  
Definitive Feasibility Study Report – Addendum 1  
Chapter 1 – Executive Summary



The Tumas DFS risk workshops adopted the DYL risk management processes and were independently facilitated. The workshops were attended by a wide range of key project personnel and formally recorded. The developed risk profile provides a top-down perspective of the risk and defines the controls (already programmed or new) to be applied going forward and to inform the project authorisation process. The relevant bottom-up risk perspective will be developed separately during the project execution via the range of subsequent risk activities that will be developed separately.

As this was a project level risk review, issues associated with the specific aspects of the detailed design packages and operations of the completed project deliverables were not specifically assessed. Separate Safety in Design/ Risk management activities have been conducted throughout the DFS (and earlier) project phases to address these aspects as follows:

- technical and operational risk reviews, to inform preliminary engineering and to address the safety, environmental and operability of the conceptual facilities;
- project risk reviews, consisting of analysis to identify threats that could materially impact the achievement of the project objectives and development of associated management plans; and
- a quantitative risk analysis was conducted to determine the project cost contingency and the float for the execution schedule.

The identification of potential future opportunities was excluded from this review as all opportunities are assessed when identified during the course of the study and implemented immediately if appropriate.

For personal use only

# Annexure B

JORC Tables



## JORC Mineral Resources – Namibia

Deposit	Category	Cut-off (ppm U <sub>3</sub> O <sub>8</sub> )	Tonnes (M)	U <sub>3</sub> O <sub>8</sub> (ppm)	U <sub>3</sub> O <sub>8</sub> (t)	U <sub>3</sub> O <sub>8</sub> (Mlb)	Resource Categories (Mlb U <sub>3</sub> O <sub>8</sub> )		
							Measured	Indicated	Inferred
<b>BASEMENT MINERALISATION</b>									
<b>Omahola Project – JORC 2012<sup>1</sup></b>									
INCA Deposit ♦	Indicated	100	21.4	260	5,600	12.3	-	12.3	-
INCA Deposit ♦	Inferred	100	15.2	290	4,400	9.7	-	-	9.7
Ongolo Deposit #	Measured	100	47.7	185	8,900	19.7	19.7	-	-
Ongolo Deposit #	Indicated	100	85.4	170	14,300	31.7	-	31.7	-
Ongolo Deposit #	Inferred	100	94.0	175	16,400	36.3	-	-	36.3
MS7 Deposit #	Measured	100	18.6	220	4,100	9.1	9.1	-	-
MS7 Deposit #	Indicated	100	7.2	185	1,300	2.9	-	2.9	-
MS7 Deposit #	Inferred	100	8.7	190	1,600	3.7	-	-	3.7
<b>Omahola Project Sub-Total</b>			<b>298.2</b>	<b>190</b>	<b>56,500</b>	<b>125.4</b>	<b>28.8</b>	<b>46.9</b>	<b>49.7</b>
<b>CALCRETE MINERALISATION</b>									
<b>Tumas 3 Deposit - JORC 2012<sup>2</sup></b>									
Tumas 3 Deposit	Measured	100	33.3	300	10,210	22.5	22.5	-	-
	Indicated	100	48.6	335	16,200	35.7	-	35.7	-
	Inferred	100	16.1	170	2,770	6.1	-	-	6.1
<b>Tumas 3 Deposits Total</b>			<b>98.5</b>	<b>295</b>	<b>29,180</b>	<b>64.3</b>			
<b>Tumas 1, 1 East and 2 Project – JORC 2012<sup>3,4</sup></b>									
Tumas 1, 1 East and 2 Deposit ♦	Measured	100	35.2	205	7,270	16.0	16.0	-	-
Tumas 1, 1 East and 2 Deposit ♦	Indicated	100	55.2	230	12,640	27.9	-	27.9	-
Tumas 1, 1 East and 2 Deposit ♦	Inferred	100	21.2	215	4,530	10.0	-	-	10.0
<b>Tumas 1, 1 East &amp; 2 Deposits Total</b>			<b>111.6</b>	<b>220</b>	<b>24,430</b>	<b>53.9</b>			
<b>Sub-Total of Tumas 1, 1 East, 2 and 3</b>			<b>210.1</b>	<b>255</b>	<b>53,610</b>	<b>118.2</b>	<b>38.5</b>	<b>63.6</b>	<b>16.1</b>
<b>Tubas Red Sand Project - JORC 2012<sup>5</sup></b>									
Tubas Sand Deposit #	Indicated	100	10.0	185	1,900	4.1	-	4.1	-
Tubas Sand Deposit #	Inferred	100	24.0	165	3,900	8.6	-	-	8.6
<b>Tubas Red Sand Project Total</b>			<b>34.0</b>	<b>170</b>	<b>5,800</b>	<b>12.7</b>			
<b>Tubas Calcrete Resource - JORC 2004<sup>6</sup></b>									
Tubas Calcrete Deposit	Inferred	100	7.4	375	2,765	6.1	-	-	6.1
<b>Tubas Calcrete Total</b>			<b>7.4</b>	<b>375</b>	<b>2,765</b>	<b>6.1</b>			
<b>Aussinanis Project - JORC 2012- DYL 85%<sup>7</sup></b>									
Aussinanis Deposit ♦	Indicated	100	12.3	170	2,000	4.5	-	4.5	-
Aussinanis Deposit ♦	Inferred	100	62.1	170	10,700	23.6	-	-	23.6
<b>Aussinanis Project Total</b>			<b>74.4</b>	<b>170</b>	<b>12,700</b>	<b>28.1</b>			
<b>Calcrete Projects Sub-Total</b>			<b>325.9</b>	<b>230</b>	<b>74,875</b>	<b>165.1</b>	<b>38.5</b>	<b>72.2</b>	<b>54.4</b>
<b>Grand Total Namibian Resources</b>			<b>624.1</b>	<b>210</b>	<b>131,475</b>	<b>290.5</b>	<b>67.3</b>	<b>119.1</b>	<b>104.1</b>

**Notes:**

- Figures have been rounded and totals may reflect small rounding errors.
  - XRF chemical analysis unless annotated otherwise.
  - # Combined XRF Fusion Chemical Assays and eU<sub>3</sub>O<sub>8</sub> values.
  - ♦ eU<sub>3</sub>O<sub>8</sub> - equivalent uranium grade as determined by downhole gamma logging.
  - Where eU<sub>3</sub>O<sub>8</sub> values are reported it relates to values attained from radiometrically logging boreholes.
  - Gamma probes were originally calibrated at Pelindaba, South Africa in 2007. Recent calibrations were carried out at the Langer Heinrich Mine calibration facility in July 2018, September 2019, December 2020, January 2022, February 2023 and August 2024.
  - Sensitivity checks are conducted by periodic re-logging of a test hole to confirm operations.
  - During drilling, probes are checked daily against standard source.
1. ASX release 4 November 2021 'Omahola Basement Project Resource Upgrade to JORC 2012'.
  2. ASX release 11 September 2024 'Tumas 3 Drilling Achieves Measured Resource Target'.
  3. ASX release 2 September 2021 'Tumas Delivers Impressive Indicated Mineral Resource'.
  4. ASX release 11 September 2024 'Tumas 3 Drilling Achieves Measured Resource Target'.
  5. ASX release 24 March 2014 'Tubas Sands Project – Resource Update'.
  6. ASX release 28 February 2012 'TRS Project Resources Increased'.
  7. ASX release 31 March 2023 'Aussinanis Project Resource Upgrade to JORC (2012)'.

# Annexure B (continued)

JORC Tables



## JORC Ore Reserves - Namibia

Deposit	Category	Cut-off (ppm U <sub>3</sub> O <sub>8</sub> )	Tonnes (M)	U <sub>3</sub> O <sub>8</sub> (ppm)	U <sub>3</sub> O <sub>8</sub> (t)	U <sub>3</sub> O <sub>8</sub> (Mlb)	Reserve Categories (Mlb U <sub>3</sub> O <sub>8</sub> )	
							Proved	Probable
<b>NAMIBIA</b>								
<b>Tumas Project - JORC 2012<sup>1</sup></b>								
Tumas 3	Proved	100	21.0	357	7,500	16.6	16.6	
Tumas 3	Probable	100	30.3	398	12,060	26.6		26.6
Tumas 1 and 2	Proved	100	23.7	227	5,380	11.9	11.9	
Tumas 1 and 2	Probable	100	10.1	238	2,400	5.4		5.4
Tumas 1 East	Probable	100	35.0	246	8,610	19.0		19.0
<b>Tumas Project</b>		<b>100</b>	<b>120.1</b>	<b>298</b>	<b>35,950</b>	<b>79.3</b>	<b>28.5</b>	<b>51.0</b>

**Notes:**

- Figures have been rounded and totals may reflect small rounding errors.

<sup>1</sup>. ASX release 18 December 2024; 2 Feb 2023 'Strong Results From Tumas Definitive Feasibility Study'.

For personal use only