

24 July 2025

KANMANTOO MT SURVEY IDENTIFIES ALTERATION TARGETS

- A Magnetotelluric (MT) survey has been completed on the Kanmantoo exploration lease, with the survey covering the Southern and Eastern margins of the deposit.
- Highlights of the survey includes:
 - A conductivity zone continuing to a depth of over 2km below surface and extending to the South beyond Emily Star
 - A steep zone of high conductivity beneath the area of known mineralisation consistent with the dip observed in mineralisation in the underground mine
- Emily Star depth extensions will be targeted in September 2025.

Commenting on the exploration geophysical survey results, Hillgrove CEO and Managing Director, Bob Fulker said:

“Our first geophysical survey of the year has delivered very encouraging results, highlighting a continuation of the alteration system to depths of 2 km as well as an extension to the South of existing known mineralisation. This new data, obtained through the MT survey, will directly inform and refine our drill targeting for our upcoming Resource expansion drilling.

The first of these tests that we will be conducting is to target the depth extensions towards the Emily Star deposit in September 2025, focusing on the southern end of the surveyed area. This area currently has a Resource of 2.6 million tonnes at 0.77% copper and 0.08g/t gold¹. This initial drilling is looking to grow this Resource and improve our understanding of mineralisation distribution – with the ultimate aim of bringing the deposit online as a separate area to our existing Kavanagh, Spitfire, and soon to be Nugent deposits.

As part of our strategy to seek opportunities to organically grow our production profile, areas such as Emily Star are important for us – as it provides an independent mining area for additional mining inventory to increase the utilisation of Kanmantoo’s 3.6Mtpa processing plant.

We’ve greatly valued the collaboration with Fleet Space Technologies on this survey, which has significantly advanced our understanding of the broader Kanmantoo mineral system.

Looking ahead, planning is now underway for our next geophysical survey in the South Eastern Tenement Area, scheduled for the September quarter of 2025.”

¹ Refer ASX announcement of 18 October 2024

Hillgrove Resources Limited ('Hillgrove', 'the Company') (ASX:HGO) is pleased to provide the following geophysical update from the Kanmantoo Deposit. A Magnetotelluric² (MT) survey has been completed on site at Kanmantoo by Fleet Space Technologies with the survey covering the Southern and Eastern margins of the deposit across both the EL6526 and ML6345. The MT Survey uses the conductivity variation as a proxy for areas of alteration. It is within the high conductivity zones that alteration of the regional host rocks is inferred. At Kanmantoo it is within this alteration corridor that the Copper Gold mineralisation is observed to overprint the alteration mineral assemblages.

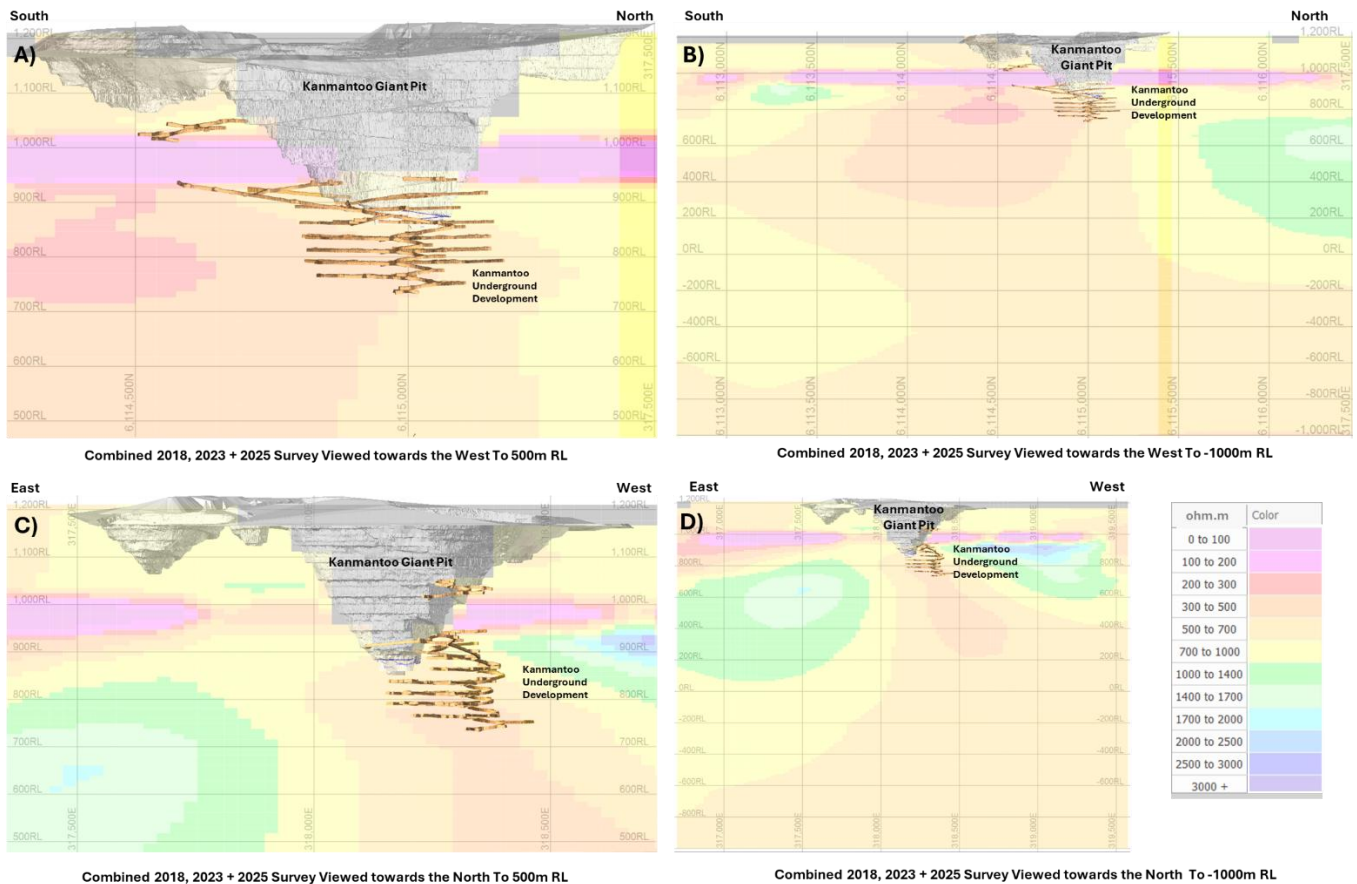

Figure 1: Sectional Images of the Completed MT Survey Results. Images A + C show the MT Model zoomed to the Kanmantoo Mine Area (500m RL). B + D show the MT model to -1000m RL (model extents). Mine RL is ASL (Above Sea Level) +1000m

The 2025 MT Survey was designed to overlap with both the 2018/2019 and 2023 MT surveys to allow the data to be processed into one overarching model. This also allowed for the model to be validated against the previous results to provide a deposit scale model. The western side of the model is poorly constrained due to no survey points along this side of the corridor.

² Magnetotellurics (MT) and Audio-frequency MT (AMT) are electro-magnetic survey and imaging techniques that use naturally-occurring ionospheric current sheets and lightning storms — passive energy sources — to map geologic structures to depths of 1500 meters or more.

For personal use only

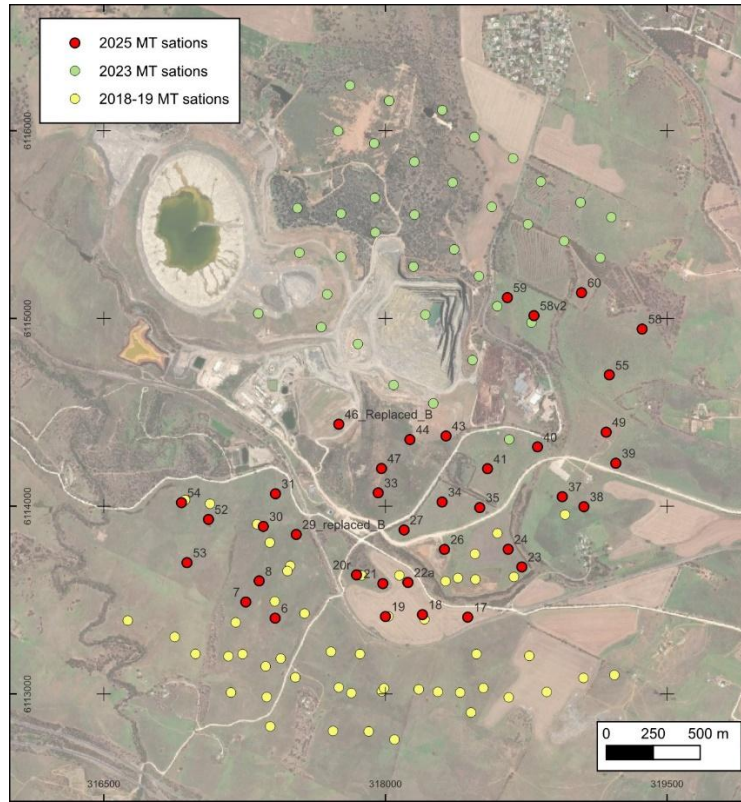

Figure 2: MT Survey Area

The model produced from the MT data shows a number of key conductive areas that align to the known alteration corridor of the deposit. Also observed in the data is a shallower resistive area south of the Kanmantoo Giant Pit, resulting in the conductive zone extending further to the south than observed in previous surveys. The high conductivity area also extends down to a depth of over 2km from surface with the geometry (dip and plunge) of the conductive zone consistent with the observed shear corridor that hosts the copper gold mineralisation.

The information collected during this survey has provided guidance on the shape and scale of the alteration corridor. The geological interpretation of the alteration will be used in the design of resource expansion drilling as the location of the alteration corridor assists in providing a vector to identify the shear corridor where mineralisation is observed.

For personal use only

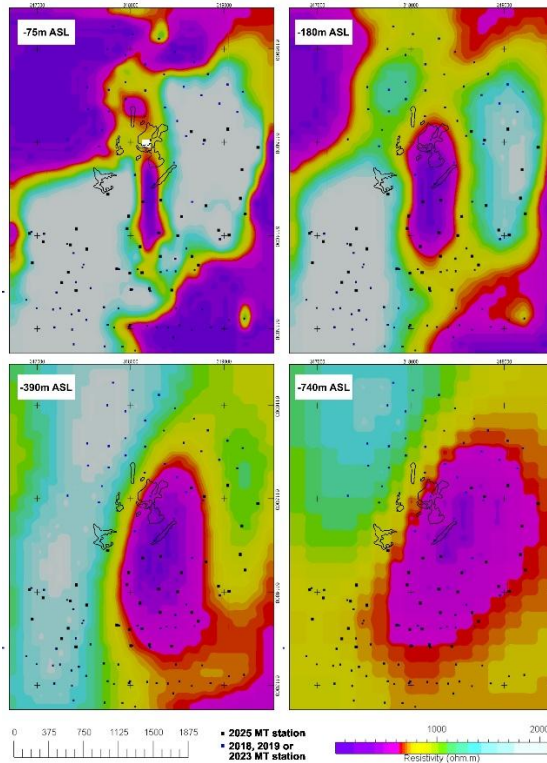

Figure 3: MT Model in plan sliced by level below surface (ASL)

Drilling to target Emily Star from the Nugent area is planned in Q3. This drilling will also target the southern end of the high conductive zone of the MT survey which corresponds to the area along strike of Paringa and Critchley.

Further, this drilling from underground is on track for the planned Mineral Resource update in Q4 2025 with an additional 48,000m of diamond drilling completed to the end of June 2025 to be included in the update.

Authorised for release by the Board of Hillgrove Resources Limited.

For more information contact:

Mr Bob Fulker
CEO & Managing Director
Tel: +61 (0)8 7070 1698

Mr Luke Anderson
Chief Financial Officer
Tel: +61 (0)8 7070 1698

Competent Person's Statement

The information in this release that relates to the Exploration Results is based upon information compiled by Caitlin Rowett, who is a Member of The Australasian Institute of Mining and Metallurgy. Caitlin Rowett is a full-time employee and holds equity in Hillgrove Resources Limited and has sufficient experience relevant to the styles of mineralisation and type of deposit under consideration to qualify as a Competent Person as defined in the 2012 Edition of the 'Australasian Code for Reporting of Exploration Results, Mineral Resources and Ore Reserves (JORC Code)'. Caitlin Rowett has consented to the inclusion in the release of the matters based on their information in the form and context in which it appears.

The information in this report that relates to the 2024 Kanmantoo Mineral Resource Estimate is extracted from ASX release titled 'Maiden Kanmantoo Underground Ore Reserve and 96% Increase in Copper Mineral Resource Endowment' dated 18 October 2024 and is available to view at www.hillgroveresources.com.au. The Company confirms that it is not aware of any new information or data that materially affects the information included in the original market announcement and that all material assumptions and technical parameters underpinning the Mineral Resource Estimate in the relevant market announcement continue to apply and have not materially changed. The Company confirms that the form and context in which the Competent Person's findings are presented have not been materially modified from the original market announcements.

Forward Looking Statement

This Report contains or may contain certain forward-looking statements and comments about future events, that are based on Hillgrove's beliefs, assumptions and expectations and on information currently available to management as at the date of this presentation. Often, but not always, forward-looking statements can generally be identified by the use of forward-looking words such as "may", "will", "expect", "plan", "believes", "estimate", "anticipate", "outlook", and "guidance", or similar expressions, and may include, without limitation, statements regarding plans, strategies and objectives of management, anticipated production and production potential, financial forecasts, product quality estimates of future Mineral Resources and Ore Reserves. Such statements are only expectations or beliefs and are subject to inherent risks and uncertainties which could cause actual values, results or performance achievements to differ materially from those expressed or implied in this announcement. Where Hillgrove expresses or implies an expectation or belief as to future events or results, such expectation or belief is expressed in good faith and on a reasonable basis. No representation or warranty, express or implied, is made by Hillgrove that the matters stated in this presentation will in fact be achieved or prove to be correct. Except as required by law, Hillgrove undertakes no obligation to provide any additional or updated information or update any forward-looking statements whether on a result of new information, future events, results or otherwise. Readers are cautioned against placing undue reliance on forward-looking statements. These forward-looking statements are not guarantees of future performance and involve known and unknown risks, uncertainties, assumptions and other important factors, many of which are beyond the control of Hillgrove, the directors, and management of Hillgrove. These factors include, but are not limited to difficulties in forecasting expected production quantities, the potential that any of Hillgrove's projects may experience technical, geological, metallurgical and mechanical problems, changes in market prices and other risks not anticipated by Hillgrove, changes in exchange rate assumptions, changes in product pricing assumptions, major changes in mine plans and/or resources, changes in equipment life or capability, emergence of previously underestimated technical challenges, increased costs, and demand for production inputs.

APPENDIX A – JORC Table 1

Section 1 Sampling Techniques and Data

Criteria	Commentary
Sampling techniques	The resistivity responses have been sampled with AMT/MT technology by a competent user of the technology with more than 10 years experience in this field. The 2025 the 3D MT grid has 40 stations ~250 metres apart and every station recorded for an average of 12 Hours. After a review of the quality of data for every station the depth of the inversion model was restricted to 2000 metres below surface. The 2025 MT data was merged with the previously collected 2023 + 2018 2D MT data set before inversion. The 3D inversion is via Fleet's internal MT inversion based on SimPeg. Model is reported in ohm.m
Drilling techniques	No new drilling reported so not applicable
Drill sample recovery	Not applicable
Logging	Fleet Space in conjunction with Zonge used the most recent Phoenix MT systems and coil magnetometers with satellite connectivity to log the resistivity responses. The diagram below shows the approximate layout of field sites for the MT stations

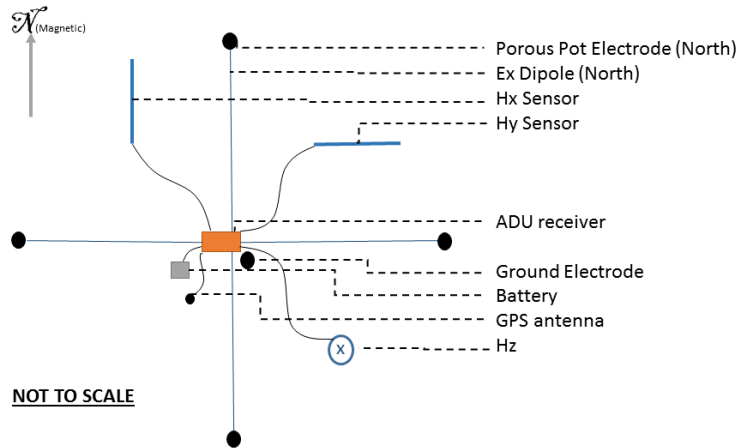

Sub-sampling techniques and sample preparation

Not applicable

Quality of assay data and laboratory tests

Not applicable

Verification of sampling and assaying

MT base station located in an area of “quiet” electromagnetic noise approximately 10 kms North West of the gridded area.

Location of data points

The map projection of Map Grid of Australia 1994 - Zone 54, (MGA94-54) was used.

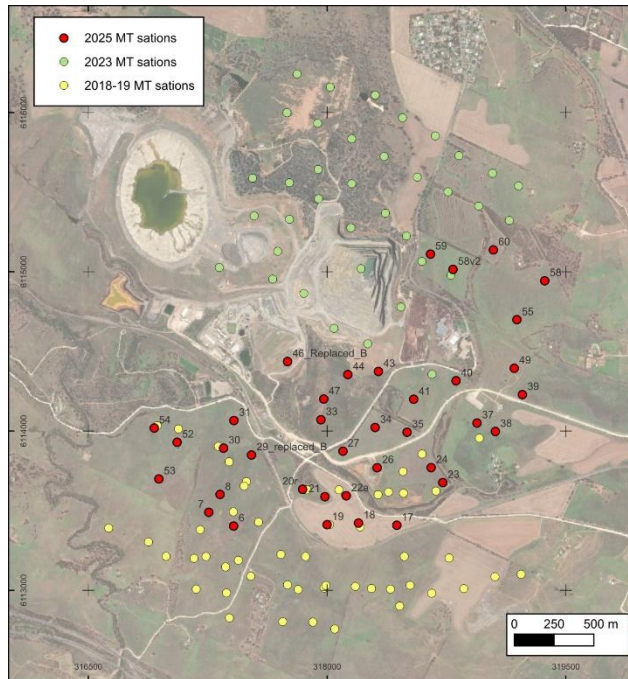

	<p>MT sample locations are shown in above image. The red pins are the 2025 MT data points.</p> <p>MT Sample locations recorded by hand held GPS and elevations from LIDAR topographic survey.</p>
Data spacing and distribution	As shown above
Orientation of data in relation to geological structure	<p>The 2025 MT survey was orientated in a staggered grid over the southern and eastern margin of the known Kanmantoo Deposit</p> <p>The 2018 2D lines were oriented at ~100deg east west, normal to the strike of the Kavanagh Cu zone</p> <p>The 2023 MT survey was a staggered grid over the area of interest as shown above</p> <p>The MT inversion grid is oriented to be normal to the average strike of the Kanmantoo Cu-Au mineralisation.</p>
Sample security	All data electronically despatched to the office of the sub-contractor each evening
Audits or reviews	No audits of Fleet Spaces/Zonge activities or inversion parameters.

Section 2 Reporting of Exploration Results

Criteria	Commentary
Mineral tenement and land tenure status	<p>The Kanmantoo Cu-Au mine is situated on Mining Lease ML6345 + ML6436 and is owned 100% by Hillgrove Resources Limited (HGO).</p> <p>HGO owns the land covered by the Mining Lease. The Mine Lease is encompassed on all sides by EL6526 also owned 100% by Hillgrove Resources. Surveys were completed on land owned by Hillgrove Resources.</p>
Exploration done by other parties	Hillgrove Resources commenced exploration drilling in 2004 and since then has completed a number of exploration sampling, mapping and geophysical campaigns which have resulted in defining the targets.

Geology	Mineralisation occurs as an epigenetic system of structurally controlled veins and disseminations of chalcopyrite, pyrrhotite, pyrite, magnetite, within a quartz + biotite + andalusite ± garnet ± chlorite +/- staurolite schist host rock. Structural studies suggest the mineralisation is within brittle structures that have been re-activated. Due to the sustained period of deformation there are different phases of alteration and mineralisation.
Drill hole Information	No new drill holes are quoted in this release.
Data aggregation methods	No data aggregation or equivalent calculations
Mineralisation widths	No new intersections reported in this release.
Diagrams	Diagrams that are relevant to this release have been included in the body of the release.
Balanced reporting	All MT Survey data has been reviewed in the generation of this release and compared to existing geological and geophysical models
Other exploration data	Information collected has been reviewed against existing drillhole information and previously completed MT surveys.
Further work	Geological interpretation of the results will be used to generate drilling targets