

REBECCA-ROE GOLD PROJECT DEFINITIVE FEASIBILITY STUDY

Ramelius Resources Limited (ASX: RMS) ("Ramelius", "the Company") is pleased to announce the results of its Rebecca-Roe Gold Project Definitive Feasibility Study (DFS).

Highlights

- **Undiscounted cash flow, after tax, of A\$1,037M** (at a base case of A\$4,500/oz)
- **After-tax net present value (NPV_{5%}) of A\$692M** (at A\$4,500/oz)
- Internal rate of return (**IRR**) **after tax of 34%** (at A\$4,500/oz)
- Gold production averages **130koz pa over the Life-of-Mine at an AISC of A\$2,625/oz**
- Mine Plan¹
 - A gold price of A\$3,250/oz has been used for generation of open pit and underground cut-off grades
 - Open Pit - 21Mt at 1.3g/t for 0.88Moz
 - Underground - 5Mt at 1.8g/t for 0.31Moz
 - **Total - 26Mt at 1.4g/t for 1.2Moz**
 - Mining commencement December 2027 Quarter, with first gold production forecasted to commence in the December 2028 Quarter, with an initial mine life of nine (9) years
 - Capital cost of A\$188M for a 3.25Mtpa processing plant located adjacent to Rebecca
 - Average metallurgical recovery of 91.5%
- Ore Reserve²
 - Open Pit - 21Mt at 1.3g/t Au for 0.88Moz
 - Underground - 4.4Mt at 1.8g/t Au for 0.26Moz
 - **Total - 25Mt at 1.4g/t At for 1.1Moz**
 - **Maiden Bombora (Roe) Underground Ore Reserve** following the completion of geotechnical and hydrology work required for conversion
- **Financial Investment Decision (FID) obtained from the Ramelius Board** based on the underlying DFS economics, subject to environmental permitting for Roe (Rebecca approval already in place)
- **Early Works of A\$25M in FY26** including approximately A\$12M for the purchase of 40,000 put options priced at A\$5,750/oz in FY28. The underlying hedge representing the value of the Rebecca-Roe processing plant spend in FY28
- Development of the Rebecca-Roe Gold Project will be **fully funded by Company cash reserves**
- Key focus areas:
 - Referral of Roe Project to Environmental Protection Authority (EPA) – December 2025;
 - Completion of Native Title Mining Agreement and granting of associated tenure; and
 - Tendering of Early Works contracts such as the airstrip, mine village and borefields

¹ Cautionary Statement: The Mine Plan is a Production Target that contains both a proportion of Indicated and Inferred Mineral Resources (5%). There is a lower level of geological confidence associated with Inferred Mineral Resources and there is no certainty will result in the determination of Indicated and Inferred Mineral Resources convert to Ore Reserves and form part of the final Production Target.

² See Table 9, Rebecca-Roe Gold Project Pre-Feasibility Study – Executive Summary, December 2024



Managing Director, Mark Zeptner said:

“The Rebecca-Roe DFS confirms the excellent economics of the project at a gold price significantly below the current spot price. With production to commence in late 2028, Rebecca-Roe forms an integral part of our 5-Year Growth Pathway released separately today, which lays out the path to production of more than 500,000 ounces a year, cementing our position as one of Australia’s largest and most profitable goldminers.

Along with Dalgara and the Eridanus cutback at Mt Magnet, Rebecca-Roe is a key growth project for Ramelius going forward. Once operational, it will provide us with a new mining hub in an under-explored mining region, which we plan to take advantage of with our proven hub-and-spoke model.”

REBECCA-ROE GOLD PROJECT – DEFINITIVE FEASIBILITY STUDY RESULTS

Summary

A Definitive Feasibility Study (DFS) has been undertaken on the Rebecca-Roe Gold Project, 150km east of Kalgoorlie in the West Australian goldfields. The project demonstrates robust financial returns in a new district that should lend itself well to Ramelius’ proven hub-and-spoke model.

Drilling targeting the underground resource at Roe was recently completed, with a subsequent maiden underground Ore Reserve declared at Roe.

The DFS has been compiled utilising internal and external expertise and the study results are shown in Table 1.



Table 1: Rebecca-Roe Definitive Feasibility Study Summary

Rebecca-Roe	Unit	Definitive Feasibility Study (October 2025)	
General		Total	per unit
Start date (site establishment)	Qtr	December 2027	
Mining commencement	Qtr	December 2027	
Production commencement	Qtr	December 2028	
Initial life	Yrs	9	
Open pit mining			
Tonnes	Mt	20.8	
Grade	g/t	1.31	
Contained gold	Koz	877	
Operating cost (including admin)	A\$M A\$/t	1,342	\$64
Underground mining			
Tonnes	Mt	5.4	
Grade	g/t	1.78	
Contained gold	Koz	311	
Operating cost (including admin)	A\$M A\$/t	680	\$126
Processing			
Tonnes	Mt	26.3	
Grade	g/t	1.41	
Contained gold	Koz	1,187	
Recovery	%	91.5%	
Gold production	Koz	1,086	
Haulage cost	A\$M A\$/t	116	\$4
Processing cost (including admin)	A\$M A\$/t	744	\$28
Royalties	A\$M A\$/oz	206	\$190
Financial			
Growth capital - plant & equipment	A\$M	340	
Growth capital - mine development	A\$M	279	
AISC (excluding corporate costs)	A\$M A\$/oz	2,852	\$2,625
AIC (excluding corporate costs)	A\$M A\$/oz	3,471	\$3,195
Cash flow (pre-tax) @ A\$4,500 (base)	A\$M	1,418	\$1,305
Cash flow (post-tax) @ A\$4,500 (base)	A\$M	1,037	\$955
Cash tax rate	%	27%	
Pre-tax NPV _{5%} @ A\$4,500 (base)	A\$M	970	
Post-tax NPV _{5%} @ A\$4,500 (base)	A\$M	692	



Sensitivity analysis

The forecast free cash flow and net present value (post capex, pre-tax and post-tax) changes with the gold price is detailed Table 2.

Table 2: Forecast free cash flow

Sensitivity Analysis				
Gold Price LOM	Free Cash Flow (pre-tax) A\$M	Free Cash Flow (post-tax) A\$M	NPV (pre-tax) ^{5%} A\$M	NPV (post-tax) ^{5%} A\$M
A\$4,500/oz (base case)	1,418	1,037	970	692
A\$5,250/oz	2,199	1,583	1,563	1,107
A\$6,000/oz	2,979	2,130	2,157	1,523

Key changes from the Rebecca-Roe DFS to the PFS are as follows:

- Maiden Bombora (Roe) underground Ore Reserve 4.4Mt @ 1.8g/t for 260koz
- Mined ore increased by 1.2Mt for an additional 43koz of contained gold
- Focus on consolidating non-processing infrastructure:
 - Single large village to accommodate workforce
 - Sealed aerodrome resized to accommodate larger aircraft
- Capital Costs:
 - Higher village costs – larger camp required to support a long-life asset. Additional rooms compared to the PFS to account for shutdown crews, exploration and project personal. Designed for 460 rooms with a focus on the wellbeing of the workforce
 - Minor increase in processing plant costs to increase throughput from 3.0Mtpa to 3.25Mtpa
 - Construction of the processing plant has been rescheduled from the planned September 2026 Quarter to the December 2027 Quarter to prioritise construction of the Mt Magnet plant upgrade. The commencement of mining at Rebecca also coincides with the revised schedule for the processing plant.
- Operating Costs:
 - Increase in mining costs – more material and ore mined combined with an increase in mining contractor rates
 - Increase in potable water costs, continuing to search for local sources

Key Milestones

- Rebecca Environmental Protection Act Part V - received August 2025
- DFS completed in October 2025, FID approved, subject to Roe environmental permitting
- Bombora Underground Ore Reserves - published October 2025
- Rebecca mining commencement - December 2027 Quarter (Q2 FY28)
- Processing plant construction - December 2027 Quarter (Q2 FY28)
- Production commencement - December 2028 Quarter (Q2 FY29)
- Roe Environmental Protection Act Part IV expected in December 2027 (Q2 FY28) (if assessed)
- Roe mining commencement - June 2028 Quarter (Q4 FY28)



Rebecca-Roe Production Profile

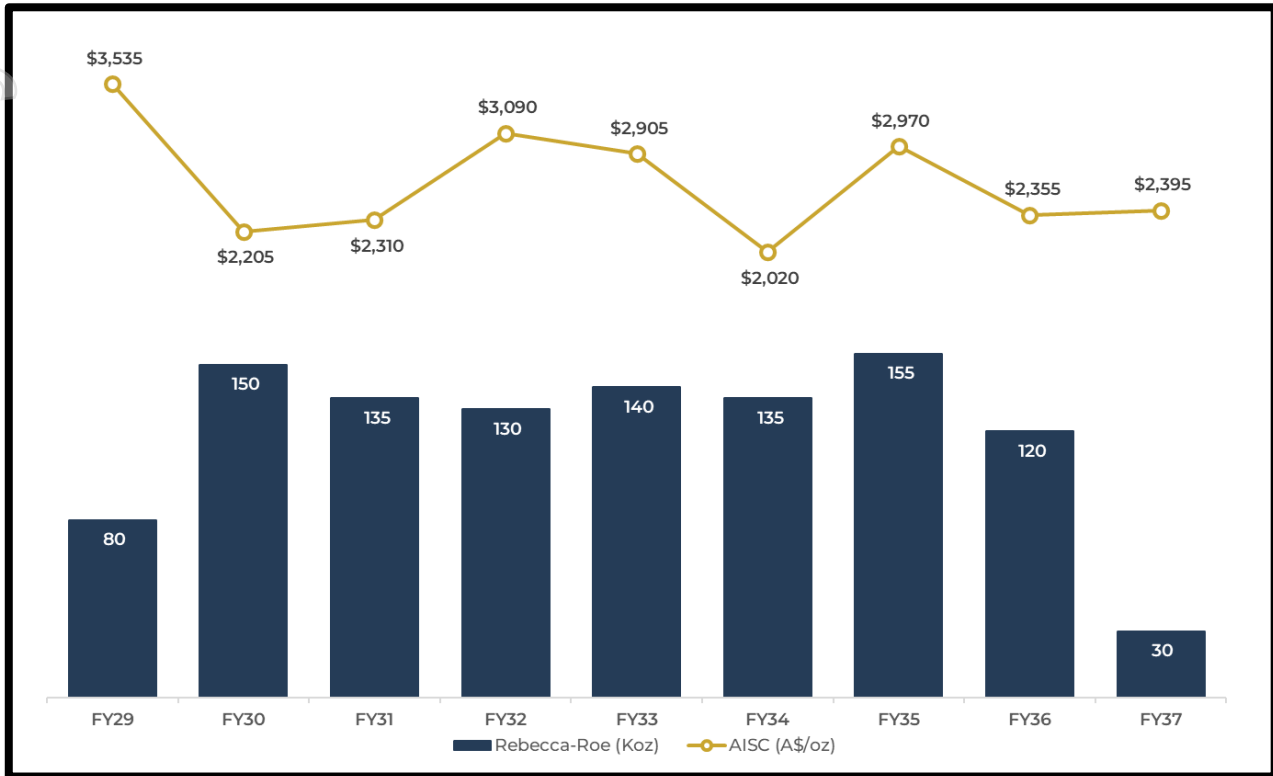

Figure 1: Rebecca-Roe DFS gold production & AISC

This ASX announcement was authorised for release by the Board of Directors.

For further information contact:

Investor enquiries:		Media enquiries:
<p>Mark Zeptner Managing Director Ramelius Resources Ltd Ph: +61 8 9202 1127</p>	<p>Darren Millman Chief Financial Officer Ramelius Resources Ltd Ph: +61 8 9202 1127</p>	<p>Luke Forrestal Director GRA Partners Ph: +61 411 479 144</p>



About Ramelius

For personal use only



Figure 2: Ramelius' Operations & Development Project Locations

Ramelius owns and operates the Mt Magnet, Penny and Cue gold mines, all of which are located in close proximity to the town of Mount Magnet in Western Australia (refer Figure 2). The Dalgarranga and Yalgoo projects became part of the Ramelius portfolio when the Spartan Scheme completed on 31 July 2025. In addition to this Ramelius owns the Edna May, Tampia and Symes gold mines which were placed into care & maintenance in the March 2025 Quarter.

Ore from the high-grade Penny underground and Cue open pits is hauled to the Mt Magnet processing plant, where it is blended with ore from both underground and open pit sources at Mt Magnet.

Rebecca and Roe have been combined into a single project, Rebecca-Roe, with a Pre-Feasibility Study completed in December 2024 and the Definitive Feasibility Study published on 28 October 2025.



REBECCA-ROE GOLD PROJECT DEFINITIVE FEASIBILITY STUDY – SUMMARY

1. INTRODUCTION

This study presents the design and financial evaluation outcomes of the Ramelius Rebecca–Roe Gold Project (RRGP) Definitive Feasibility Study (DFS).

The Project is in a Tier 1 location approximately 150km from Kalgoorlie, in Australia’s premier gold province at the southern end of the Keith – Kilkenny and Laverton Tectonic Zones.

Rebecca has a Mineral Resource of 33Mt @ 1.3g/t Au for 1.4Moz consisting of the Rebecca, Duke, Duchess and Cleo deposits with a Reserve of 18Mt @ 1.2g/t Au for 0.7Moz at Rebecca, Cleo, Duke and Duchess.

In addition, Roe has a Mineral Resource of 34Mt @ 1.6g/t Au for 1.8Moz consisting of the Bombora open pit, Bombora underground and Kopai-Crescent deposits and a Reserve of 7.3Mt @ 1.7g/t for 0.41Moz at the Bombora open pits and underground.

The RRGp, combined Rebecca and Roe deposits, has a total Mineral Resource of 67Mt @ 1.5g/t for 3.2Moz with a Reserve of 25Mt @ 1.4g/t for 1.1Moz.

The key areas of focus during this DFS stage are detailed in Table 3.

Table 3: Key Study activities as part of DFS

Study Area	Definitive Feasibility Study + / - 10% accuracy 10% design / engineering
Drilling	Sterilise drilling for camp, airstrip and Roe waste dump and infrastructure locations
Resources	Upgrade Inferred mineral resources where it makes economic sense
Geotech	Enhance Geotech data for Bombora pits Stress test and modelling to be undertaken on Bombora underground
Hydrogeology	Test program to model Roe UG water inflow Additional bores in Rebecca bore field to be evaluated as alternate water sources Drill bores at Roe to define dewatering requirements of Bombora underground
Mine planning	Refine mine plan and underground reserves Evaluate Cleo, Kopai and Duchess East for potential additional ore sources Issue tender requests for mining contractors
Metallurgy	Additional leach test work with composite of Rebecca-Roe ores
Process plant	Detailed plant design and tender
TSF	Definitive Tailings Storage Facility (TSF) design
Other infrastructure	Detailed non-process infrastructure design and tender
Approvals	Submit approvals applications



2. HISTORY

Rebecca

In the period 1995–97, Aberfoyle Resources Limited (Aberfoyle) entered into a joint venture agreement with Central Kalgoorlie Gold Mines NL (CKGM). This period of work led to drill-definition of the Duchess and Duke mineralised zones.

In 2001, Newcrest Operations Limited entered into an agreement with CKGM and further defined Duke and Duchess.

Apollo Consolidated Ltd (Apollo) acquired the Rebecca Project in 2009 and through deeper drilling, discovered the Rebecca deposit in 2012 that returned several high-grade intercepts with a best result of 42m @ 7.75g/t Au. In early 2020, Apollo released a 2012 JORC-compliant Maiden Mineral Resource for the Rebecca Project of 21.7Mt at 1.2g/t Au for 1.035Moz of gold.

In December 2021, Ramelius acquired Apollo. Ongoing work over the Rebecca Project has included extensive resource definition drilling, geotechnical diamond core drilling and sterilisation drilling over future mine infrastructure locations at Rebecca, Duchess and Duke deposits. Exploration drilling (air core and reverse circulation) across several identified exploration targets within the project tenure were also progressed.

Roe

Historical holders of the Project area include Poseidon Limited, WMC Resources Ltd, Aberfoyle, Mt Kersey Mining NL and Great Gold Mines NL. Vertical RAB and aircore drilling undertaken in the period 1991 to 1998 identified a zone of strong gold anomalism over a potential distance of 4km under thin (5-10m) cover.

Recent exploration of the Roe Project was initiated in November 2014 when Breaker Resources NL (Breaker) applied for tenement E28/2515. The tenement was granted in May 2015 and field exploration activities started in July 2015 with the maiden air core program. The primary discovery of Bombora was made during the maiden RC drilling program which started in February 2016 with multiple holes intersecting visible gold.

In April 2018, Breaker Resources published a 2012 JORC-compliant Maiden Mineral Resource for Bombora of 11.8Mt at 1.6g/t Au for a contained 624koz. Resource delineation drilling by Breaker continued with Mineral Resource updates for Bombora released in September 2018 and September 2019.

In April 2021, Breaker Resources released a new Mineral Resource Estimation for the Roe Project comprising Bombora and two new resources at Kopai-Crescent and Claypan for a combined total resource of 27.9Mt at 1.5g/t Au for 1.370Moz of gold. This was superseded in December 2021 with another Roe Project Mineral Resource update of 31.9Mt at 1.6g/t Au for 1.684Moz of gold.

In May 2023, Ramelius acquired Breaker. Under Ramelius, resource drilling to convert inferred ounces into the indicated resource category is ongoing as well as exploration of several regional targets and prospects around the existing gold resource.

3. LOCATION & TENURE

The Rebecca Gold Project is located 150km north-east of Kalgoorlie, accessible via the Yarri and Kurnalpi-Pinjin Roads and then by station tracks, see Figure 3.



The Roe Gold Project is situated approximately 105km east of Kalgoorlie by road. Access from Kalgoorlie is via the Trans Access or Kurnalpi-Pinjin Roads which are linked via a north-south pastoral station track immediately to the west of the project area. Access into the Project is by pastoral track, south of the Yindi Pastoral Lease. The Bombora deposit is located 50km directly south-west of the Rebecca deposits, and 70km via existing tracks.

Both project areas lie within the Shire of Kalgoorlie-Boulder and predominantly on the Yindi Pastoral Lease (Cowarna Downs Station).

The Rebecca Mineral Resources are situated on M28/400 and the Roe Mineral Resources are situated on M28/388. Both granted tenements are held by fully owned subsidiaries of Ramelius. M28/401 (pending) is required to accommodate an abandonment bund and surface water management infrastructure around the main Rebecca open pit. Miscellaneous Licences (yet to be applied for) will be required for access and haulage roads between the sites.

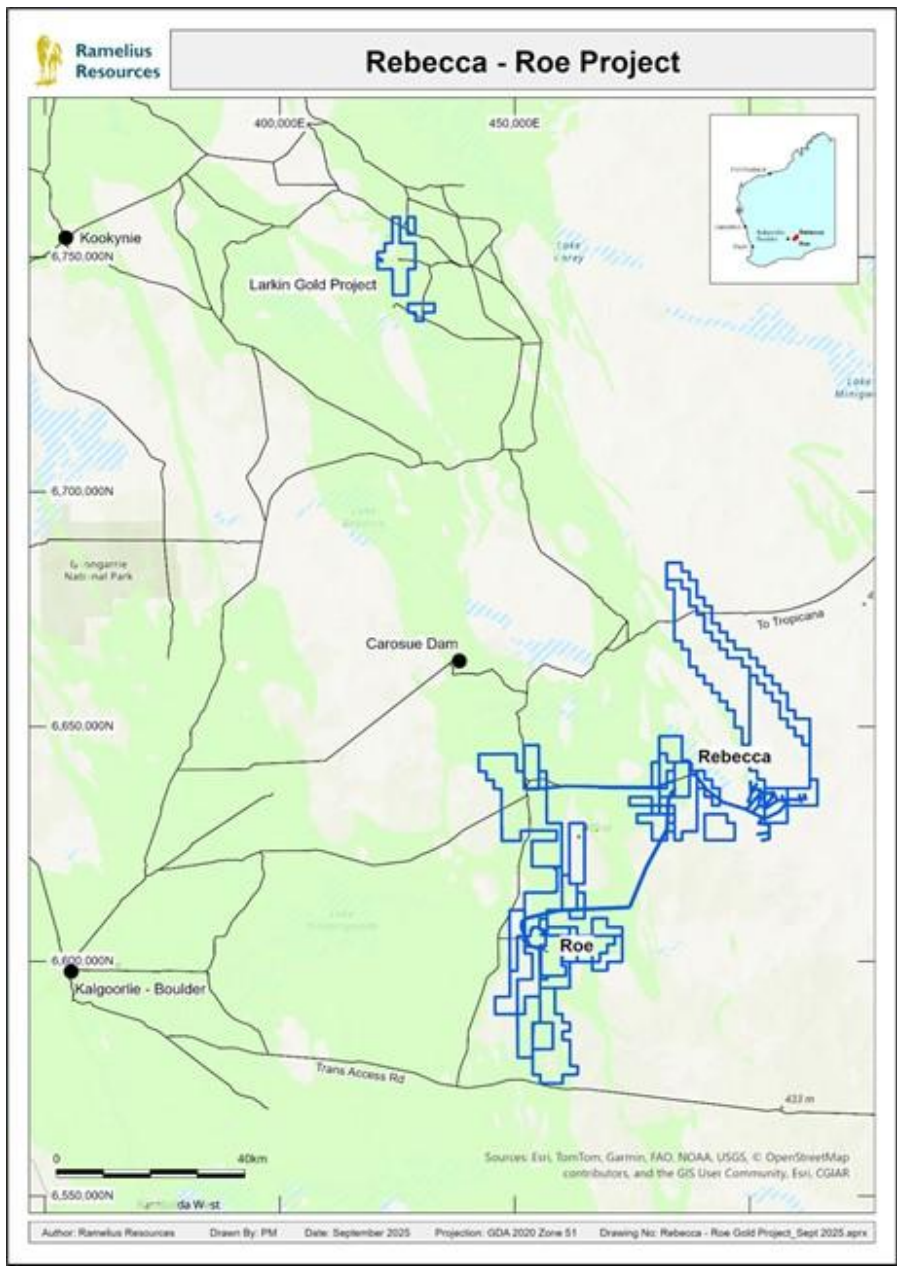

Figure 3: Rebecca-Roe Gold Project (RRGP) location



4. PROJECT SCHEDULE

Table 4 depicts the Project Schedule for Rebecca and Roe deposits.

Mining is planned to commence at the Rebecca deposit in December 2027 Quarter upon the granting of outstanding tenure and subsequent approval of the MDCP. The Rebecca processing plant and TSF construction will also commence in the December 2027 Quarter with commissioning of the plant in December 2028 Quarter.

Ramelius has decided to refer mining of Roe to the EPA under Part IV. A two (2) year timeframe has been allowed for an assessment. If the EPA decides not to assess Roe as Part IV; Ramelius will proceed with the submission of Roe under Part V.

Mining at Roe is scheduled to commence in June 2028 Quarter, but this may be brought forward if the project is to be assessed under Part V.

Table 4: RRGP Project Schedule

	Financial Year Quarter	FY26				FY27				FY28				FY29			
		Q1	Q2	Q3	Q4	Q1	Q2	Q3	Q4	Q1	Q2	Q3	Q4	Q1	Q2	Q3	Q4
Mt Magnet Dalgarranga	Amendment to Approval	[Yellow bar]															
	Mt Magnet Plant					[Grey bar: Expansion Works]				[Yellow bar]							
	Mining	[Blue bar]															
Rebecca	Final Approvals	[Yellow bar]				[Yellow bar]											
	Infrastructure					[Yellow bar]				[Yellow bar]							
	Process Plant - Construct									[Grey bar]				[Yellow bar]			
	Mining Commences									[Blue bar]				[Blue bar]			
Roe	Approvals - Part IV	[Yellow bar: Part IV]				[Yellow bar]				[Yellow bar]							
	Approvals - Part V	[Grey bar]				[Yellow bar]				[Yellow bar]							
	Infrastructure									[Yellow bar]							
	Mining Commences									[Blue bar]				[Blue bar]			

5. GEOLOGY

Rebecca

Gold mineralisation along the Rebecca structural corridor (refer Figure 4) extends over at least 1.8km strike and encompasses three major sub-parallel, moderate west dipping and north-south trending structures (Jennifer, Laura and Maddy). The lodes consist of disseminated sulphide/gold mineralisation within strongly foliated and locally silica altered and sheared gneiss up to 30m wide (true width), as well as multiple adjoining narrower stacked lodes of lower-grade mineralisation.

The geology at Rebecca features a folded sequence of gneiss, amphibolite and diorite. A 10m wide sub-vertical, NE-SW striking ultramafic dyke unit occurs in the northern half of Rebecca, cutting across the mineralisation.

The Duchess deposit occupies a broad area approximately 1.2km long and up to 900m wide, located approximately 4.5km south-west of Rebecca. The area is characterised by widespread sub-horizontal layers of mineralised material in the lower oxide profile, and multiple north trending and moderate west-dipping disseminated sulphide structures in underlying fresh granodiorite and micro-diorite gneiss.

The Duke deposit lies 1km to the south of Duchess in a north-west striking zone along the western limb of a project-wide fold. Mineralisation is steeply dipping and hosted in a single lode



zone (10-25m wide), associated with moderate disseminated sulphides in weakly silicified felsic gneiss.

The Cleo deposit is located approximately 1.5km to the west of Rebecca. The local geology consists of a strongly folded sequence of diorites, amphibolites and metasediments that are cross-cut by steeply dipping (60-70°), narrow barren pegmatite veins. The main zone of mineralisation occurs as a broad (up to 30m wide), north trending, steeply west dipping (50-70°) lode within the diorite. There are a series of thinner (2-5m wide) north trending hanging wall and footwall lodes with westerly dips ranging from shallow to steep (25-65°).

The Duchess and Duke mineralised areas have local sub-cropping oxidised bedrock overlain by sandy and calcareous soils, while the 1.7km Rebecca mineralised corridor lies in an area of transported cover that is part of a local NE trending palaeo-drainage that trends diagonally from Duchess and into Lake Rebecca. Rebecca has up to 30m of transported cover on oxidised leached bedrock (saprolite), for a total 35-50m of unmineralised and/or depleted overlying material. The transported and oxide profile is generally unlithified below local hardpan caprock.

The Rebecca Project drill hole database is comprised of a combination of historic holes drilled by previous owners and recent RC and diamond drilling conducted by Ramelius. Drillholes at Rebecca are orientated orthogonal to the geological and mineralised trend. Intercept angles are often near perpendicular. Typically, as -60° east dipping holes drilling 40-50° west dipping lodes.

Selected metallurgical holes drill down the lodes. RC drill spacing varies depending on stage of the prospect – infill and step out (extensional) programmes were drilled on nominal 20m to 40m centres.

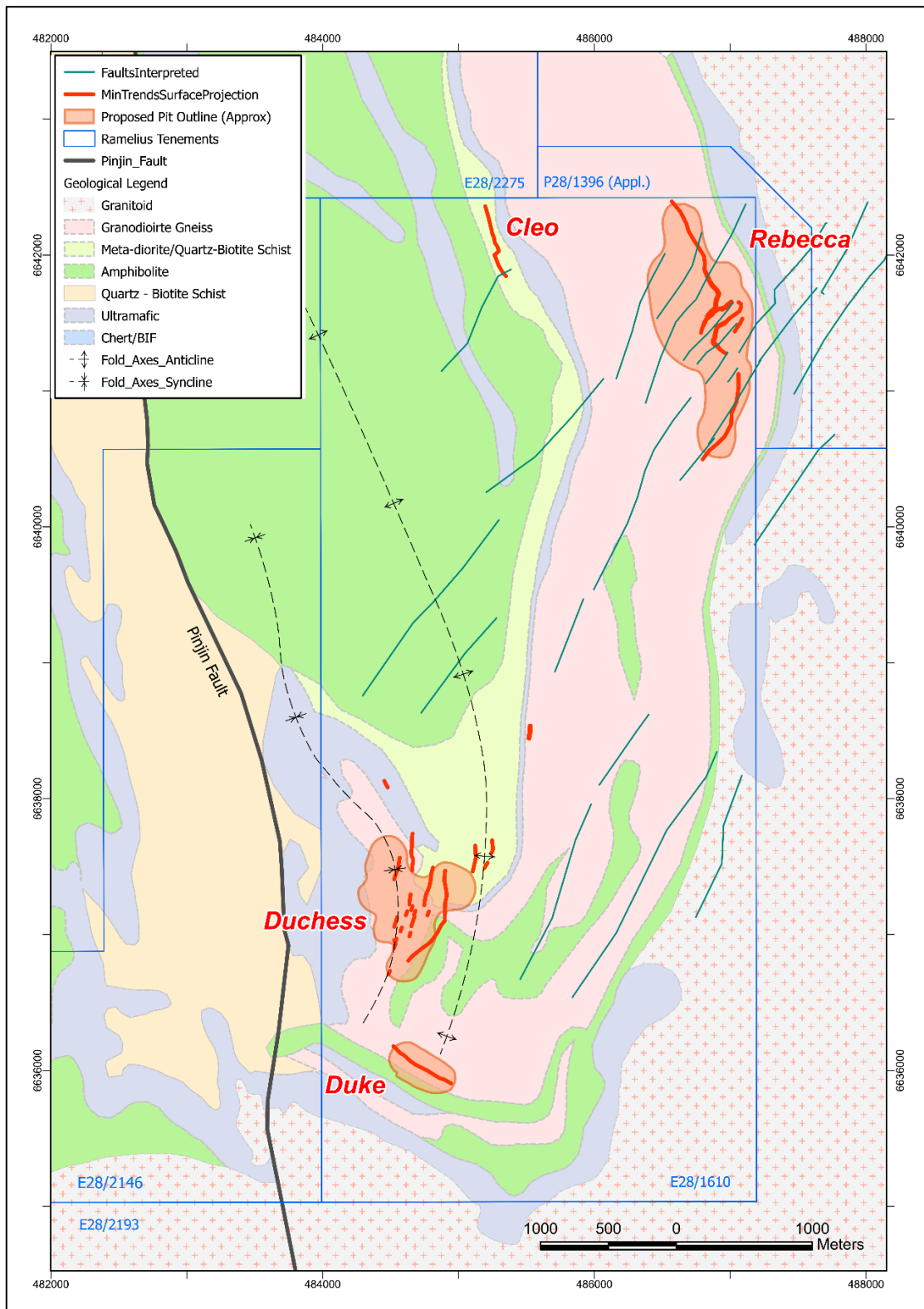

Figure 4: Rebecca Project Geology Plan View

The greenstone geology of the Roe project area (Figure 5) can be divided into the Yindi (Western) domain and the Edjudina (Eastern) domain. The Yindi Domain is centred around the ~60-70° E-dipping Roe Shear Zone corridor. Lithology is dominated by mafic amphibolite, fine-to coarse-grained felsic-intermediate schists and turbiditic siltstone-shale.



The Edjudina domain is distinguished from the Yindi domain by major lithological, metamorphic and structural changes that occur across the interpreted western branch of the Claypan Shear Zone. A major lithological distinction is the presence of large volumes of high-Fe tholeiitic mafic rocks, mostly in the form of fractionated dolerite sills. The Bombora Sill is the largest of these bodies and hosts most of the gold mineralisation at Bombora. The main body of the Bombora Sill is 150-300m in true thickness at the centre of the project area, but magmatic and/or structural duplication creates a sill complex up to ~500m true thickness towards the southern end of the Resource area.

The Kopai-Crescent deposit is located approximately 2km to the north of Bombora on the northern extension of the eastern branch of the Claypan Shear Zone. The host rocks consist of an east-dipping package of mafic to intermediate volcanics, local metasediments and black shales, intruded by numerous, small bodies of dolerite (both fractionated and massive) and localised lamprophyres. The area is overlain by transported lake sediments which are typically 5-10m thick. The weathering profile is generally shallow, with a stripped upper saprolite and a top of fresh rock surface located at ~35m depth.

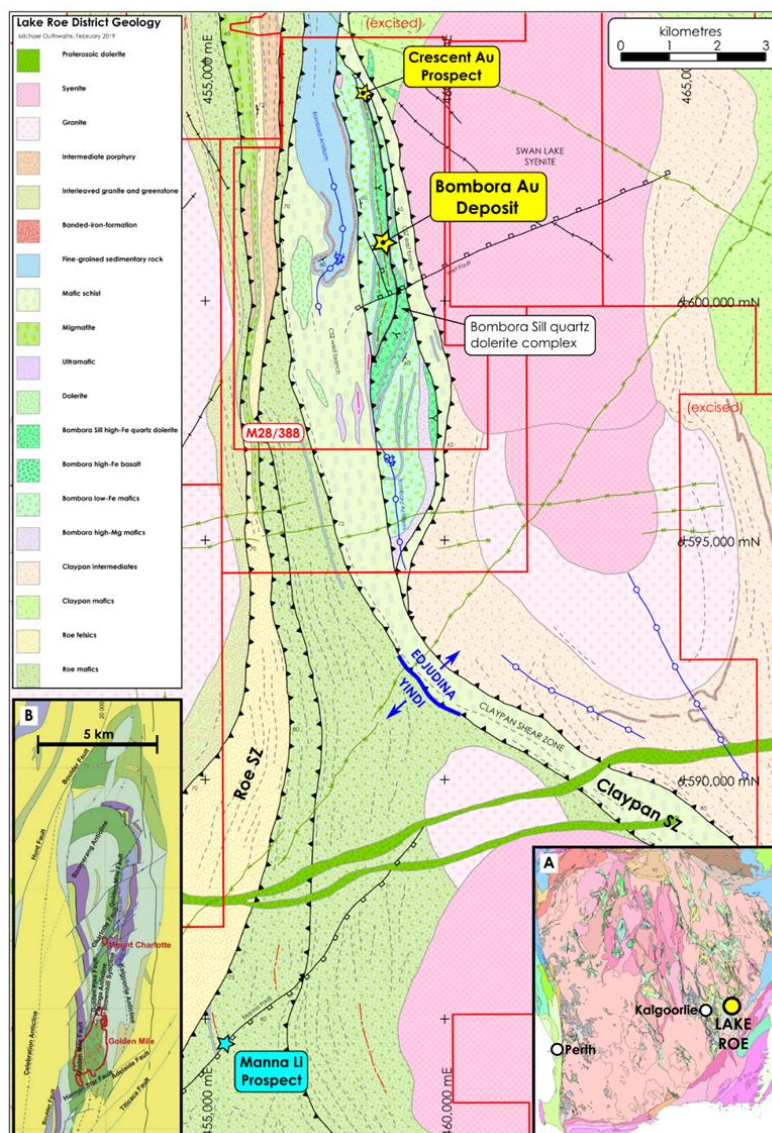

Figure 5: District geology of the Lake Roe project with significant structures (black), GSWA domain boundaries (blue)



Gold mineralisation at Bombora is largely stratabound, occurring preferentially in the ~150m thick, iron-rich granophyric quartz dolerite zone of the Bombora Sill over a 3km strike length. Mineralisation is hosted in three main lode orientations: (1) north-northwest-striking, sub-vertical steep lodes; (2) gently north- to northeast-dipping flat lodes and (3) moderately west-dipping west lodes. The mineralisation is controlled in two ways:

- Lithological control: where structures intersect the competent, magnetite-rich quartz dolerite. Mineralisation occurs via the sulphidation process, with the dominant alteration assemblage identified as silica-albite-pyrrhotite. These shoots have a southern shoot plunge.
- Structural control: at the intersection of multiple structures. When the intersection involves a west-dipping structure the primary alteration assemblage of silica-albite-pyrrhotite is overprinted by carbonate-biotite-pyrite. This control gives a gentle north plunging orientation to the shoots, equivalent to the orientation of sigma two in the stress ellipsoid. This control is mainly observed in the quartz dolerite, where the structures are better developed, but is also observed outside of the quartz dolerite.

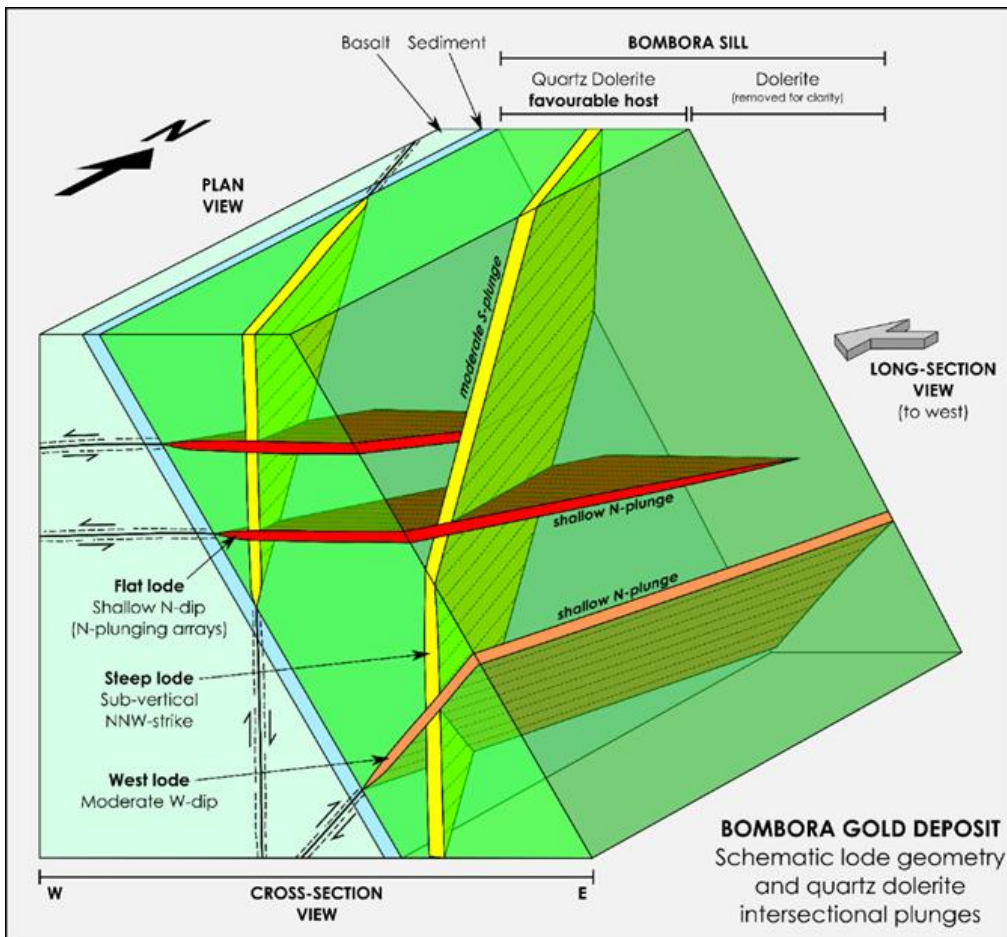

Figure 6: Structural model of the Bombora deposit

The Bombora deposit is totally concealed under a thin (5 to 15m) layer of transported cover developed within and peripheral to the Lake Roe Salt Lake system. The transported cover is dominated by lacustrine clays, overlain by aeolian sands and transported ferricrete adjacent to the lake footprint. The in-situ regolith profile is strongly stripped, with the upper saprolite rarely preserved in the deposit area.



The Roe database is comprised of a combination of historic RC and diamond drilling combined with recent drilling conducted by Ramelius. At Bombora, drill holes are on a nominal spacing of 40m x 20m with areas at a 20m x 20m spacing completed every 200 metres along strike in the shallow part of the Bombora resource to ~200-250 meters below surface). At Claypan, the drill spacing is on a nominal 200m x 80m reconnaissance pattern. At Kopai-Crescent, the drill spacing is on a nominal 100m x 40m with local infill to 40m x 20m in the southern (Crescent) area and within the Indicated Resource areas.

6. MINERAL RESOURCE ESTIMATES

Rebecca

The Rebecca Project Mineral Resource Estimate (MRE) was generated in June 2023 by Ramelius and has been classified and reported in accordance with the JORC Code (2012). The model is an Ordinary Kriging estimate using a conventional constrained lode method, with topcuts and variograms. It comprises a total Resource of 33.0Mt grading 1.3g/t for 1.4Moz of contained gold as detailed in Table 5. The Rebecca Gold Project MRE is inclusive of Mineral Reserves.

Table 5: Rebecca Project Mineral Resource Estimate

Deposit	Indicated			Inferred			Total		
	Tonnes (Mt)	Grade (g/t)	Ounces (koz)	Tonnes (Mt)	Grade (g/t)	Ounces (koz)	Tonnes (Mt)	Grade (g/t)	Ounces (koz)
Rebecca	17.0	1.5	820	3.1	1.4	140	20.0	1.5	960
Duchess	7.3	0.9	220	2.4	0.9	72	9.7	0.9	290
Duke	2.0	1.1	73	0.7	1.1	25	2.7	1.1	98
Cleo	0.7	1.1	26	0.2	1.0	8	0.9	1.1	34
Total	27.0	1.3	1,100	6.5	1.2	240	33.0	1.3	1,400

Figures rounded to 2 significant figures. Rounding errors may occur.

6.1 Estimation

Estimation was generated by domain using anisotropic search ellipses. Both Inverse Distance and Ordinary Kriging estimates were generated for each domain using topcut and uncut composited Au grades for comparison. Search ellipses were interpreted based on lode orientations and grade continuity. Generally, the strike grade continuity appears more significant than down-dip continuity and searches are modestly weighted toward strike directions.

Semi-variograms were generated and used to determine Ordinary Kriging parameters. A Normal Scores transform was used with the sill set to a maximum value of 1.0. The same search ellipses were used for both Inverse Distance and Ordinary kriging estimates.

At Rebecca, the smaller domains were grouped together based on orientation and position, with one variogram produced for each group (North, Central and South). Estimates were run on individual domains, with only samples from the domain in question being used to estimate blocks. This was also done at Cleo with domains grouped into either Main Lode, Hanging Wall or Footwall.

A hole count process was also utilised with a minimum number of holes (2-4) required with a minimum of one sample per hole and maximum of eight samples. Two search passes were used



for most domains. Compositing was applied at 1m intervals. Geostatistical populations were reviewed and top cuts were applied per mineralisation domain ranging from 10 - 18g/t.

Roe

The Roe Project MRE was generated in August 2024 by Ramelius and has been classified and reported in accordance with the JORC Code (2012). The model is an Ordinary Kriging estimate using a conventional constrained lode method, with top cuts and variograms. It comprises a total Resource of 34.0Mt grading 1.6g/t for 1.8Moz of contained gold as detailed in Table 6. The Roe Gold Project Mineral Resource is inclusive of Mineral Reserves.

Table 6: Roe Project Mineral Resource Estimate (2408 Model)

Deposit	Indicated			Inferred			Total		
	Tonnes (Mt)	Grade (g/t)	Ounces (koz)	Tonnes (Mt)	Grade (g/t)	Ounces (koz)	Tonnes (Mt)	Grade (g/t)	Ounces (koz)
Bombora Open Pit	16.0	1.5	740	3.1	1.3	130	19.0	1.4	870
Bombora Underground	4.3	2.5	350	4.7	2.1	320	9.0	2.3	670
Kopai-Crescent	2.9	1.2	110	1.5	0.9	45	4.4	1.1	150
Claypan				2.0	1.1	69	2.0	1.1	69
Total Roe Project	23.0	1.6	1,200	11.0	1.6	560	34.0	1.6	1,800

Figures rounded to 2 significant figures. Rounding errors may occur.

Bombora open pit reported above 0.5g/t cutoff and above the 100mRL.

Bombora underground reported above 1.0g/t cutoff and below the 100mRL.

Kopai Crescent and Claypan reported above 0.5g/t cutoff.

6.2 Estimation

Estimation was generated for Bombora and Kopai-Crescent using anisotropic search ellipses. Both Inverse Distance and Ordinary Kriging estimates were generated for each lode using top cut composited Au grades for comparison. Interpreted search ellipses were interpreted based on lode orientations and grade continuity. Ordinary Kriging was selected as the final estimate for resource reporting. Semi-variograms were generated in Supervisor V8 software product and used to generate Ordinary Kriging parameters.

Timing relationships observed in core at Bombora demonstrate that the steep lodes are the earliest mineralised structures, crosscut by the flat laminated veins and the west-dipping lodes. This timing relationship has been replicated in the block model using the overprinting precedence of the mineralised domains.

Compositing was applied at 1m intervals. Geostatistical populations were reviewed, and top cuts were applied per mineralisation domain ranging from 3 - 20g/t.

7. ENVIRONMENTAL

Ramelius held scoping meetings with key regulators (Department of Mines, Petroleum and Exploration (DMPE), Department of Water and Environmental Regulation (DWER) and Environmental Protection Authority (EPA) to present the project scope, discuss risks, and outline approvals timeframes. Separate environmental approval applications will be lodged for each of the Rebecca and Roe projects.



Approval to commence construction of the processing plant, TSF, power plant, landfill, installation of a waste-water treatment plant and mine dewatering infrastructure at Rebecca was granted in August 2025.

A groundwater abstraction licence application for up to 0.9GI/yr to dewater the Rebecca, Duke and Duchess open pits was granted in March 2025.

A further licence to abstract approximately 3GI/yr from the Rebecca paleochannel borefield is required and Ramelius intends to submit an application for a groundwater licence towards the end of 2025.

A Mining Development and Closure Proposal in accordance with the Mining Act will be submitted when outstanding project tenure is granted.

Ramelius intends to refer the Roe project to the EPA in accordance with Part IV of the EP Act on the basis of possible impact to inland waters. If, on the basis of information included in the referral document, the EPA decides not to assess the project under Part IV of the EP Act, project approvals will be managed in accordance with Part V.

If the EPA decides to assess the project under Part IV of the EP Act, there is no defined assessment timeframe and therefore the schedule is an estimate only.

A groundwater abstraction licence application is required and will be informed by the completed groundwater exploration drilling study. Results from this study confirm that dewatering yields can be managed by site infrastructure. Ramelius submitted an application for a groundwater licence for the Roe Project in September 2025.

Table 7 and 8 details the types of licences/permits required to commence construction of the Rebecca-Roe project and their current status.

Table 7: Rebecca Licences and Permit Status

Rebecca	Jun 25	Sep 25	Dec 25	Mar 26	Jun 26	Sep 26	Dec 26	Mar 27	Jun 27	Sep 27	Dec 27	Mar 28	Jun 28
Environmental Protection Act - Part V													
Mining Act – Mining Development & Closure Proposal ¹													
RIWI Act - Licence to take water													

¹Submission date dependent on granting of tenure
NB: the end date is the expected date of approval

Table 8: Roe Licences and Permit Status

Roe	Jun 25	Sep 25	Dec 25	Mar 26	Jun 26	Sep 26	Dec 26	Mar 27	Jun 27	Sep 27	Dec 27	Mar 28	Jun 28
Environmental Protection Act Part IV													
Environmental Protection Act - Part V ¹													
Mining Act - Mining Development & Closure Proposal ²													
RIWI Act - Licence to take water													

¹If EPA decides not to assess as Part IV, submission under Part V to progress

²Submission date dependent on granting of tenure
NB: the end date is the expected date of approval



Rebecca - Roe Layout

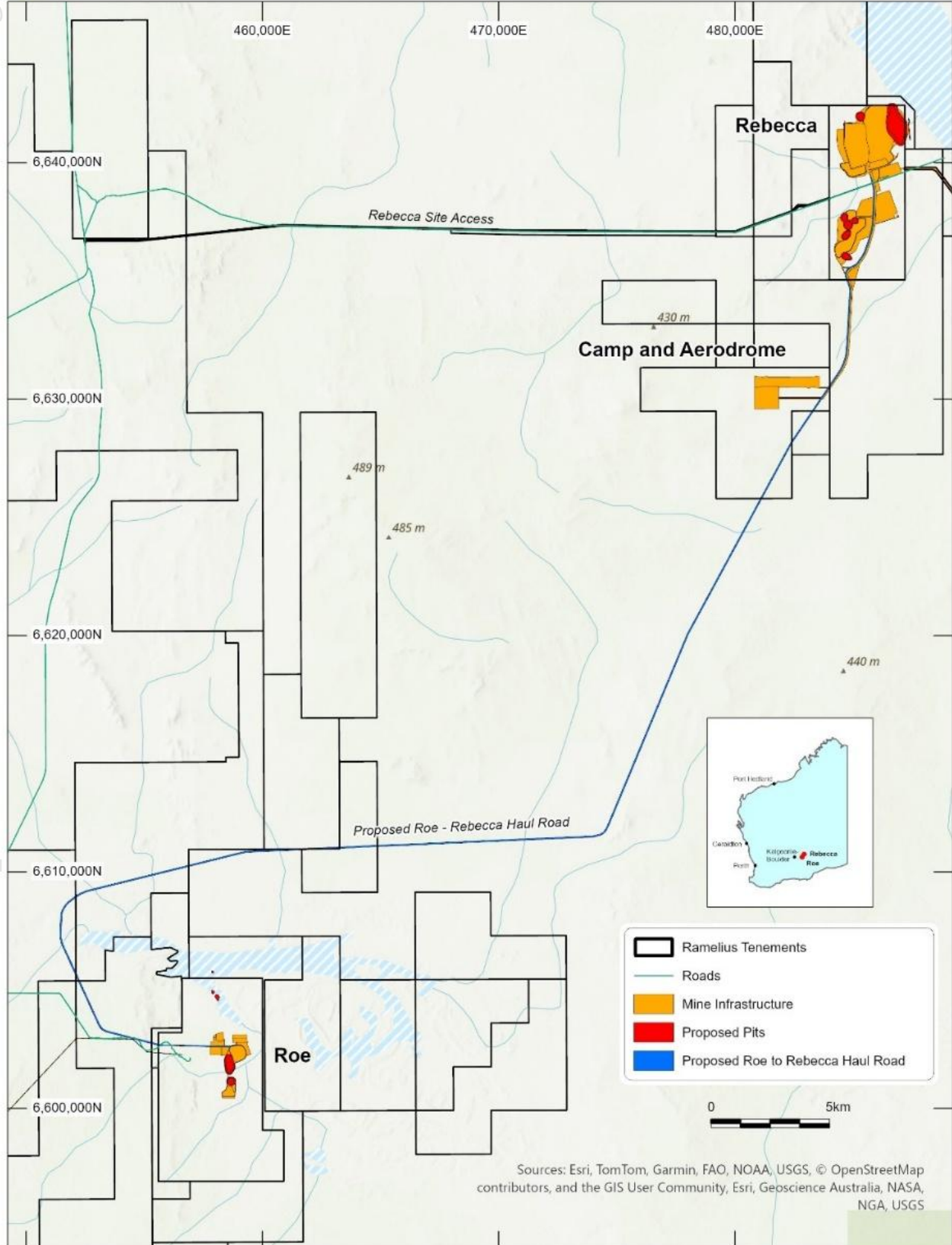

Author: Ramelius Resources Drawn By: PM Date: October 2025 Projection: GDA 2020 Zone 51 Drawing No: Rebecca - Roe Gold Project_Sept 2025.aprx

Figure 7: Rebecca-Roe Gold Project site layout



8. MINING

The mining operations for this project will employ both open pit and underground mining methods. Rebecca will be conducted using an open pit method exclusively whilst Roe will utilise both open pit and underground mining methods. Underground mining at Rebecca remains an opportunity in the future.

8.1 Open Pit Mining

The resource models were regularised to achieve the practical size for open pit mining.

For the Rebecca, Duke and Duchess deposits, Ramelius selected a Selected Mining Units (SMU) size of 5.0mE by 5.0mN by 2.5mRL, which was deemed appropriate for mining with an excavator on a 5.0m bench and 2.5m flitches.

For the Roe open pits, a smaller SMU size of 2.5mE by 2.5mN by 2.5mRL was chosen, as it better suited the mining method proposed.

A 5% mining dilution and 98% mining recovery has been used at Rebecca with Roe dilution set at 10% and mining recovery also set at 98%.

Overall strip ratio for open pit mining is 8.9:1 but varies between 5.7: to 20.1 for the various pits.

The open pit mining will utilise a variety of equipment fleets for material handling:

- A Rebecca initial movement will be using 300-tonne class excavator with 150-tonne payload trucks. Then transitioning to 200-tonne class excavator with 150-tonne payload trucks
- The other pits will be mined with a combination of either 200 or 120-tonne class excavators with 100-tonne payload trucks

8.2 Schedule

The mining sequence for the project will be organised as follows:

- Cleo and Rebecca Stage 1 Pits: Mining at the Cleo pit will commence in the December 2027 Quarter, followed by the start of Rebecca Stage 1 in the March 2028 Quarter. From this point, both pits will be mined concurrently until Cleo operations conclude in the September 2028 Quarter. This overlap presents a strategic opportunity for enhanced water management north of the TSF
- Bombora pits: Mining will commence in the September 2028 Quarter, following the assessment of the Roe project in accordance with the EPA's Part IV application
- Bombora underground mining: Set to commence in the September 2031 Quarter, underground mining will start once all Bombora pits are completed. This ensures that surface mining operations in Bombora do not interfere with underground activities
- Rebecca Stage 2 pit: This will begin once Rebecca Stage 1 reaches a depth of approximately 115 metres below surface (mbs) in the June 2030 Quarter. By initiating Stage 2 at this point, the project can maintain operational momentum, preventing productivity bottlenecks that could occur if all three dig units were confined to the restricted Stage 1 floor
- Duke and Duchess pits: Mining operations at the Duke pit are scheduled to commence in the September 2033 Quarter, with activities at the Duchess pits to follow upon completion of both Rebecca stages in the March 2034 Quarter

8.3 Roe Underground Mining – Bombora Underground

The Bombora underground mine will be accessed from three portals located in the BOM1800 pit. Mining of the BOM1800 pit will be complete prior to portal establishment. The smaller BOM1100 pit will be used for a primary ventilation exhaust raise which is not required until 20 months after underground development commences.

Mining will be undertaken with mobile diesel-powered equipment and electric hydraulic drills. Peak fleet reaches four development jumbos, three production drill rigs, five loaders and seven trucks.

The Bombora underground mine will be mined to a depth of 550m below surface (-244mRL).

The Bombora underground mine plan consists of a number of mining areas with varying mine design features:

- Steep lodes with widths generally around 2m to 9m thickness
- West lodes with widths generally around 2m to 6m thickness
- Flat lodes with heights generally around 5m but varying between 2m and 16m

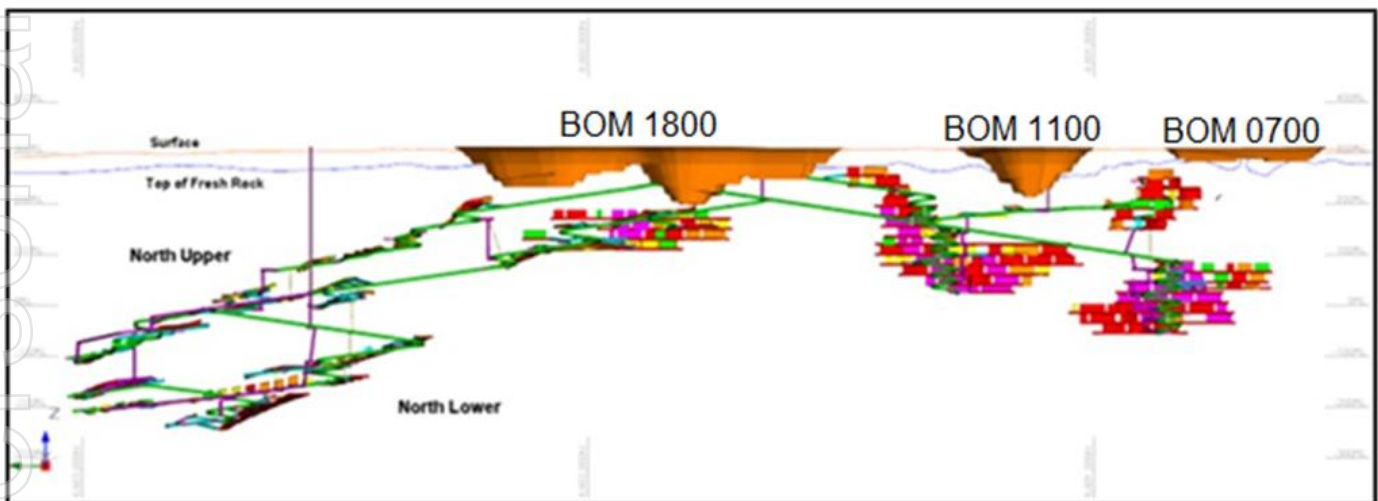

Figure 8: Bombora Underground Long Section (looking east)

Steep and West lodes will be extracted with long hole open stoping, top down with rib and sill pillars for hanging wall support.

Flat lodes will be extracted with long hole open stoping with rib pillars for hanging wall support, for flat lodes targeting a single lode. Ore drives will be driven along the footwall of the lode at 20m spacing down dip. The ore between the ore drives is long hole open stoped from the lower drive and pillars are left as required to limit hanging wall spans.

Bulk stoping will be used where flat lodes are close enough to combined into a single stope. Stope dimensions are 20m wide down dip and up to 80m along strike. Pillars are left between stopes (nominally 8m wide).

For the Bombora underground mining operations, different dilution rates are applied based on stope geometry to manage the quality and quantity of ore extracted. Dilution allowance varies from 5% in bulk stopes to 10% narrower steep and west stopes and up to 67% in flat stopes where additional planned dilution is required to aid recovery of the stope ore. Mining recovery



assumptions include pillar allowances. Stope cut-off grades have been applied based on stope geometries and range from 1.0 to 1.3g/t.

8.4 Production Target

The DFS is based upon mining a Production Target of 1.2Moz based predominately upon Measured and Indicated portions of the Mineral Resource with 57koz drawn from Inferred categories. Table 9 details the Rebecca Roe Production Target by resource category.

Table 9: RRGP - Production Target by Mineral Resource Category

REBECCA-ROE GOLD PROJECT - PRODUCTION TARGET BY RESOURCE CATEGORY										
Project	Mine	Measured & Indicated			Inferred			Total (Indicated + Inferred)		
		Tonnes	Au	Au	Tonnes	Au	Au	Tonnes	Au	Au
		Mt	g/t	Koz	Mt	g/t	Koz	Mt	g/t	Koz
REBECCA	Rebecca	15.0	1.3	630.0	0.0	1.3	0.8	15.0	1.3	630.0
	Cleo	0.4	1.0	13.0	0.0	0.9	0.2	0.4	1.0	14.0
	Duke	0.5	1.0	15.0				0.5	1.0	15.0
	Duchess	2.4	0.9	71.0				2.4	0.9	71.0
ROE	Bombora	2.9	1.6	150.0	0.0	0.9	0.8	2.9	1.6	150.0
	Total Open Pit	21.0	1.3	880.0	0.1	1.0	1.8	21.0	1.3	880.0
ROE	Bombora UG	4.4	1.8	260.0	1.0	1.7	55.0	5.4	1.8	310.0
	Total Underground	4.4	1.8	260.0	1.0	1.7	55.0	5.4	1.8	310.0
Total RRGP Inventory		25.0	1.4	1,100.0	1.1	1.7	57.0	26.0	1.4	1,200.0

Figures rounded to 2 significant figures. Rounding errors may occur

There is a low level of geological confidence associated with Inferred Mineral Resources and there is no certainty that further exploration work will result in the determination of Indicated Mineral Resources or that the Production Target itself will be realised.

8.5 Ore Reserve

An Ore Reserve of 1,100koz has been estimated for the Project as detailed in Table 10.

Table 10: RRGP - Open Pit and Underground Ore Reserve

REBECCA-ROE GOLD PROJECT - ORE RESERVE										
Project	Mine	Proven			Probable			Total Reserve		
		Tonnes	Au	Au	Tonnes	Au	Au	Tonnes	Au	Au
		Mt	g/t	Koz	Mt	g/t	Koz	Mt	g/t	Koz
REBECCA	Rebecca	-	-	-	15.0	1.3	630	15.0	1.3	630
	Cleo	-	-	-	0.4	1.0	13	0.4	1.0	13
	Duke	-	-	-	0.5	0.9	15	0.5	0.9	15
	Duchess	-	-	-	2.4	0.9	71	2.4	0.9	71
ROE	Bombora	-	-	-	2.9	1.6	150	2.9	1.6	150
	Total Open Pit	-	-	-	21.0	1.3	880	21.0	1.3	880
ROE	Bombora Underground	-	-	-	4.4	1.8	260	4.4	1.8	260
	Total Underground	-	-	-	4.4	1.8	260	4.4	1.8	260
Total RRGP Reserve		-	-	-	24.4	1.4	1,100	24.4	1.4	1,100

Figures rounded to 2 significant figures. Rounding errors may occur



Rebecca Site Layout

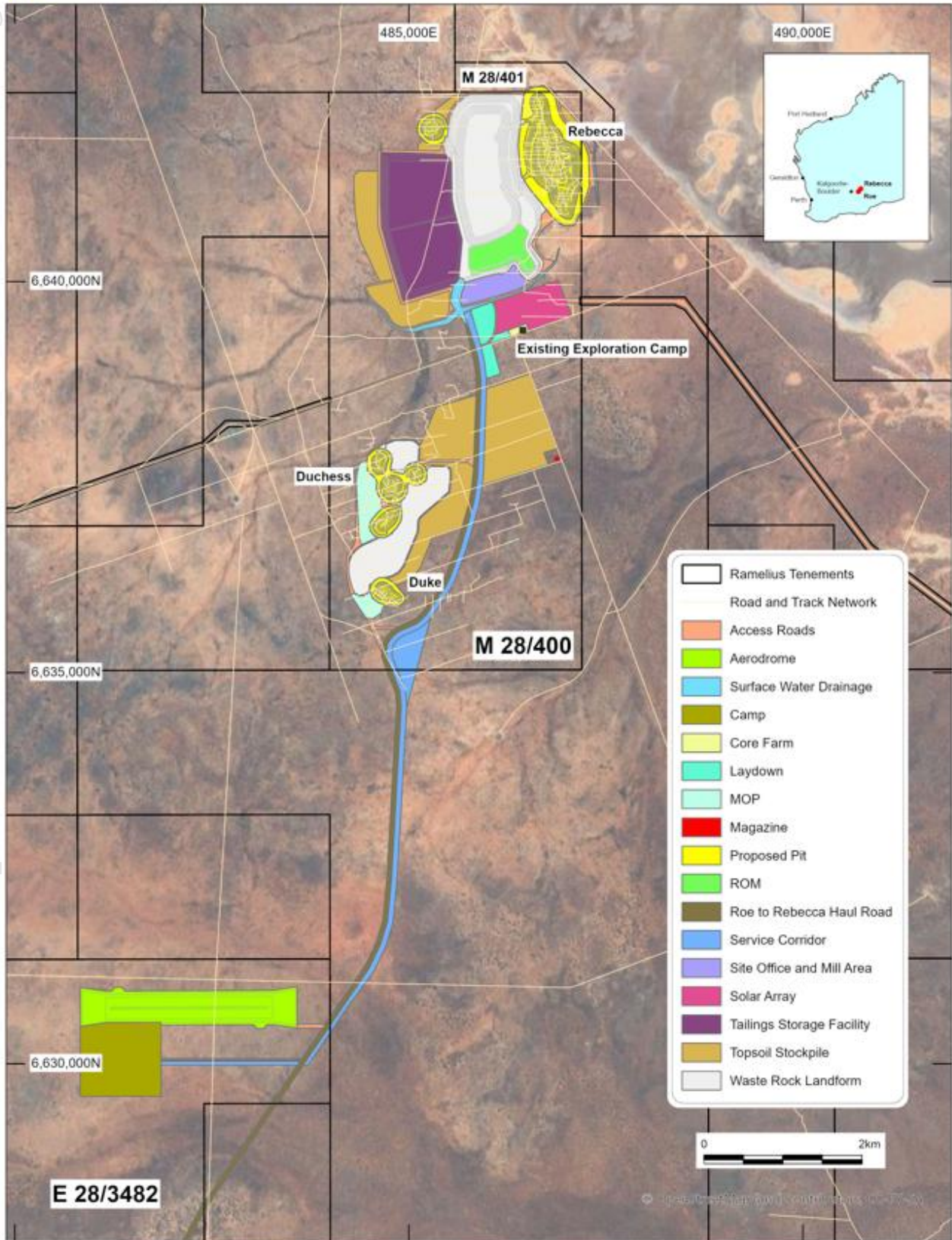

Author: Ramelius Resources Drawn By: PM Date: October 2025 Projection: GDA 2020 Zone 51 Drawing No: Rebecca - Roe Gold Project_Sept 2025.aprx

Figure 9: Rebecca site layout

For personal use only



Roe Site Layout

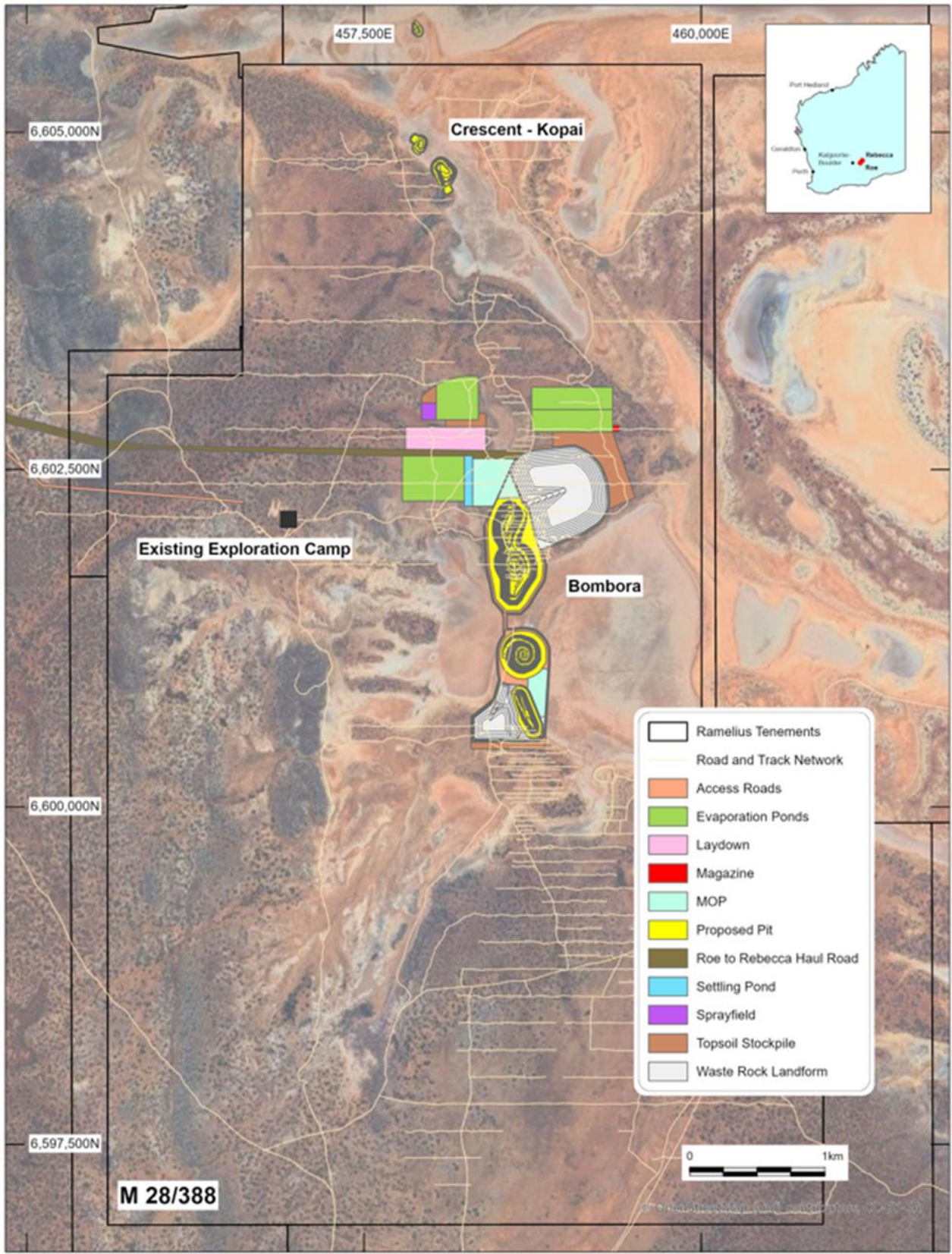

Author: Ramelius Resources | Drawn By: PM | Date: October 2025 | Projection: GDA 2020 Zone 51 | Drawing No: Rebecca - Roe Gold Project_Sept 2025.aprx

Figure 10: Roe site layout

For personal use only



9. GEOTECHNICAL

9.1 Open Pits

Experienced geotechnical consultants have selected geotechnical design domain delineation based on interpreted rock weathering boundaries. Material and rock mass quality is indicated to be relatively consistent within the transported, base of complete oxidation and top of fresh rock (and below) weathering domains across the deposits.

The base case wall design parameters nominated in Table 11 were used in planned pits at the Rebecca, Duchess, Duke and Bombora deposits.

Table 11: Open pit IRA wall angles

Pit	Transported	Highly Weathered	Transitional	Fresh
Rebecca	29.2°	36.7°	39.8°	58.3°
Cleo	29.2°	36.7°	39.8°	58.3°
Duchess	29.2°	36.7°	39.8°	58.3°
Duke	29.2°	36.7°	39.8°	58.3°
Bombora	29.2°	36.7°	42.3°	54.5°

9.2 Roe Underground

Average depth to the Top of Fresh Rock (TOFR) is interpreted to be ~25m (below natural surface).

Rocks within the proposed Bombora Underground mining areas essentially comprise quartz dolerite (MDQ and MQD), lamprophyre (ULP and ALP) and dolerite (MDZ and MD).

MDQ rocks are generally extremely strong (UCS > 250 MPa).

ULP rocks are generally very strong (UCS 100 to 250 MPa).

Within assessed geotechnical domains, first quartile Q-values indicate that the rock mass is typically of good (or better) quality.

Limited intervals of very poor-quality rock are recorded across assessed domains and these zones are generally related to drill intersections of discrete shear structures, often comprising broken rock and smooth chlorite infilled defect surfaces.

Geotechnical assessment has endorsed long hole open stoping without backfill. Planned development is generally placed within fair or better rocks and will be supported with mesh and friction bolts. Some cable bolts will be required for stope brow support.

10. METALLURGY

Comprehensive metallurgical test work has been conducted across the Rebecca, Duchess, Duke, and Roe deposits through multiple programs, each employing varied recovery conditions.

These programs have consistently aimed to establish key metallurgical characterisation parameters, including:

- Comminution
- Mineralogy
- Grind establishment



- Gravity concentration
- Cyanide leaching
- Cyanide detoxification
- Thickening rheology
- Variability test work

In collaboration with an independent engineering firm, Ramelius has designed and executed two major test work programs. These have generated the bulk of the data underpinning the development of the process plant design criteria and the subsequent engineering of the plant.

Table 12 details comminution test work results that has been conducted on samples from Rebecca and Roe, consisting of Abrasion Index, bond ball mill and rod mill work indices as well as SMC test work.

Table 12: Rebecca Roe comminution test work results

Work Indices	Unit	Rebecca	Roe
Abrasion Index	n/a	0.41 to 0.61	0.27 to 0.34
Bond Ball Mill Work Index	kWh/t	16.4 to 18.3	12.7 to 17.2
Bond Rod Mill Work Index	kWh/t	11.9 to 15.6	14.2 to 17.0
SMC (A x b)	n/a	35 to 57	28 to 38

Testwork completed to date for Rebecca and Roe show that there are no deleterious elements present at significant levels. Gravity and cyanidation test work showed that the ore is free milling with considerable free gold present. Table 13 summarises the gravity and leach recoveries across various ore sources at P80 grind size of 75µm and a residence time of 24 hours.

Table 13: Gold recovery by ore source

Ore Source	Gold Recovery
Rebecca	91.2%
Roe (Bombora open pit & underground) Oxide	94.0%
Roe (Bombora open pit & underground) Fresh	91.7%
Overall Recovery	91.5%

Generally, all tests achieve high overall gold recoveries with low gold remaining in the leach residue. Gravity recoverable gold for Rebecca and Roe averages 47.5%.

Test work was performed in hypersaline water with a TDS of 237,000mg/l, which is considered high, even by goldfields hypersaline standards. This level of salinity will contribute to elevated cyanide and lime consumption.

Throughout the test work programs, cyanide consumption has been determined to be 1.13kg/t driven by metallurgical characteristics and water quality whereby lime consumption has been determined to be 4.46kg/t principally driven by water quality.

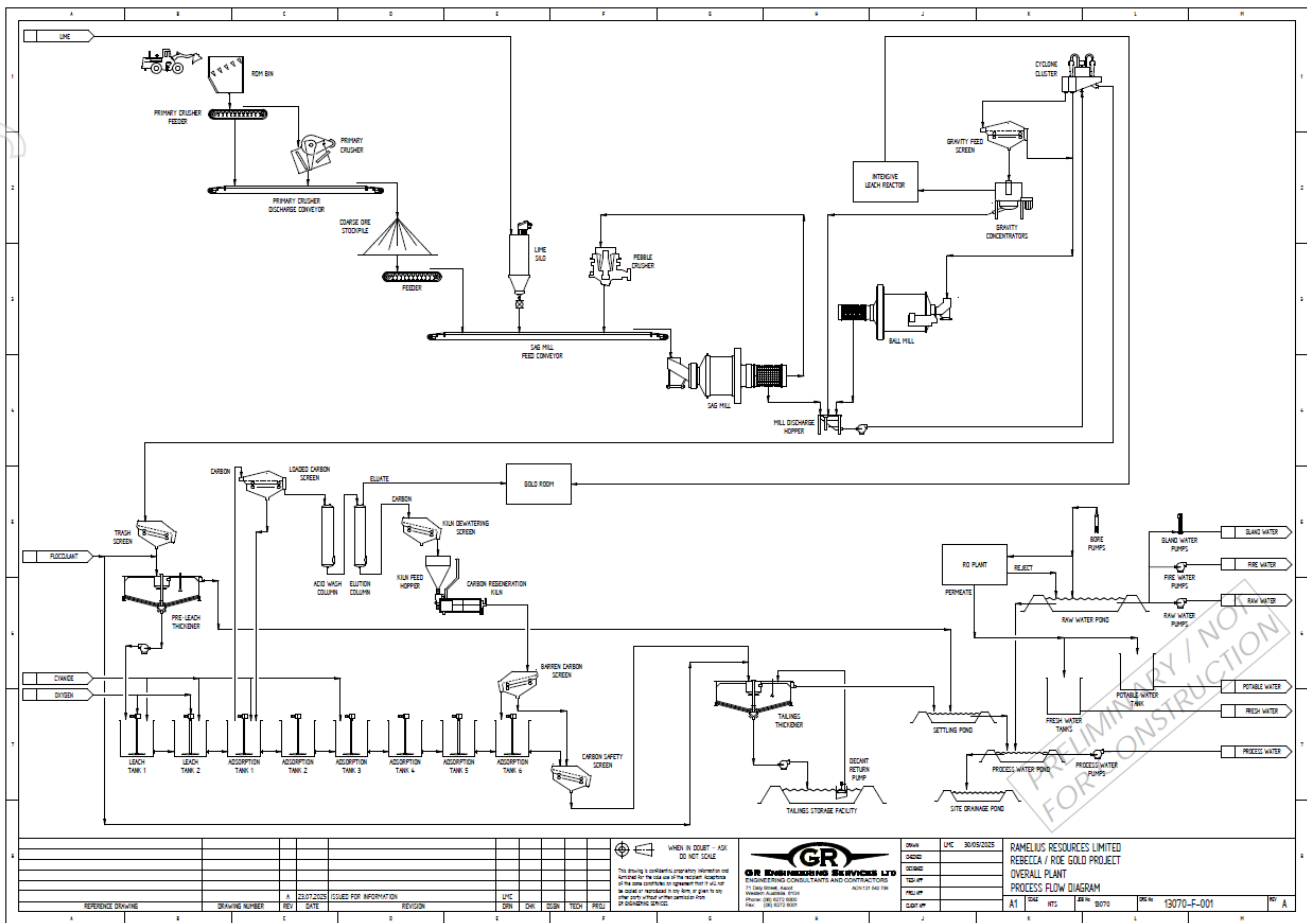

Figure 12: Rebecca process plant process flow diagram

10.2 Capital Costs (Process Plant)

The estimates have been compiled in Australian dollars (A\$) and the base date adopted is the second Quarter (Q2) of FY26. This includes a growth (engineer’s contingency) allowance of 10% but excludes owner’s contingency. The estimate is summarised in Table 14 below.

Table 14: Rebecca processing plant capital costs

Type	Area	Total Project Cost A\$M
DIRECT COSTS	Earthworks	2
	Supply, construction / installation	99
	Electrical installations	21
	Piping	14
	Buildings	4
	Construction equipment	15
Direct Costs Total	Direct Costs Total	155
INDIRECT COSTS	Temporary construction facilities	2
	Supervision and construction management	10
	Project and procurement management	5
	Engineering design	11
	Commissioning	2
	EPC indirect costs	3
Indirect Costs Total	Indirect Costs Total	33
GRAND TOTAL	GRAND TOTAL	188



10.3 Operating Costs (Process Plant)

The operating cost estimate was compiled on the basis that the processing plant will be treating 3.25Mtpa. Ore will be treated by crushing, grinding, gravity concentration, leaching and adsorption, elution, electrowinning and smelting to produce a gold bar.

Table 15 below provides a summary of the operating cost estimate by plant area.

Table 15: Rebecca Processing Plant Operating Costs

Description for 3.25Mtpa Plant	Cost A\$M	Cost A\$/t
Crushing and screening	3.6	1.10
Grinding and classification	44.8	13.79
Leaching, adsorption and elution	27.8	8.56
Tailings	1.0	0.31
Workshop	4.6	1.41
Administration	4.4	1.35
Potable water supply	5.9	1.81
Total Cost	92.1	28.33

11. TAILINGS AND SURFACE WATER MANAGEMENT

The TSF will comprise a two-cell paddock storage formed by multi-zoned earthfill embankments (see Figure 13). The facility is designed to store a total of 30Mt of tailings at an average rate of 3.25Mtpa, with capacity to contain all supernatant and runoff from rainfall events and storm events.

The embankment will be constructed in stages, with the core zones being constructed by a specialised earthworks contractor and the structural embankment being progressively constructed by the mining fleet as part of the mine waste operations from the open pits.

Downstream raise construction methods will be utilised for all Stage 1 TSF embankment raises. The remaining raises will utilise downstream construction methods with the exception of the western embankment which will be raised using upstream construction methods.

The surface water management plan has assessed the stormwater drainage conditions taking into consideration rainfall events across the project area. This plan utilises diversion channels and bunds and Sediment Control Structures to minimise the impact of rainfall events on the operation and on the flow of surface water to their final destinations.



Rebecca Site Layout

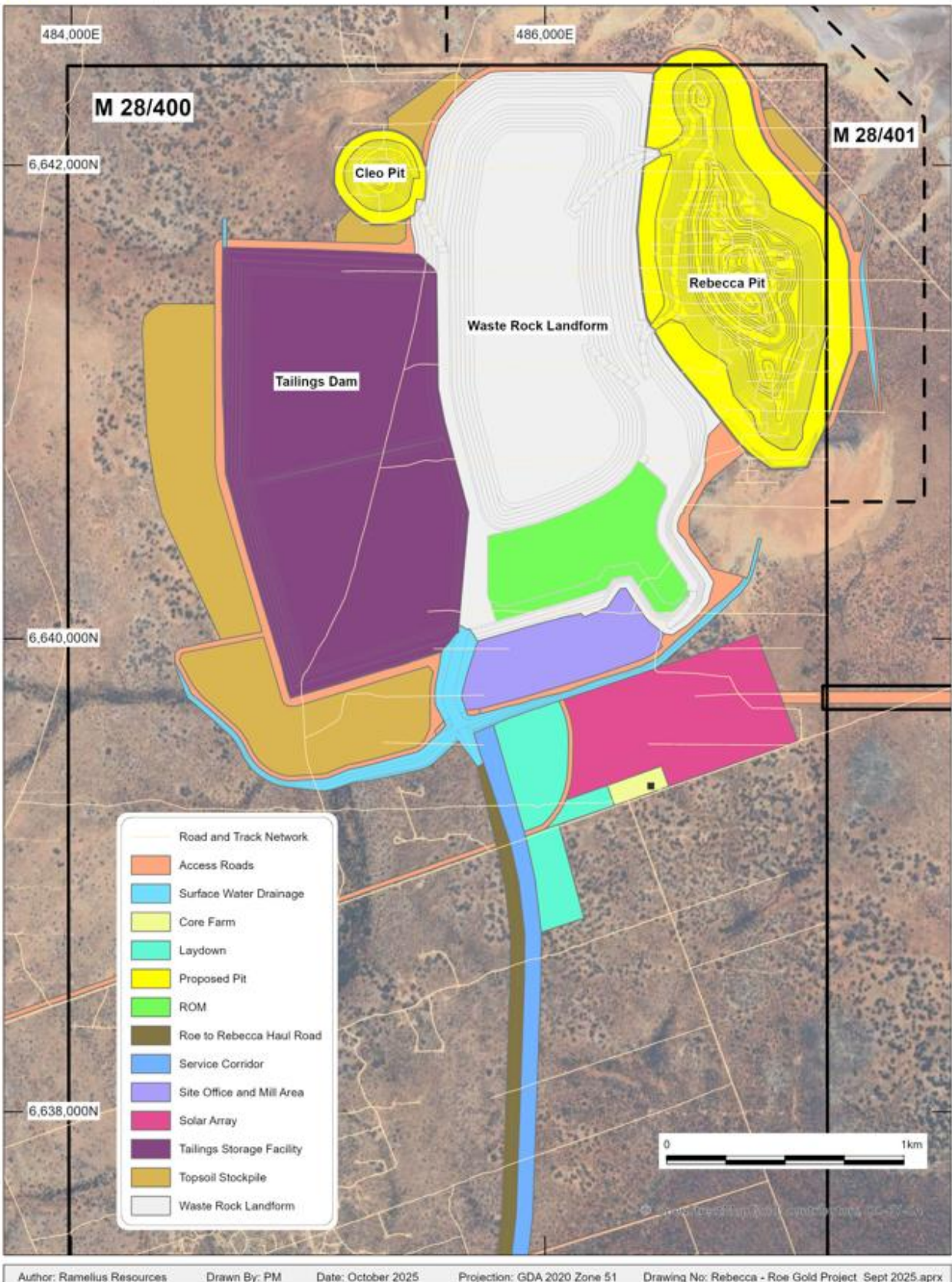

Author: Ramelius Resources Drawn By: PM Date: October 2025 Projection: GDA 2020 Zone 51 Drawing No: Rebecca - Roe Gold Project_Sept 2025.aprx

Figure 13: Rebecca TSF and process plant general arrangement

For personal use only



12. NON-PROCESS INFRASTRUCTURE

12.1 Mine Infrastructure

Mining activities will be supported through the establishment of mining administration offices, mine workshop and warehouse, mine vehicle wash-down facility, waste oil storage tank and the related hardstand and light vehicle parking areas.

A mining equipment workshop and warehouse facility will be established at both sites using igloo-style construction, with sea container support perimeters and combined steel frame and canvass canopy roof structures. Heavy vehicle wash-down pad (with oily water separator) will be constructed adjacent to the open pit workshop. At Roe, there will also be a separate workshop facility for the underground contractor.

12.2 Power Supply and Distribution

Power station situated adjacent to the Rebecca process plant will be a Build Own Operate (BOO) facility. Allowances have been made in the capital cost estimate to establish the facility components that are not covered under the BOO contract arrangement.

It is proposed that Ramelius incorporate a hybrid power station consisting of both solar and thermal power generation and Battery Energy Storage System (BESS).

Proposed hybrid power station:

- Solar farm
 - Rated at 29.05 MWp
 - BESS – rated at 12.5 MW / 25 MWh
- Thermal plant
 - Gas fuelled - 23.57 MW
 - Diesel fuelled – 3.21 MW

In addition, a 10 MW gas fuelled power station is envisaged to power the Bombora underground mine at Roe.

12.3 Aerodrome

An aerodrome will be established to service the Project. The Aerodrome is to be sealed and constructed to the required CASA regulations for Code 3C aircraft.

Aerodrome design parameters:

- Design aircraft – Dash-8 Q400 and Embraer E190
- Runway length – 2,000m
- Runway width – 30m
- Runway pavement type – sealed

12.4 Accommodation

A single accommodation complex will be constructed to service both Rebecca and Roe located approximately 12 km south of Rebecca. The Rebecca village will have a capacity of 460 rooms with construction staged to maximise occupancy. The size of the Rebecca village has included allowances for the periodic requirement for shut down and project workforces due to remoteness of the operation from other operations and regional centres.



12.5 Borefield

The water demand for the Rebecca process plant is approximately 3GL/yr (90L/s). A viable source of groundwater sufficient to meet this demand is the regional Rebecca palaeochannel aquifer system, which roughly underlies the current extended Lake Rebecca drainage system. Water supply targets have been identified within the palaeochannel or its palaeo-tributary channels located outside the Lake Rebecca playa itself.

Water exploration programs are continuing across the Rebecca and Roe tenure.

13. FINANCIALS

13.1 Key Assumptions

Key financial inputs used in the evaluation are as follows:

- A gold price of A\$3,250/oz has been used for generation of open pit and underground cut-off grades
- A gold price of A\$4,500/oz has been assumed as the base case for the financial model
- A discount rate of 5% has been used for NPV calculations
 - A diesel fuel price of A\$1.00/L (excluding GST and fuel excise)
 - A 13.4% mining cost contingency has been applied

13.2 Plant and Equipment Capital

The capital cost estimate has been developed for the design and construction of a 3.25Mtpa gold processing facility and all associated infrastructure. The total Plant and Equipment Capital (infrastructure required to support mining) is estimated at A\$382M (refer Table 16).

Table 16: Plant & equipment capital

Plant & Equipment Capital	Growth A\$M	Sustaining A\$M
Open pit mining	13	-
Underground mining	12	3
TSF	18	29
Roads	12	-
Accommodation	52	-
Process plant	188	8
Aerodrome	15	-
Communications	-	2
Vehicles	5	-
Surface water, bore fields and pumping	25	-
Total Plant & Equipment Capital	340	42

13.3 Operating Cost Estimate

Mining cost estimates were prepared based on existing mining contractor rates at Mt Magnet and project specific pricings received from experienced open pit and underground mining contractors.

Processing costs and site administration cost estimates were prepared by Ramelius based on existing operations and pricings received through the current EPC tender for the Rebecca processing plant.



Table 17 summarises RRGP costs by activity.

Table 17: Cost summary

RRGP Cost Summary	Total A\$M	A\$/t Ore	A\$/t moved	A\$/BCM	A\$/rec. oz
Total open pit mining cost	1,260	\$60	\$7	\$16	\$1,572
Total underground mining cost	650	120			\$2,280
Ore rehandle / haulage cost	116	\$4			\$106
Site administration cost	112	\$4			\$104
Processing cost	744	\$28			\$685
Royalty costs	206	\$8			\$190
Total cash costs (open pit & underground)	3,088	\$118			\$2,843
Less: capitalised pre-production – open pit	(215)	(\$10)			(\$268)
Less: capitalised pre-production – underground	(64)	(\$12)			(\$226)
PE capital cost – sustaining	42	\$2			\$39
Total cash Opex (AISC)	2,852	\$109			\$2,625
Add: capitalised pre-production – open pit	215	\$10			\$268
Add: capitalised pre-production – underground	64	\$12			\$226
PE capital cost - growth	340	\$13			\$313
Total costs (AIC)	3,471	\$132			\$3,195

13.4 Financials Over Life of Mine

The below tables breakdown physical production and financial results over the life of mine.



Table 18: Production highlights by financial years

Production highlights	Unit	FY27	FY28	FY29	FY30	FY31	FY32	FY33	FY34	FY35	FY36	FY37	LOM
Open pit mining													
Material moved	Kbcm	-	8,181	19,018	16,102	11,162	7,265	5,887	5,670	4,301	1,773	-	79,359
Strip ratio (high-grade ore)	w:o	-	166.8	39.1	14.5	16.1	18.0	7.7	6.2	20.1	11.4	-	17.0
High-grade													
Ore tonnes	Kt	-	118	1,232	2,886	1,789	1,043	1,853	2,129	544	383	-	11,978
Grade	g/t	-	1.47	1.64	1.89	1.83	1.93	1.71	1.81	1.38	1.29	-	2.26
Contained gold	Koz	-	6	87	216	134	86	128	145	36	35	-	872
Low-grade													
Ore tonnes	Kt	-	217	1,011	1,863	1,268	992	1,149	918	567	882	-	8,866
Grade	g/t	-	0.64	0.69	0.69	0.70	0.66	0.70	0.70	0.64	0.68	-	0.69
Contained gold	Koz	-	4	22	41	28	21	26	21	12	19	-	195
Underground mining													
Ore tonnes	Kt	-	-	-	-	6	600	1,236	1,202	1,192	998	186	5,420
Grade	g/t	-	-	-	-	0.68	1.72	1.62	1.74	1.83	2.01	1.84	1.78
Contained gold	Koz	-	-	-	-	0	33	64	67	70	65	11	311
Processing													
Tonnes	Kt	-	-	2,155	3,250	3,250	3,259	3,250	3,250	3,250	3,259	1,341	26,263
Grade	g/t	-	-	1.27	1.55	1.43	1.36	1.49	1.43	1.64	1.26	0.82	1.41
Contained gold	Koz	-	-	88	162	150	143	155	150	172	132	36	1,187
Recovery	%	0.0%	0.0%	92.6%	91.5%	91.4%	91.3%	91.4%	91.3%	91.6%	91.4%	91.4%	91.5%
Gold production	Koz	-	-	81	148	137	130	142	137	157	121	32	1,086



Table 19: Financial highlights by financial years

Financial highlights (@ A\$4,500/oz)	Unit	FY27	FY28	FY29	FY30	FY31	FY32	FY33	FY34	FY35	FY36	FY37	LOM
Cash flow													
Cash flow (pre-tax)	\$M	(22)	(321)	(42)	262	242	198	205	210	340	280	67	1,418
Cash flow (post-tax)	\$M	(22)	(321)	(42)	234	183	155	160	163	256	214	58	1,037
Unit costs													
AISC (pre-corporate)	\$/Oz	\$ -	\$ -	\$ 3,536	\$ 2,206	\$ 2,308	\$ 3,091	\$ 2,905	\$ 2,020	\$ 2,969	\$ 2,356	\$ 2,396	\$ 2,625
AISC (pre-corporate)	\$/t	\$ -	\$ -	\$ 134	\$ 101	\$ 97	\$ 124	\$ 127	\$ 85	\$ 144	\$ 87	\$ 58	\$ 109
AIC (pre-corporate)	\$/Oz	\$ -	\$ -	\$ 5,373	\$ 2,485	\$ 2,748	\$ 3,258	\$ 2,905	\$ 2,080	\$ 3,113	\$ 2,356	\$ 2,414	\$ 3,195
Open pit mining cost	\$/bcm	\$ 11	\$ 12	\$ 16	\$ 16	\$ 21	\$ 24	\$ 20	\$ 15	\$ 21	\$ -	\$ -	\$ 16
Underground mining cost	\$/t	\$ -	\$ -	\$ -	\$ -	\$ 6,112	\$ 152	\$ 112	\$ 121	\$ 116	\$ 76	\$ 110	\$ 120
Haulage cost	\$/t	\$ -	\$ -	\$ 6	\$ 5	\$ 2	\$ 3	\$ 4	\$ 2	\$ 9	\$ 5	\$ 4	\$ 4
Milling cost	\$/t	\$ -	\$ -	\$ 28	\$ 28	\$ 28	\$ 28	\$ 28	\$ 28	\$ 28	\$ 28	\$ 28	\$ 28
Admin cost (tonne milled)	\$/t	\$ -	\$ -	\$ 4	\$ 3	\$ 4	\$ 5	\$ 5	\$ 5	\$ 4	\$ 4	\$ 4	\$ 4
Cash flow													
Gold sales	Koz	-	-	81	148	137	130	142	137	157	121	32	1,086
Gold price	\$/Oz	\$ -	\$ -	\$ 4,500	\$ 4,500	\$ 4,500	\$ 4,500	\$ 4,500	\$ 4,500	\$ 4,500	\$ 4,500	\$ 4,500	\$ 4,500
Revenue	\$M	-	-	366	668	616	587	639	616	707	543	146	4,888
Operating costs	\$M	-	(95)	(329)	(402)	(357)	(383)	(429)	(399)	(361)	(258)	(76)	(3,088)
Capital costs	\$M	(22)	(226)	(80)	(4)	(17)	(6)	(6)	(8)	(5)	(5)	(3)	(382)
Net cash flow (pre-tax)	\$M	(22)	(321)	(42)	262	242	198	205	210	340	280	67	1,418
Cumulative net cash flow (pre-tax)	\$M	(22)	(343)	(385)	(124)	118	316	521	730	1,071	1,350	1,418	1,418
Income tax payments	\$M	-	-	-	(28)	(59)	(43)	(45)	(47)	(85)	(66)	(10)	(381)
Net cash flow (post-tax)	\$M	(22)	(321)	(42)	234	183	155	160	163	256	214	58	1,037
Cumulative net cash flow (post-tax)	\$M	(22)	(343)	(385)	(151)	32	187	347	510	765	980	1,037	1,037



Table 20: AISC by financial years

AISC (pre-corporate costs)	Unit	FY27	FY28	FY29	FY30	FY31	FY32	FY33	FY34	FY35	FY36	FY37	LOM
Mining	\$M	-	-	183	215	170	219	281	251	179	113	20	1,630
Milling & haulage	\$M	-	-	74	108	100	101	106	98	120	109	44	860
Movement in inventories	\$M	-	-	-	(37)	2	36	(22)	(122)	122	21	-	(0)
Administration	\$M	-	-	14	10	13	15	15	15	14	14	5	113
Royalties	\$M	-	-	15	28	27	26	27	29	26	22	6	206
Sustaining capital	\$M	-	-	3	4	5	6	6	6	5	5	2	42
Total AISC (pre-corporate costs)	\$M	-	-	288	328	316	403	413	276	466	284	78	2,852
Growth capital - plant & equipment	\$M	22	226	78	-	12	-	-	1	-	-	1	340
Growth capital - mine development	\$M	-	66	72	42	48	22	-	7	23	-	-	279
Total AIC (pre-corporate costs)	\$M	22	292	437	369	376	425	413	285	489	284	78	3,471
Ounces sold	Koz	-	-	81	148	137	130	142	137	157	121	32	1,086
AISC	\$/Oz	-	-	3,536	2,206	2,308	3,091	2,905	2,020	2,969	2,356	2,396	2,625
AIC	\$/Oz	-	-	5,373	2,485	2,748	3,258	2,905	2,080	3,113	2,356	2,414	3,195
AISC (per tonne)	\$/t	\$ -	\$ -	\$ 134	\$ 101	\$ 97	\$ 124	\$ 127	\$ 85	\$ 144	\$ 87	\$ 58	\$ 109



14. SENSITIVITY ANALYSIS

The forecast free cash flow and net present value (post capex, pre-tax and post-tax) changes with the gold price are detailed in Table 21.

Table 21: Forecast free cash flow

Sensitivity Analysis				
Gold Price LOM	Free Cash Flow (pre-tax) A\$M	Free Cash Flow (post-tax) A\$M	NPV (pre-tax) ^{5%} A\$M	NPV (post-tax) ^{5%} A\$M
A\$4,500/oz (base case)	1,418	1,037	970	692
A\$5,250/oz	2,199	1,583	1,563	1,107
A\$6,000/oz	2,979	2,130	2,157	1,523

15. EXTERNAL STAKEHOLDERS

External stakeholders who may be impacted by project development including Pastoral Lease Holders and Native Title Parties have been identified. Ramelius is in consultation with each of these parties and discussions are well progressed.

A Heritage Protection Agreement has been executed with the main Native Title Party and negotiations are currently underway for a Native Title Mining Agreement.

16. REBECCA-ROE-YINDI EXPLORATION UPSIDE

At Rebecca, ongoing exploration activities are focussed along strike of the Rebecca, Duchess and Cleo deposits, along granite-greenstone contacts to the south-west as well as on interpreted banded iron formations (under cover) over the western part of the tenure (refer Figure 14).

At Roe, exploration activities are focussed to the south and north of the Bombora (Roe) deposits (following up anomalous surface geochemical results), as well as west/north-west of Bombora along granite-greenstone contacts.

At Yindi project (immediately north of Roe project), exploration will focus on several major structural fault zones that have been identified.

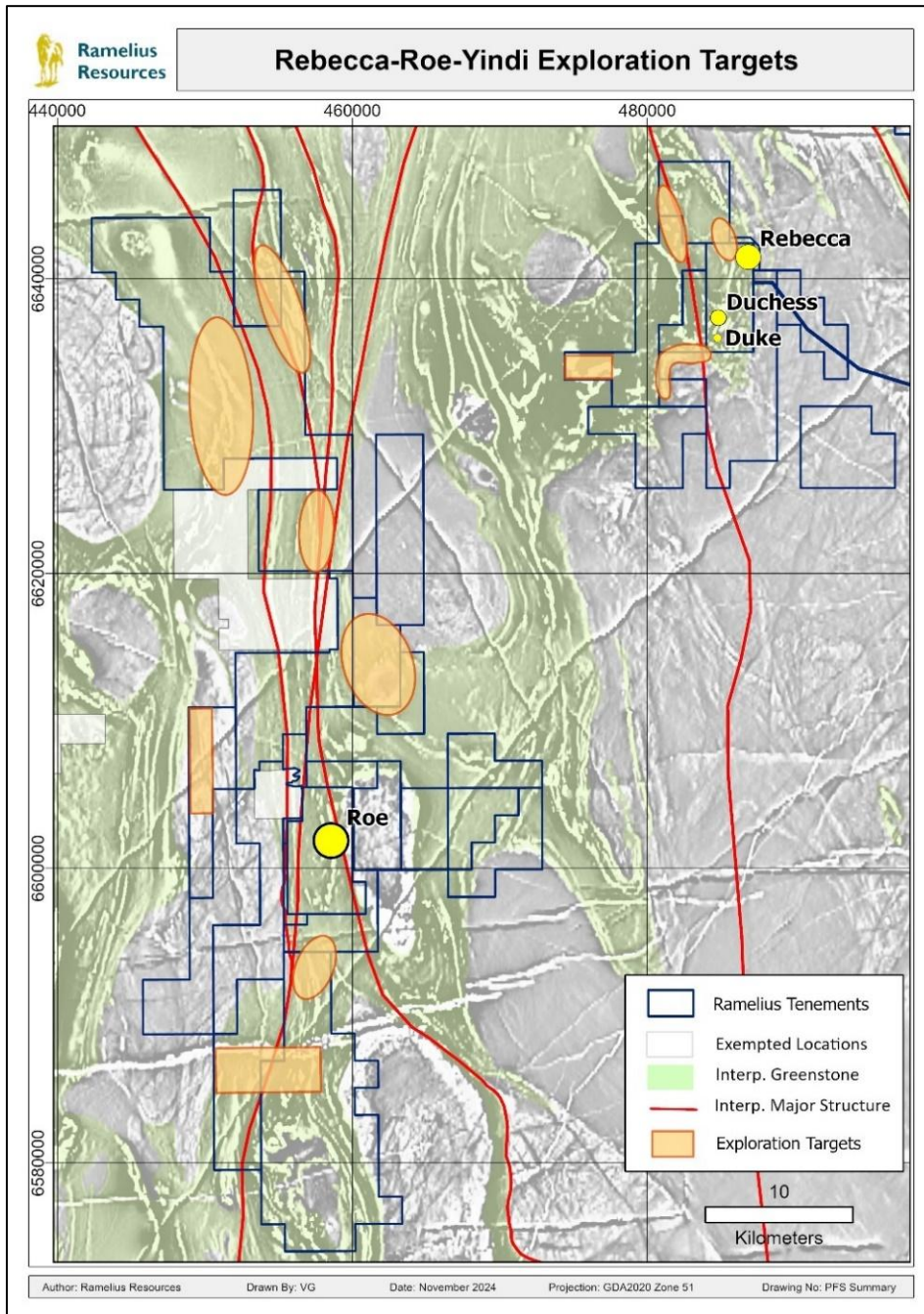

Figure 14: Interpreted Greenstone Belt and major structures showing exploration target areas over the Rebecca-Roe Gold Project

17. RISKS

The Company considers that the following list, which is not exhaustive, represents some of the key risk factors relevant to the development of the project proposed by the DFS. Further risk factors apply to the Company and its business (such as those previously announced to the ASX by the Company).

Gold Price Volatility and Exchange Rate Risk

The project is financially robust with strong free cash flows. Of all variables, the financial outcome is most impacted by changes to revenue factors. Negative changes to the recovered gold or Australian dollar gold price, either by US dollar gold price variation or AUD:USD exchange rate fluctuations, would have a direct effect on revenue and derived cash flow.



Resource and Reserve Estimates

Resource and Reserve estimates are expressions of judgement based on knowledge, experience and industry practice, including compliance with the 2012 JORC Code. By their very nature, these estimates are imprecise and depend on interpretations that may prove to be inaccurate which means that the reconciliation and performance of the Reserve model is a risk that is inherent until production confirms the modelling. Major variances to contained metal in the Reserve will have a negative impact on the revenue generated by the project.

Approval Risks

The Company will be reliant on environmental and other regulatory approvals to enable it to proceed with the development of the project. There is no guarantee that the required approvals will be granted, and delays in project permitting may delay the project from commencing production in the proposed timeframe. Early engagement with regulators to raise awareness of the project and the planned scope is ongoing.

Environmental, Health and Safety Risks

The Company expends significant financial and managerial resources to keep our stakeholders safe and to comply with a complex set of environmental, health and safety laws, regulations, guidelines and permitting requirements. The historical trend that the Company observes is toward stricter laws and the Company expects this trend to continue. The possibility of more stringent laws or more rigorous enforcement of existing laws exists in the areas of worker health and safety, the disposition of wastes, the decommissioning and reclamation of mining sites, restriction of areas where exploration, development and mining activities may take place, consumption and treatment of water and other environmental matters, each of which could have a material adverse effect on the Company's exploration activities, operations and the cost or the viability of a particular project.

Personnel and Operating Costs

The Western Australian resource economy is currently very active with strong commodity prices. As a result, the skilled labour pool (management, technical and blue collar) is relatively inelastic.

The cost of energy, labour, materials, services and other operating inputs are at historically high levels on a unit basis and inflationary pressures remain and may impact estimated operating costs in the DFS.

Supply Chain

The project is located in a remote location and requires long lead time for equipment and supplies. It is dependent on an uninterrupted flow of materials, supplies and services. Any interruptions to the procurement of equipment, or the flow of materials, supplies and services could have an adverse impact on its future cash flows.

The Company will rely significantly on strategic relationships with material, equipment and service providers. The Company will also rely on third parties to provide essential contracting services. There can be no assurance that its existing relationships will continue to be maintained or that new ones will be successfully formed. The project could be adversely affected by changes to such relationships or difficulties in forming new ones.



Development and Construction Risks

Construction costs and timelines can be impacted by a wide variety of factors, many of which are beyond the Company's control. These include, but are not limited to, weather and ground conditions, performance of the mining contractor fleet and availability of appropriate materials required for construction, availability and performance of contractors and suppliers, delivery and installation of equipment, design changes, accuracy of estimates, global capital cost inflation, local in-country inflation and availability of accommodations for the workforce. Development schedules are also dependent on obtaining the governmental approvals necessary for the operation of a project. The timeline to obtain these government approvals is often beyond the control of the Company. A delay in start-up or commercial production would increase capital costs and delay receipt of revenues.

The ultimate and continued success of the project is dependent on a number of factors, including the construction of efficient development and production infrastructure within capital expenditure budgets and on schedule.

Operational Risks

The Company's operations may be delayed or prevented as a result of various factors, including weather conditions, mechanical difficulties or a shortage of technical expertise or equipment.

There may be difficulties with obtaining government and/or third-party approvals; operational difficulties encountered with construction, extraction and production activities; unexpected shortages or increase in the price of consumables, plant and equipment; or cost overruns. The Company's operations may be curtailed or disrupted by risks beyond its control, such as environmental hazards, industrial accidents and disputes, technical failures, unusual or unexpected geological conditions, adverse weather conditions, fires, explosions and other accidents.

The occurrence of any of these circumstances could result in the Company not realising its operational or development plans or in such plans costing more than expected or taking longer to realise than expected. Any of these outcomes could have an adverse effect the Company's financial and operational performance.

18. FORWARD LOOKING STATEMENTS

This report contains forward looking statements. The forward-looking statements are based on current expectations, estimates, assumptions, forecasts and projections and the industry in which it operates as well as other factors that management believes to be relevant and reasonable in the circumstances at the date such statements are made, but which may prove to be incorrect. The forward-looking statements relate to future matters and are subject to various inherent risks and uncertainties. Many known and unknown factors could cause actual events or results to differ materially from the estimated or anticipated events or results expressed or implied by any forward-looking statements. Such factors include, among others, changes in market conditions, future prices of gold and exchange rate movements, the actual results of production, development and/or exploration activities, variations in grade or recovery rates, plant and/or equipment failure and the possibility of cost overruns. Neither Ramelius, its related bodies corporate nor any of their directors, officers, employees, agents or contractors makes any representation or warranty (either express or implied) as to the accuracy, correctness, completeness, adequacy, reliability or likelihood of fulfilment of any forward-looking statement,



or any events or results expressed or implied in any forward-looking statement, except to the extent required by law.

19. PREVIOUSLY REPORTED INFORMATION

Information in this report references previously reported exploration results and resource information extracted from the Company's ASX announcements. For the purposes of ASX Listing Rule 5.23 the Company confirms that it is not aware of any new information or data that materially affects the information included in the original market announcements and that all material assumptions and technical parameters underpinning the estimates in the relevant market announcements continue to apply and have not materially changed.

20. COMPETENT PERSONS

The information in this report that relates to Exploration Results, Mineral Resources and Ore Reserves is based on information compiled by Peter Ruzicka (Exploration Results), Jake Ball (Mineral Resources) and Paul Hucker (Ore Reserves), who are Competent Persons and Members of The Australasian Institute of Mining and Metallurgy. Peter Ruzicka, Jake Ball and Paul Hucker are full-time employees of the company. Peter Ruzicka, Jake Ball and Paul Hucker have sufficient experience that is relevant to the style of mineralisation and type of deposit under consideration and to the activity being undertaken to qualify as a Competent Person as defined in the 2012 Edition of the "Australasian Code for Reporting of Exploration Results, Mineral Resources and Ore Reserves". Peter Ruzicka, Jake Ball and Paul Hucker consent to the inclusion in this report of the matters based on their information in the form and context in which it appears.



21. JORC TABLE 1 REPORT FOR EXPLORATION & MINERAL RESOURCES

Section 1 Sampling Techniques and Data

Criteria	JORC Code explanation	Commentary
Sampling techniques	<ul style="list-style-type: none"> Nature and quality of sampling (e.g. cut channels, random chips, or specific specialised industry standard measurement tools appropriate to the minerals under investigation, such as down hole gamma sondes, or handheld XRF instruments, etc). These examples should not be taken as limiting the broad meaning of sampling. Include reference to measures taken to ensure sample representivity and the appropriate calibration of any measurement tools or systems used. Aspects of the determination of mineralisation that are Material to the Public Report. In cases where 'industry standard' work has been done this would be relatively simple (e.g. 'reverse circulation drilling was used to obtain 1 m samples from which 3 kg was pulverised to produce a 30 g charge for fire assay'). In other cases more explanation may be required, such as where there is coarse gold that has inherent sampling problems. Unusual commodities or mineralisation types (e.g. submarine nodules) may warrant disclosure of detailed information. 	<ul style="list-style-type: none"> At all projects potential gold mineralised RC and Diamond intervals are systematically sampled using industry standard 1m intervals, collected from reverse circulation (RC) drill holes and/or 4m composites from reconnaissance Aircore traverses. Surface and underground Diamond holes may be sampled along sub 1m geological contacts, otherwise 1m intervals are the default. Drill hole locations were designed to allow for spatial spread across the interpreted mineralised zone. All RC samples were collected and cone-split to 2-3kg samples on 1m metre intervals. Aircore samples are speared from 1m interval piles on the ground or from 1m interval bags and are composited into 4m intervals before despatching to the laboratory. Single metre bottom of hole Aircore samples are also collected for trace element determinations. Diamond core is half cut along downhole orientation lines, with the exception of underground diamond drilling. Here, whole core is despatched to the laboratory to maximise the sample size. Otherwise, half core is sent to the laboratory for analysis and the other half is retained for future reference. Standard fire assaying was employed using a 50gm charge with an AAS finish for all diamond, RC and Aircore chip samples. Trace element determination was undertaken using a multi (4) acid digest and ICP- AES finish. Roe diamond holes drilled in 2024 were photon assayed using whole core samples that were crushed to 90% passing 3.15mm and split into 500g aliquot jars for analysis.
Drilling techniques	<ul style="list-style-type: none"> Drill type (e.g. core, reverse circulation, open-hole hammer, rotary air blast, auger, Bangka, sonic, etc) and details (e.g. core diameter, triple or standard tube, depth of diamond tails, face-sampling bit or other type, whether core is orientated and if so, by what method, etc). 	<ul style="list-style-type: none"> Rebecca: Between 1990-2021, 843 holes for 119,000m were drilled by previous owners, primarily RC with 6 DD and approx. 30 DD core tails. Apollo drilled the 626 of these holes, largely post 2018. Ramelius has continued significant RC drilling in 2022 (99 holes for 15,050m) and recently commenced DD tails and DD geotech drilling. Roe: RC drilling was undertaken using a face-sampling percussion hammer with 5½” bits. Diamond core is HQ3, HQ or NQ2. Core is orientated using Reflex orientation tools, with core initially cleaned and pieced together at the drill site and fully orientated by field staff at Lake Roe core yard.
Drill sample recovery	<ul style="list-style-type: none"> Method of recording and assessing core and chip sample recoveries and results assessed. Measures taken to maximise sample recovery and ensure representative nature of the samples. Whether a relationship exists between sample recovery and grade and whether sample bias may have occurred due to preferential loss/gain of fine/coarse material. 	<ul style="list-style-type: none"> All diamond core is jigsawed to ensure any core loss, if present is fully accounted for. Bulk RC and Aircore drill holes samples were visually inspected by the supervising geologist to ensure adequate clean sample recoveries were achieved. Note Aircore drilling while clean is not used in any resource estimation work. Any wet, contaminated or poor sample returns are flagged and recorded in the database to ensure no sampling bias is introduced.



Criteria	JORC Code explanation	Commentary
		<ul style="list-style-type: none"> Zones of poor sample return both in RC and Aircore are recorded in the database and cross checked once assay results are received from the laboratory to ensure no misrepresentation of sampling intervals has occurred. Of note, excellent RC drill recovery is reported from all RC holes. Reasonable recovery is noted for all Aircore samples. Zero sample recovery is achieved while navi drilling. The navi lengths are kept to a minimum and avoided when close to potentially mineralised units. No indication of sample bias is evident or has been established.
Logging	<ul style="list-style-type: none"> Whether core and chip samples have been geologically and geotechnically logged to a level of detail to support appropriate Mineral Resource estimation, mining studies and metallurgical studies. Whether logging is qualitative or quantitative in nature. Core (or costean, channel, etc) photography. The total length and percentage of the relevant intersections logged. 	<ul style="list-style-type: none"> All drill samples are geologically logged on site by professional geologists. Details on the host lithologies, deformation, dominant minerals including sulphide species and alteration minerals plus veining are recorded relationally (separately) so the logging is interactive and not biased to lithology. Drill hole logging is qualitative on visual recordings of rock forming minerals and quantitative on estimates of mineral abundance. The entire length of each drill hole is geologically logged.
Sub-sampling techniques and sample preparation	<ul style="list-style-type: none"> If core, whether cut or sawn and whether quarter, half or all core taken. If non-core, whether riffled, tube sampled, rotary split, etc and whether sampled wet or dry. For all sample types, the nature, quality and appropriateness of the sample preparation technique. Quality control procedures adopted for all sub-sampling stages to maximise representivity of samples. Measures taken to ensure that the sampling is representative of the in situ material collected, including for instance results for field duplicate/second-half sampling. Whether sample sizes are appropriate to the grain size of the material being sampled. 	<ul style="list-style-type: none"> Core holes are sawn and sampled as half core. Some 1/4 core sampling has occurred as checks. Duplicate samples are collected every 20th sample from the RC and Aircore chips as well as quarter core from the diamond holes. Dry RC 1m samples are riffle split to 2-3kg as drilled and dispatched to the laboratory. Any wet samples are recorded in the database as such and allowed to dry before splitting and dispatching to the laboratory. All core, RC and Aircore chips are pulverized prior to splitting in the laboratory to ensure homogenous samples with 85% passing 75um. 200gm is extracted by spatula that is used for the 50gm or 30 gm charge on standard fire assays. All samples submitted to the laboratory are sorted and reconciled against the submission documents. In addition to duplicates, a selection of appropriate high-grade or low-grade standards and controlled blanks are included every 20th sample. The laboratory uses barren flushes to clean their pulveriser and their own internal standards and duplicates to ensure industry best practice quality control is maintained. The sample size is considered appropriate for the type, style, thickness and consistency of mineralisation.
Quality of assay data and laboratory tests	<p>The nature, quality and appropriateness of the assaying and laboratory procedures used and whether the technique is considered partial or total.</p> <ul style="list-style-type: none"> For geophysical tools, spectrometers, handheld XRF instruments, etc. the parameters used in determining the 	<ul style="list-style-type: none"> The fire assay method is designed to measure the total gold in the diamond core, RC and Aircore samples. The technique involves standard fire assays using a 50gm or 30gm sample charge with a lead flux (decomposed in the furnace). The prill is totally digested by HCl and HNO₃ acids before measurement of the gold determination by AAS.



Criteria	JORC Code explanation	Commentary
	<p>analysis including instrument make and model, reading times, calibrations factors applied and their derivation, etc.</p> <ul style="list-style-type: none"> Nature of quality control procedures adopted (e.g. standards, blanks, duplicates, external laboratory checks) and whether acceptable levels of accuracy (i.e. lack of bias) and precision have been established. 	<p>Aqua regia digest is considered adequate for surface soil sampling.</p> <ul style="list-style-type: none"> Some intervals at Roe have been analysed by Photon analysis of a crushed 500g sample or sub-sample. Photon is a non-destructive technique that utilises high energy X-Rays for gold detection. No field analyses of gold grades are completed. Quantitative analysis of the gold content and trace elements is undertaken in a controlled laboratory environment. Industry best practice is employed with the inclusion of duplicates and standards as discussed above and used by Ramelius as well as the laboratory. All Ramelius standards and blanks are interrogated to ensure they lie within acceptable tolerances. Additionally, sample size, grind size and field duplicates are examined to ensure no bias to gold grades exists. For RRE, analytical determination of each element is reported using peroxide fusion and ICP-MS finish. REE values are converted to REO using the appropriate oxide formulae. TREO refers to the total sum of the REO.
<p>Verification of sampling and assaying</p>	<ul style="list-style-type: none"> The verification of significant intersections by either independent or alternative company personnel. The use of twinned holes. Documentation of primary data, data entry procedures, data verification, data storage (physical and electronic) protocols. Discuss any adjustment to assay data. 	<ul style="list-style-type: none"> Alternative Ramelius personnel have inspected the diamond core, RC and Aircore chips in the field to verify the correlation of mineralised zones between assay results and lithology, alteration and mineralisation. In most projects holes were not twinned deliberately, but there are frequent holes that effectively twin others due to varied drill angles, collar location restrictions or hole density. All resources have holes drilled more recently as a check of older drilling data. Directional “wedging” was used in several deep diamond drill holes at Bombora which results in twinning of parent drill hole intersections in several areas of mineralisation. The density and pattern of RC and diamond drilling also results in twinning of RC intersections by diamond drill holes in several other areas. All holes are digitally logged in the field and all primary data is forwarded to Ramelius’ Database Administrator (DBA) in Perth where it is imported into Datashed, a commercially available and industry accepted database software package. Assay data is electronically merged when received from the laboratory. The responsible project geologist reviews the data in the database to ensure that it is correct and has merged properly and that all the drill data collected in the field has been captured and entered into the database correctly. The responsible geologist makes the DBA aware of any errors and/or omissions to the database and the corrections (if required) are corrected in the database immediately. No adjustments or calibrations are made to any of the assay data recorded in the database.



Criteria	JORC Code explanation	Commentary
Location of data points	<ul style="list-style-type: none"> Accuracy and quality of surveys used to locate drill holes (collar and down-hole surveys), trenches, mine workings and other locations used in Mineral Resource estimation. Specification of the grid system used. Quality and adequacy of topographic control. 	<ul style="list-style-type: none"> All drill collars have been surveyed by DGPS instruments or by accredited surveyors to sub-metre accuracy. At Roe, GPS elevation values are corrected where necessary using a digital elevation model from a LIDAR survey. Expected accuracy is +/- 4m for easting, northing and RL (GPS) and +/- 0.1m or less for surveyed and LIDAR elevation point data. All recent holes were downhole surveyed using electronic camera or gyroscopic survey tools. Rebecca and Roe drill holes are picked up in MGA2020 - Zone 51. DGPS RL measurements captured the collar surveys of the drill holes prior to the resource estimation work.
Data spacing and distribution	<ul style="list-style-type: none"> Data spacing for reporting of Exploration Results. Whether the data spacing and distribution is sufficient to establish the degree of geological and grade continuity appropriate for the Mineral Resource and Ore Reserve estimation procedure(s) and classifications applied. Whether sample compositing has been applied. 	<ul style="list-style-type: none"> Rebecca: Drillholes are orientated orthogonal to the geological and mineralised trend. Intercept angles are often near perpendicular. Typically, as - 60° east dipping holes drilling 40-50° west dipping lodes. Selected metallurgical holes drill down the lodes. RC drill spacing varies depending on stage of the prospect – infill and step out (extensional) programmes are planned on nominal 20m to 40m centres. Good continuity has been achieved from the RC drilling. Bombora: Bombora: Drill holes are on a nominal spacing of 40m x 20m with areas at a 20m x 20m spacing completed every 200 metres along strike in the shallow part of the Bombora resource to ~200-250 meters below surface). Claypan: The drill spacing is on a nominal 200m x 80m reconnaissance pattern. Kopai-Crescent: The drill spacing is on a nominal 100m x 40m with local infill to 40m x 20m in the southern (Crescent) area. Drilling outside the Mineral Resource areas is on an irregular reconnaissance spacing. Drill spacing is sufficient to establish appropriate continuity and the classifications applied. RC: Vast majority of samples are 1m, with minor 2 or 4m composites, generally outside mineralised areas. Diamond: 1m samples or geologically defined 0.3 - 1.5m samples. All data composited to 1m lengths for resource calculations.
Orientation of data in relation to geological structure	<ul style="list-style-type: none"> Whether the orientation of sampling achieves unbiased sampling of possible structures and the extent to which this is known, considering the deposit type. If the relationship between the drilling orientation and the orientation of key mineralised structures is considered to have introduced a sampling bias, this should be assessed and reported if material. 	<ul style="list-style-type: none"> Rebecca: Drillholes are orientated orthogonal to the geological and mineralised trend. Intercept angles are often near perpendicular. Typically, as - 60° east dipping holes drilling 40-50° west dipping lodes. Selected metallurgical holes drill down the lodes. Bombora: Three main mineralised fault (lodes) orientations have been recognised: steep lodes, flat lodes and west lodes. A combination of east- and west-orientated drilling is used overcome potential biasing of west-dipping lodes. Claypan and Kopai-Crescent: The geometry of the flat, north-plunging mineralisation is constrained by diamond drilling and is factored into the modelling. Wider drill spacing introduces the



Criteria	JORC Code explanation	Commentary
		<p>possibility that other mineralised geometries may be present.</p> <ul style="list-style-type: none"> These issues are well understood. No bias considered present for all deposits. Minor potential for orientation bias for some individual holes exists, but no bias is believed evident at deposit scales.
Sample security	<ul style="list-style-type: none"> The measures taken to ensure sample security. 	<ul style="list-style-type: none"> Sample security is integral to Ramelius' sampling procedures. All bagged samples are delivered directly from the field to the assay laboratory in Perth, whereupon the laboratory checks the physically received samples against Ramelius' sample submission/dispatch notes.
Audits or reviews	<ul style="list-style-type: none"> The results of any audits or reviews of sampling techniques and data. 	<ul style="list-style-type: none"> A formal audit and review were conducted on field sampling techniques, data collection and storage procedures by Cube Consultants (February 2018) did not identify any material issues. Scanning of sample quality (recovery, wetness and contamination) as recorded by the geologist on the drill rig against assay results occurs regularly with no obvious issues identified to date. Ongoing reviews of QA/QC data (CRM and duplicate samples) and RC composite v RC split metal content are regularly carried out as a part of RMS standard procedures.

Section 2 Reporting of Exploration Results

Criteria	JORC Code explanation	Commentary
Mineral tenement and land tenure status	<ul style="list-style-type: none"> Type, reference name/number, location and ownership including agreements or material issues with third parties such as joint ventures, partnerships, overriding royalties, native title interests, historical sites, wilderness or national park and environmental settings. The security of the tenure held at the time of reporting along with any known impediments to obtaining a licence to operate in the area. 	<ul style="list-style-type: none"> Rebecca: Rebecca deposits fall within M28/400 owned 100% by RMS subsidiary AC Minerals Pty Ltd. A 1.5% NSR royalty is owned by a 3rd party. Roe: The Roe resources and deposits are located on tenement M28/388 and E28/2515, which are held 100% by Lake Roe Gold Mining Ltd, a wholly owned subsidiary of RMS. Currently all the tenements are in good standing. There are no known impediments to obtaining licences to operate in all areas. Additional Mining Lease applications are in progress.
Exploration done by other parties	<ul style="list-style-type: none"> Acknowledgment and appraisal of exploration by other parties. 	<ul style="list-style-type: none"> Exploration by other parties has been reviewed and is used as a guide to Ramelius' exploration activities. Previous parties have completed RAB, Aircore, RC and Diamond Drilling, geological interpretation, soil sampling, exploration and resource drilling, geophysical surveys, data collation and modelling. At Rebecca significant recent resource drilling was conducted by Apollo in 2018-2021, and at Roe Breaker Resources NL has conducted all previous work.
Geology	<ul style="list-style-type: none"> Deposit type, geological setting and style of mineralisation. 	<ul style="list-style-type: none"> Rebecca is hosted by felsic gneissic rocks of granodiorite & diorite composition. Gold mineralisation occurs in broad lode/shear zones of disseminated to veinlet style pyrrhotite-dominant sulphides accompanied by increased shear fabrics and moderate silicification. Archean orogenic gold mineralisation near major faults. Gold at Bombora is associated with



Criteria	JORC Code explanation	Commentary
		<p>subsidiary faults of the Claypan Shear Zone and occurs preferentially in the Fe-rich part of a fractionated dolerite in an area of shallow (5m to 20m) transported cover. The dolerite is folded into a domal geometry between two major shear zones that converge and bend in the vicinity of the project. Mineralisation also occurs in other predominantly mafic rocks in the hanging wall at Bombora, and at the Crescent-Kopai and Claypan deposits. Mineralisation occurs as high-grade, stockwork, disseminated and quartz vein hosted within the dolerite.</p>
<p>Drill hole Information</p>	<ul style="list-style-type: none"> • A summary of all information material to the understanding of the exploration results including a tabulation of the following information for all Material drill holes: <ul style="list-style-type: none"> ○ easting and northing of the drill hole collar ○ elevation or RL (Reduced Level – elevation above sea level in metres) of the drill hole collar ○ dip and azimuth of the hole ○ down hole length and interception depth ○ hole length. • If the exclusion of this information is justified on the basis that the information is not Material and this exclusion does not detract from the understanding of the report, the Competent Person should clearly explain why this is the case. 	<ul style="list-style-type: none"> • All the drill holes reported in this report have the following parameters applied. All drill holes completed, including holes with no significant results (as defined in the Attachments) are reported in this announcement. • Easting and northing are given in MGA94 or MGA2020 coordinates as defined in the Attachments. • RL is AHD • Dip is the inclination of the hole from the horizontal. Azimuth is reported in magnetic degrees as the direction the hole is drilled. MGA94 and MGA2020 and magnetic degrees vary by <1degree in the project area. All reported azimuths are corrected for magnetic declinations. • Down hole length is the distance measured along the drill hole trace. Intersection length is the thickness of an anomalous gold intersection measured along the drill hole trace. • Hole length is the distance from the surface to the end of the hole measured along the drill hole trace. • No results currently available from the exploration drilling are excluded from this report. Gold grade intersections >0.4 g/t Au within 4m Aircore composites or >0.5 g/t Au within single metre RC samples (generally using a maximum of 2m of internal dilution but additional dilution where specifically indicated) are considered significant in the broader mineralised host rocks. Diamond core samples are generally cut along geological contacts or up to 1m maximum. • Gold grades greater than 0.5 g/t Au are highlighted where good continuity of higher-grade mineralisation is observed. A 0.1 g/t Au cut-off grade is used for reconnaissance exploration programmes.
<p>Data aggregation methods</p>	<ul style="list-style-type: none"> • In reporting Exploration Results, weighting averaging techniques, maximum and/or minimum grade truncations (e.g. cutting of high grades) and cut-off grades are usually Material and should be stated. • Where aggregate intercepts incorporate short lengths of high-grade results and longer lengths of low-grade results, the procedure used 	<ul style="list-style-type: none"> • The first gold assay result received from each sample reported by the laboratory is tabled in the list of significant assays. Subsequent repeat analyses when performed by the laboratory are checked against the original to ensure repeatability of the assay results. • Weighted average techniques are applied to determine the grade of the anomalous interval when geological intervals less than 1m have been sampled.

For personal use only



Criteria	JORC Code explanation	Commentary
	<p>for such aggregation should be stated and some typical examples of such aggregations should be shown in detail.</p> <ul style="list-style-type: none"> The assumptions used for any reporting of metal equivalent values should be clearly stated. 	<ul style="list-style-type: none"> Exploration drilling results are generally reported using a 0.5 g/t Au lower cut-off for RC and diamond or 0.1 g/t Au for Aircore drilling (as described above and reported in the Attachments) and may include up to 4m of internal dilution or more where specifically indicated. Significant resource development drill hole assays are reported greater than 0.5 or 8.0 g/t Au and are also reported separately. For example, the broader plus 1.0 g/t Au intersection of 6.5m @ 30.5 g/t Au contains a higher-grade zone running plus 8 g/t Au and is included as 4m @ 48.5 g/t Au. Where extremely high gold intersections are encountered as in this example, the highest-grade sample interval (e.g. 1.0m @ 150 g/t Au) is also reported. All assay results are reported to 3 significant figures in line with the analytical precision of the laboratory techniques employed. No metal equivalent reporting is used or applied. For REE reporting, a lower cut-off grade of 0.15% TREO is used with no internal dilution. No top-cuts are applied to TREO reporting.
Relationship between mineralisation widths and intercept lengths	<ul style="list-style-type: none"> These relationships are particularly important in the reporting of Exploration Results. If the geometry of the mineralisation with respect to the drill hole angle is known, its nature should be reported. If it is not known and only the down hole lengths are reported, there should be a clear statement to this effect (e.g. 'down hole length, true width not known'). 	<ul style="list-style-type: none"> The intersection length is measured down the length of the hole and is not usually the true width. When sufficient knowledge on the thickness of the intersection is known an estimate of the true thickness is provided in the Attachments. At Rebecca drilling is semi perpendicular to lodes and Rebecca & Duchess holes are often close to true width. At Duke drilling is orthogonal and more like the typical 60-70% width. The known geometry of the mineralisation with respect to drill holes reported for advanced projects is generally well constrained.
Diagrams	<ul style="list-style-type: none"> Appropriate maps and sections (with scales) and tabulations of intercepts should be included for any significant discovery being reported. These should include, but not be limited to a plan view of drill hole collar locations and appropriate sectional views. 	<ul style="list-style-type: none"> Detailed drill hole plans and sectional views of advanced prospects at Rebecca and Roe are provided or have been provided previously. Long section and cross-sectional views (orthogonal to the plunging shoots) are considered the best 2-D representation of the known spatial extent of the mineralisation.
Balanced reporting	<ul style="list-style-type: none"> Where comprehensive reporting of all Exploration Results is not practicable, representative reporting of both low and high grades and/or widths should be practiced to avoid misleading reporting of Exploration Results. 	<ul style="list-style-type: none"> This report relates to resources and reserves based on existing drillhole datasets. No new exploration results are reported. All previous RMS significant new drilling results have been previously reported. Generally, all holes are reported.
Other substantive exploration data	<ul style="list-style-type: none"> Other exploration data, if meaningful and material, should be reported including (but not limited to): geological observations; geophysical survey results; geochemical survey results; bulk samples – size and method of treatment; metallurgical test results; bulk density, groundwater, geo-technical and rock characteristics; potential deleterious or contaminating substances. 	<ul style="list-style-type: none"> All deposits have had some degree of additional sampling or testwork in regard to geotechnical investigation, geochemical characterisation, metallurgical testwork and density measurement, usually on specific selected diamond core holes. Other exploration data is useful in understanding geology and mineralisation types but is generally not material to resource estimation.



Criteria	JORC Code explanation	Commentary
Further work	<ul style="list-style-type: none"> The nature and scale of planned further work (e.g. tests for lateral extensions or depth extensions or large-scale step-out drilling). Diagrams clearly highlighting the areas of possible extensions, including the main geological interpretations and future drilling areas, provided this information is not commercially sensitive. 	<ul style="list-style-type: none"> Future exploration is dependent on specific circumstances at individual prospects but may include infill and step out RC and diamond drilling were justified to define the full extent of the mineralisation discovered to date.

Section 3 Estimation and Reporting of Mineral Resources

Criteria	JORC Code explanation	Commentary
Database integrity	<ul style="list-style-type: none"> Measures taken to ensure that data has not been corrupted by, for example, transcription or keying errors, between its initial collection and its use for Mineral Resource estimation purposes. Data validation procedures used. 	<ul style="list-style-type: none"> Recent Ramelius drilling employs an SQL central database using Datashed information management software. Data collection uses Field Marshall software with fixed templates and lookup tables for collecting field data electronically. Several validation checks occur upon data upload to the main database. Datasets were merged and show good agreement. Data collected by previous owners (Breaker and Apollo) employed similar techniques.
Site visits	<ul style="list-style-type: none"> Comment on any site visits undertaken by the Competent Person and the outcome of those visits. If no site visits have been undertaken indicate why this is the case. 	<ul style="list-style-type: none"> The Competent Person is a full-time employee of Ramelius Resources and has made multiple site visits
Geological interpretation	<ul style="list-style-type: none"> Confidence in (or conversely, the uncertainty of) the geological interpretation of the mineral deposit. Nature of the data used and of any assumptions made. The effect, if any, of alternative interpretations on Mineral Resource estimation. The use of geology in guiding and controlling Mineral Resource estimation. The factors affecting continuity both of grade and geology. 	<ul style="list-style-type: none"> Confidence in the geological interpretation is high. Data used includes drilling assays & logging from many of generations of drilling. No alternate interpretation required Geology forms a base component of the mineralisation interpretation. Rebecca mineralisation occurs as shear lodes hosted within a wide felsic gneissic unit. The lodes are defined by gold grade and generally have good correlation with logged sulphide content. Roe mineralisation occurs as high-grade, stockwork, disseminated and quartz vein hosted within dolerite which is crosscut by barren lamprophyre dykes
Dimensions	<ul style="list-style-type: none"> The extent and variability of the Mineral Resource expressed as length (along strike or otherwise), plan width, and depth below surface to the upper and lower limits of the Mineral Resource. 	<ul style="list-style-type: none"> Rebecca: Rebecca consists of multiple stacked lodes which collectively strike for approximately 1.7km and up to 400m down dip. Individual lodes are 10-30m thick. Duchess is similar but smaller with 850m strike & 5-30m wide. Duke strikes for 350m, is between 12m to 20m wide and 350m in depth. Bombora: Extends 4,525m along strike, has horizontal width up to 680m, and vertical extent of 722m. Mineralisation starts at 5m below surface to ~825m below surface. Width of mineralised zones ranges from 2 to 15m for steep



Criteria	JORC Code explanation	Commentary
		<p>lodes, up to ~150m for flat lodes, and 1 to 10m for west dipping lodes.</p> <ul style="list-style-type: none"> Claypan: Extends ~700m along strike, has horizontal width up to ~600m, and vertical extent of 100m. Mineralisation starts at 20m below surface to ~120m below surface. Width of mineralisation from 2 to 15m. Kopai-Crescent: Extends 2,100m along strike, has horizontal width up to 1,400m, and vertical extent of 160m. Mineralisation starts at 10m below surface to 160m below surface. Width of mineralised zones from 15 to 155m (east-west direction).
<p>Estimation and modelling techniques</p>	<ul style="list-style-type: none"> The nature and appropriateness of the estimation technique(s) applied and key assumptions, including treatment of extreme grade values, domaining, interpolation parameters and maximum distance of extrapolation from data points. If a computer assisted estimation method was chosen include a description of computer software and parameters used. The availability of check estimates, previous estimates and/or mine production records and whether the Mineral Resource estimate takes appropriate account of such data. The assumptions made regarding recovery of by-products. Estimation of deleterious elements or other non-grade variables of economic significance (e.g. sulphur for acid mine drainage characterisation). In the case of block model interpolation, the block size in relation to the average sample spacing and the search employed. Any assumptions behind modelling of selective mining units. Any assumptions about correlation between variables. Description of how the geological interpretation was used to control the resource estimates. Discussion of basis for using or not using grade cutting or capping. The process of validation, the checking process used, the comparison of model data to drill hole data, and use of reconciliation data if available. 	<ul style="list-style-type: none"> Rebecca: 3D mineralisation wireframes interpreted in Micromine. Sectional lode shapes interpreted based on 0.3-0.5g/t cutoff. Hard bounded grade estimation by Ordinary Kriged method using 1m composited topcut assay data to parent cells only. Anisotropic search ellipse based on interpretation of continuity. Models were validated visually against assay data. Roe: 3D mineralisation wireframes interpreted in Leapfrog. Lode domains interpreted based on a 0.1g/t Au cutoff above 100mRL and 0.3g/t Au cutoff below 100mRL. Grade estimation by Ordinary Kriging using 1m composited topcut assay data. Dynamic anisotropy applied to search neighbourhoods and three search passes controlled by variography were applied. Inverse distance squared method was used where a reliable variogram could not be produced. 100% of blocks were estimated in the first three passes. Check estimates were conducted using ID2 methods. Several previous estimates were available and all relevant previous estimates were considered. Both Rebecca and Roe are considered maiden resources and no mine production data exists for consideration. Only gold is estimated. No by-products recovered. No deleterious elements present Rebecca: Block size 5mE x 10mN x 5mRL with limited subcells to 50%. Parent cell estimation only. Anisotropic search - maximum range 75m Roe: Block size typically 10mE x 10mN x 5mRL with subcells to minimum of 1mE x 1mN x 0.5mRL. Anisotropic search - maximum range 100m Parent block size is generally assumed to match SMU size. Grades assumed to correlate along mineralised trends/wireframes and/or estimated using anisotropic searches matching correlation directions Domains are geostatistically analysed and assigned appropriate search directions, top-cuts and estimation parameters. Variography and the

For personal use only



Criteria	JORC Code explanation	Commentary
		<p>observed geological strike and dip of ore mineralisation is used to generate search criteria.</p> <ul style="list-style-type: none"> • Samples were composited within ore domains to 1m lengths. • Top cuts were applied to domains after review of grade population characteristics. Top cuts used in all estimates were between the 97.5 and 99.5 percentile range. • Validation includes visual comparison against drillhole grades, swath plots, and comparison against previous models.
Moisture	<ul style="list-style-type: none"> • Whether the tonnages are estimated on a dry basis or with natural moisture, and the method of determination of the moisture content. 	<ul style="list-style-type: none"> • Tonnages are estimated on a dry basis
Cut-off parameters	<ul style="list-style-type: none"> • The basis of the adopted cut-off grade(s) or quality parameters applied. 	<p>The cut-offs used are appropriate for the bulked low-grade mining methods used at Ramelius. Reporting cut-off grades are adopted to be around operating ore cutoff grades, typically 0.5 - 1.0 g/t, with variances for deposit mineralisation tenor, location and mining method. For most deposits interpretation cutoff is typically in the 0.3 to 0.7g/t range. These cutoffs encapsulate the mineralisation effectively and typically discriminate economic material from waste. Considerations of geology, nugget effect, width and shape continuity mean significant sub-grade material is often incorporated to create realistically mineable resources.</p>
Mining factors or assumptions	<ul style="list-style-type: none"> • Assumptions made regarding possible mining methods, minimum mining dimensions and internal (or, if applicable, external) mining dilution. It is always necessary as part of the process of determining reasonable prospects for eventual economic extraction to consider potential mining methods, but the assumptions made regarding mining methods and parameters when estimating Mineral Resources may not always be rigorous. Where this is the case, this should be reported with an explanation of the basis of the mining assumptions made. 	<ul style="list-style-type: none"> • Resources are reported on the assumption of mining by conventional open pit or bulked UG mining methods. Parent block size and estimation methodology were selected to generate a model appropriate for open pit mining on 2.5m flitches. • Roe (Bombora) underground resources were considered using Mineable Shape Optimiser in Deswick software with a cutoff of 1.5g/t, \$3,250 gold price, 2m to 4m minimum width depending on steep or flat lode orientation, 95% recovery plus 5% additional dilution on 10mH x 10mL blocks.
Metallurgical factors or assumptions	<ul style="list-style-type: none"> • The basis for assumptions or predictions regarding metallurgical amenability. It is always necessary as part of the process of determining reasonable prospects for eventual economic extraction to consider potential metallurgical methods, but the assumptions regarding metallurgical treatment processes and parameters made when reporting Mineral Resources may not always be rigorous. Where this is the case, this should be reported with an explanation of the basis of the 	<ul style="list-style-type: none"> • Rebecca and Roe testwork to date shows the deposit is free-milling for all deposits. Rebecca and Roe testwork shows good recoveries are achievable between 92-95%.



Criteria	JORC Code explanation	Commentary
	metallurgical assumptions made.	
Environmental factors or assumptions	<ul style="list-style-type: none"> Assumptions made regarding possible waste and process residue disposal options. It is always necessary as part of the process of determining reasonable prospects for eventual economic extraction to consider the potential environmental impacts of the mining and processing operation. While at this stage the determination of potential environmental impacts, particularly for a greenfields project, may not always be well advanced, the status of early consideration of these potential environmental impacts should be reported. Where these aspects have not been considered this should be reported with an explanation of the environmental assumptions made. 	<ul style="list-style-type: none"> Testwork shows no significant issues with waste rock or tailings. Ore treatment and tailings generation will occur at the Rebecca site. Rebecca and Roe are at an early stage and various approvals are required.
Bulk density	<ul style="list-style-type: none"> Whether assumed or determined. If assumed, the basis for the assumptions. If determined, the method used, whether wet or dry, the frequency of the measurements, the nature, size and representativeness of the samples. The bulk density for bulk material must have been measured by methods that adequately account for void spaces (vugs, porosity, etc.), moisture and differences between rock and alteration zones within the deposit. Discuss assumptions for bulk density estimates used in the evaluation process of the different materials. 	<ul style="list-style-type: none"> Density values are adopted from recent testwork on diamond drill holes completed at Rebecca and Roe. Density measurements were completed on the diamond core holes using the weight in air/weight in water method. They have been assigned by geological and weathering domains. Any previously assumed bulk density estimates were compared to measured material from the region. All resources have dry densities assigned by geologically interpreted weathering horizon, plus rock type where appropriate. Downhole geophysical studies were applied to oxides and transported cover where measurements were available. It is assumed the deposit densities can be represented by the average values determined or estimated by rock type and oxidation type.
Classification	<ul style="list-style-type: none"> The basis for the classification of the Mineral Resources into varying confidence categories. Whether appropriate account has been taken of all relevant factors (i.e. relative confidence in tonnage/grade estimations, reliability of input data, confidence in continuity of geology and metal values, quality, quantity and distribution of the data). Whether the result appropriately reflects the Competent Person's view of the deposit. 	<ul style="list-style-type: none"> The resource has been classified as Measured, Indicated, or Inferred categories based on geological and grade continuity and drillhole spacing and generation. Mineable Stope Optimiser and/or grade shell optimisation using current and future gold price assumptions were also considered in the classifications. The resource classification accounts for all relevant factors. The classification reflects the Competent Person's view.
Audits or reviews	<ul style="list-style-type: none"> The results of any audits or reviews of Mineral Resource estimates. 	<ul style="list-style-type: none"> Rebecca Mineral Resource Estimate was externally reviewed by Cube in April 2023. Roe Mineral Resource Estimate was externally reviewed and originally estimated by Snowden-Optiro in 2021.



Criteria	JORC Code explanation	Commentary
Discussion of relative accuracy/confidence	<ul style="list-style-type: none"> Where appropriate a statement of the relative accuracy and confidence level in the Mineral Resource estimate using an approach or procedure deemed appropriate by the Competent Person. For example, the application of statistical or geostatistical procedures to quantify the relative accuracy of the resource within stated confidence limits, or, if such an approach is not deemed appropriate, a qualitative discussion of the factors that could affect the relative accuracy and confidence of the estimate. The statement should specify whether it relates to global or local estimates, and, if local, state the relevant tonnages, which should be relevant to technical and economic evaluation. Documentation should include assumptions made and the procedures used. These statements of relative accuracy and confidence of the estimate should be compared with production data, where available. 	<ul style="list-style-type: none"> No fatal flaws or high-risk issues were identified in either Mineral Resource Estimate. The accuracy and confidence in the Mineral Resource Estimate is high given the deposit style, quality and density of drilling and sampling, both historic and new. Both deposits have a number of previous resource estimates for comparison, including those done by independent consultants. All resources are global estimates. No production data exists for a comparison.

Section 4 - Estimation and Reporting of Ore Reserves

Criteria	JORC Code explanation	Commentary
Mineral Resource estimate for conversion to Ore Reserves	<ul style="list-style-type: none"> Description of the Mineral Resource estimate used as a basis for the conversion to an Ore Reserve. Clear statement as to whether the Mineral Resources are reported additional to, or inclusive of, the Ore Reserves. 	<ul style="list-style-type: none"> Mineral Resource models described in Section 3 were used for mining evaluation, design and reporting. Mineral Resources are reported inclusive of Ore Reserves.
Site visits	<ul style="list-style-type: none"> Comment on any site visits undertaken by the Competent Person and the outcome of those visits. If no site visits have been undertaken indicate why this is the case. 	<ul style="list-style-type: none"> The Competent Person has visited the site.
Study Status	<ul style="list-style-type: none"> The type and level of study undertaken to enable Mineral Resources to be converted to Ore Reserves The Code requires that a study to at least Pre- Feasibility Study level has been undertaken to convert Mineral Resources to Ore Reserves. Such studies will have been carried out and will have determined a mine plan that is technically achievable and economically viable, and that material Modifying Factors have been considered. The effect, if any, of alternative interpretations on Mineral 	<ul style="list-style-type: none"> A pre-feasibility study has been carried out appropriate to the deposit type, mining method and scale. The study was carried out internally and externally using consultants where appropriate.



Criteria	JORC Code explanation	Commentary
	<ul style="list-style-type: none"> Resource estimation. 	
Cut-off parameters	<ul style="list-style-type: none"> The basis of the cut-off grade(s) or quality parameters applied. 	<ul style="list-style-type: none"> A 0.4 to 0.5g/t cutoff grade has been applied, based upon haulage, treatment and site administration overheads.
Mining factors or assumptions	<ul style="list-style-type: none"> The method and assumptions used as reported in the Pre-Feasibility or Feasibility Study to convert the Mineral Resource to an Ore Reserve (i.e. either by application of appropriate factors by optimisation or by preliminary or detailed design). The choice, nature and appropriateness of the selected mining method(s) and other mining parameters including associated design issues such as pre-strip, access, etc. The assumptions made regarding geotechnical parameters (eg pit slopes, stope sizes, etc), grade control and pre-production drilling. The major assumptions made and Mineral Resource model used for pit and stope optimisation (if appropriate). The mining dilution factors used. The mining recovery factors used. Any minimum mining widths used. The manner in which Inferred Mineral Resources are utilised in mining studies and the sensitivity of the outcome to their inclusion. The infrastructure requirements of the selected mining methods. 	<ul style="list-style-type: none"> The Rebecca, Duchess and Duke block models were regularized to 5m x 5m x 2.5m. The Bombora block model was regularized to 2.5m x 2.5m x 2.5m. A 10% dilution allowance has been made in Bombora pits and 5% for Rebecca, Duchess and Duke. 2% Ore Loss has been applied to all pits. Ore Reserves do not include Inferred Resources. The DFS includes 2koz of open pit production from Inferred Mineral Resources and the DFS outcomes are not dependent upon Inferred Mineral Resources. The mining program is contingent upon key infrastructure being installed such as process plant, accommodation camps, power supply, roads etc.
Metallurgical factors or assumptions	<ul style="list-style-type: none"> The metallurgical process proposed and the appropriateness of that process to the style of mineralisation Whether the metallurgical process is well- tested technology or novel in nature. The nature, amount and representativeness of metallurgical test work undertaken, the nature of the metallurgical domaining applied and the corresponding metallurgical recovery factors applied. Any assumptions or allowances made for deleterious elements. The existence of any bulk sample or pilot scale test work and the degree to which such samples are considered representative of the orebody as a whole. For minerals that are defined by a specification, has the ore reserve estimation been based on the appropriate mineralogy to meet the specifications? 	<ul style="list-style-type: none"> Processing will be through conventional milling, gravity gold recovery and CIL/CIP gold leaching. The proposed process is not new technology and has been applied to a variety of similar ores in the district. Leach and comminution testwork has been undertaken on all ore sources. Rebecca ores are sensitive to grind size but no deleterious elements have been identified. Recovery assumption is 93.3% for Rebecca, Duchess and Duke and 92% for fresh Bombora and 95% for oxidised Bombora sources.



Criteria	JORC Code explanation	Commentary
Environmental	The status of studies of potential environmental impacts of the mining and processing operation. Details of waste rock characterisation and the consideration of potential sites, status of design options considered and, where applicable, the status of approvals for process residue storage and waste dumps should be reported.	<ul style="list-style-type: none"> • Baseline studies are largely complete including waste characterisation. • Licenses and permits required and yet to be obtained include: EPA Part V for Rebecca, EPA Part IV for Roe, Mining Proposals under Mining Act, License to take water under RIWI Act. These approvals are contingent upon application and grant of additional tenure.
Infrastructure	<ul style="list-style-type: none"> • The existence of appropriate infrastructure: availability of land for plant development, power, water, transportation (particularly for bulk commodities), labour, accommodation; or the ease with which the infrastructure can be provided or accessed. 	<ul style="list-style-type: none"> • The Kurnalpi-Pinjin Road (part of access to site) is already part of the main supply route for other existing operations. • Infrastructure required includes administration offices, ablutions, accommodation camp including water supply and treatment plant, airstrip, mining and haulage workshops, fuel tanks, generators for surface infrastructure and mining requirements, surface explosives magazine, dewatering and water transfer equipment and pipelines, surface water storage dam, access road and ore haulage road.
Costs	<ul style="list-style-type: none"> • The derivation of, or assumptions made, regarding projected capital costs in the study. • The methodology used to estimate operating costs. • Allowances made for the content of deleterious elements. • The derivation of assumptions made of metal or commodity price(s), for the principal minerals and co- products. • The source of exchange rates used in the 	<ul style="list-style-type: none"> • Capital costs are based on a combination of project specific quotes and recent capital expenditure for similar plant and equipment and infrastructure at other Ramelius Operations. • Mining contract rates reflect a recent proposal from an experienced mining contractor. • Operating costs are based on bottom-up estimates. • No deleterious elements present. • Cost models use Australian dollars. • A diesel fuel cost of \$1.00/L (excluding fuel excise and GST)
	<ul style="list-style-type: none"> • study. • Derivation of transportation charges. • The basis for forecasting or source of treatment and refining charges, penalties for failure to meet specification, etc. • The allowances made for royalties payable, • both Government and private. 	<ul style="list-style-type: none"> • No penalties or specifications are applicable. • State royalty of 2.5% applied • Third party royalty of 1.5% NSR has been applied to the main Rebecca mining tenement. • Additional allowances have been made to reflect likely applicable payments to stakeholders once negotiations are complete.
Revenue Factors	<ul style="list-style-type: none"> • The derivation of, or assumptions made regarding revenue factors including head grade, metal or commodity price(s) exchange rates, transportation and treatment charges, penalties, net smelter returns, etc. • The derivation of assumptions made of metal or commodity price(s), for the principal • metals, minerals and co-products. 	<ul style="list-style-type: none"> • Gold price of A\$3,500/oz was used for financial model. • Revenue from recovery of other metals was not considered in the Pre-Feasibility Study.
Market Assessment	<ul style="list-style-type: none"> • The demand, supply and stock situation for the particular commodity, consumption trends and factors likely to affect supply and demand into the future. 	<ul style="list-style-type: none"> • Doré is sold direct to the Perth Mint at spot price. • Market window unlikely to change. • A flat gold price assumption of \$3,500/oz is conservative relative to current spot gold price.



Criteria	JORC Code explanation	Commentary
	<ul style="list-style-type: none"> A customer and competitor analysis along with the identification of likely market windows for the product. Price and volume forecasts and the basis for these forecasts. For industrial minerals the customer specification, testing and acceptance requirements prior to a supply contract. 	<ul style="list-style-type: none"> Not an industrial mineral.
Classification	<ul style="list-style-type: none"> The basis for the classification of the Mineral Resources into varying confidence categories. Whether appropriate account has been taken of all relevant factors (i.e. relative confidence in tonnage/grade estimations, reliability of input data, confidence in continuity of geology and metal values, quality, quantity and distribution of the data). Whether the result appropriately reflects the Competent Person's view of the deposit. 	<ul style="list-style-type: none"> The resource has been classified as Measured, Indicated or Inferred categories based on geological and grade continuity and drillhole spacing and generation. The resource classification accounts for all relevant factors The classification reflects the Competent Person's view.
Economic	<ul style="list-style-type: none"> The inputs to the economic analysis to produce the net present value (NPV) in the study, the source and confidence of these economic inputs including estimated inflation, discount rate, etc. NPV ranges and sensitivity to variations in the significant assumptions and inputs. 	<ul style="list-style-type: none"> NPV of 5% used. Sensitivities were run on gold price, mining costs and mill recovery.
Social	<ul style="list-style-type: none"> The status of agreements with key stakeholders and matters leading to social licence to operate. 	<ul style="list-style-type: none"> Stakeholders have been engaged but final agreements are yet to be executed with pastoral and traditional owner Stakeholders.
Other	<p>To the extent relevant, the impact of the following on the project and/or on the estimation and classification of the Ore Reserves:</p> <ul style="list-style-type: none"> Any identified material naturally occurring risks. The status of material legal agreements and marketing arrangements. The status of governmental agreements and approvals critical to the viability of the project, such as mineral tenement status, and government and statutory approvals. There must be reasonable grounds to expect that all necessary Government approvals will be received within the timeframes anticipated in the Pre-Feasibility or Feasibility study. Highlight and discuss the materiality of any unresolved matter that is dependent on a third party on which extraction of the reserve is contingent. 	<ul style="list-style-type: none"> Flood risk at Rebecca is well understood and has been addressed with designed bunding and controls. The approvals pathway has been examined and no material flaws identified. The project relies on the grant of various tenements which in turn are dependent upon successful negotiations with stakeholders.



Criteria	JORC Code explanation	Commentary
Classification	<ul style="list-style-type: none"> The basis for the classification of the Ore Reserves into varying confidence categories. Whether the result appropriately reflects the Competent Person's view of the deposit. The proportion of Probable Ore Reserves that have been derived from Measured Mineral Resources (if any) 	<ul style="list-style-type: none"> Ore Reserves are classified according to Resource classification. They reflect the Competent Person's view. All Ore Reserves are Probable.
Audits or reviews	The results of any audits or reviews of Ore Reserve estimates.	<ul style="list-style-type: none"> No external audits carried out.
Discussion of relative accuracy / confidence	<ul style="list-style-type: none"> Where appropriate a statement of the relative accuracy and confidence level in the Ore Reserve estimate using an approach or procedure deemed appropriate by the Competent Person. For example, the application of statistical or geostatistical procedures to quantify the relative accuracy of the reserve within stated confidence limits, or, if such an approach is not deemed appropriate, a qualitative discussion of the factors which could affect the relative accuracy and confidence of the estimate. The statement should specify whether it relates to global or local estimates, and, if local, state the relevant tonnages, which should be relevant to technical and economic evaluation. Documentation should include assumptions made and the procedures used. Accuracy and confidence discussions should extend to specific discussions of any applied Modifying Factors that may have a material impact on Ore Reserve viability, or for which there are remaining areas of uncertainty at the current study stage. It is recognised that this may not be possible or appropriate in all circumstances. These statements of relative accuracy and confidence of the estimate should be compared with production data, where available. 	<ul style="list-style-type: none"> Confidence is in line with gold industry standards and the companies aim and track record on providing effective prediction of mining projects. No statistical quantification of confidence limits has been applied. The Reserve is most sensitive to gold price, mill grade and metallurgical recovery.